

LM2700

5-Unit Fairway Mower

Parts catalog

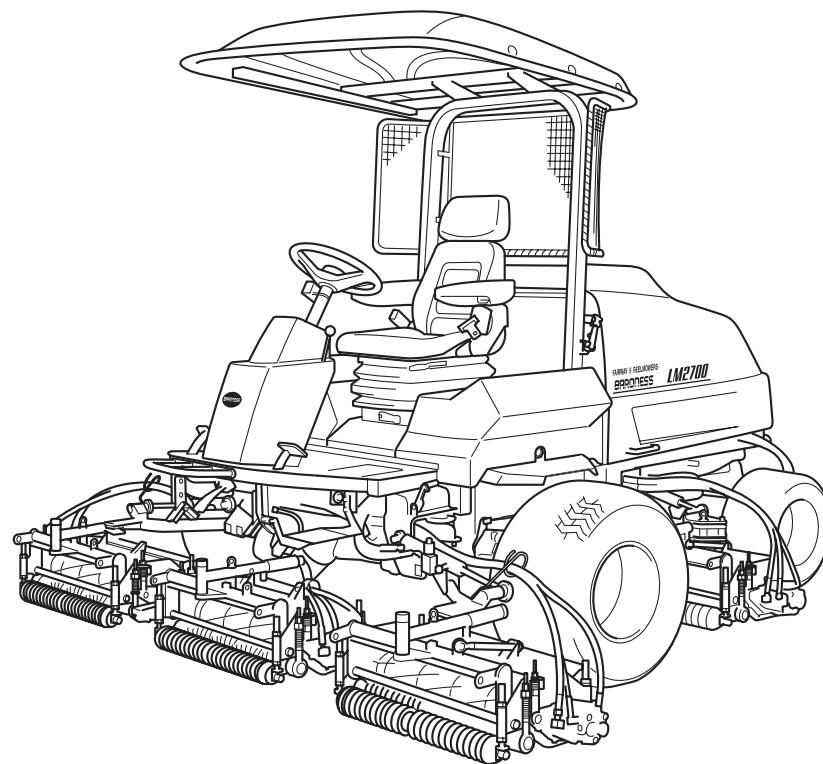

Serial No.11001-

BARONESS[®]
Quality on Demand

Ver.3.0

Greeting

Thank you for purchasing Baroness machine.

This machine has been shipped from the factory after comprehensive test runs and inspections. However, the optimum performance of the machine depends on how you use and maintain it, including routine inspections, adjustments, and fuel supplies before and after the operation.

We hope you will use the machine safely, and take advantage of its best performance.

Note

(For inquiry about this machine)

Since the type of machine may be changed sequentially, inform us of the type and the serial number.

The information described in this manual is subject to change without prior notice.

When replacing parts, be sure to use Baroness parts or parts designated by Kyo-eisha.

Note that the Baroness product warranty may not apply to defects caused by the use of parts from other companies.

(For ordering parts)

For prevention of delivery of wrong parts, be sure to inform us of the code number and the part name.

Example:	Code No.	Part Name	Qty
	LM2700-0620AD	STEP	1

Contents

PARTS CATALOGUE	2	143. Light section	71
101. 26inch Frame section A	3	144. 26inch Mower section A	73
102. 22inch Frame section A	7	145. 22inch Mower section A	75
103. Frame section B	11	146. 26inch Mower section B	77
104. Cover section	13	147. 22inch Mower section B	79
105. Front wheel section	15	148. 26inch Mower section C	81
106. Rear wheel section	17	149. 22inch Mower section C	83
107. Pedal section A	19	150. 26inch Roller Ass'y section A	85
108. Pedal section B	21	151. 22inch Roller Ass'y section A	87
109. Engine section A	23	152. 26inch Roller Ass'y section B	89
110. Engine section B	27	153. 22inch Roller Ass'y section B	91
111. 26inch Engine section C	31	154. 26inch Groomer Ass'y section A for mower unit #1,#3,#5 (Option).....	93
112. 22inch Engine section C	33	155. 22inch Groomer Ass'y section A for mower unit #1,#3,#5 (Option).....	95
113. Engine section D.....	35	156. 26inch Groomer Ass'y section B for mower unit #1,#3,#5 (Option).....	97
114. Hydraulic section A	37	157. 22inch Groomer Ass'y section B for mower unit #1,#3,#5 (Option).....	99
115. Hydraulic section B.....	41	158. 26inch Groomer Ass'y section A for mower unit #2,#4 (Option).....	101
116. Hydraulic section C	43	159. 22inch Groomer Ass'y section A for mower unit #2,#4 (Option).....	103
117. Hydraulic section D	45	160. 26inch Groomer Ass'y section B for mower unit #2,#4 (Option).....	105
118. Hydraulic section E.....	47	161. 22inch Groomer Ass'y section B for mower unit #2,#4 (Option).....	107
119. Hydraulic section F.....	49	162. 26inch CR brush section for mower unit #1,#3,#5 (Option) (accompanied by groomer).....	109
120. Hydraulic section G	51	163. 22inch CR brush section for mower unit #1,#3,#5 (Option) (accompanied by groomer).....	111
121. Hydraulic section H	55	164. 26inch CR brush section for mower unit #1,#3,#5 (Option)	113
122. 26inch Lift arm front section	57	165. 22inch CR brush section for mower unit #1,#3,#5 (Option)	115
123. 22inch Lift arm front section	59	166. 26inch CR brush section for mower unit #2,#4 (Option) (accompanied by groomer).....	117
124. 26inch Lift arm rear section	61	167. 22inch CR brush section for mower unit #2,#4 (Option) (accompanied by groomer).....	119
125. 22inch Lift arm rear section	63	168. 26inch CR brush section for mower unit #2,#4 (Option)	121
132. Accessory section.....	65	169. 22inch CR brush section for mower unit #2,#4 (Option)	123
133. 26inch Grass catcher section (Option)	67		
134. 22inch Grass catcher section (Option)	69		

101. 26inch Frame section A

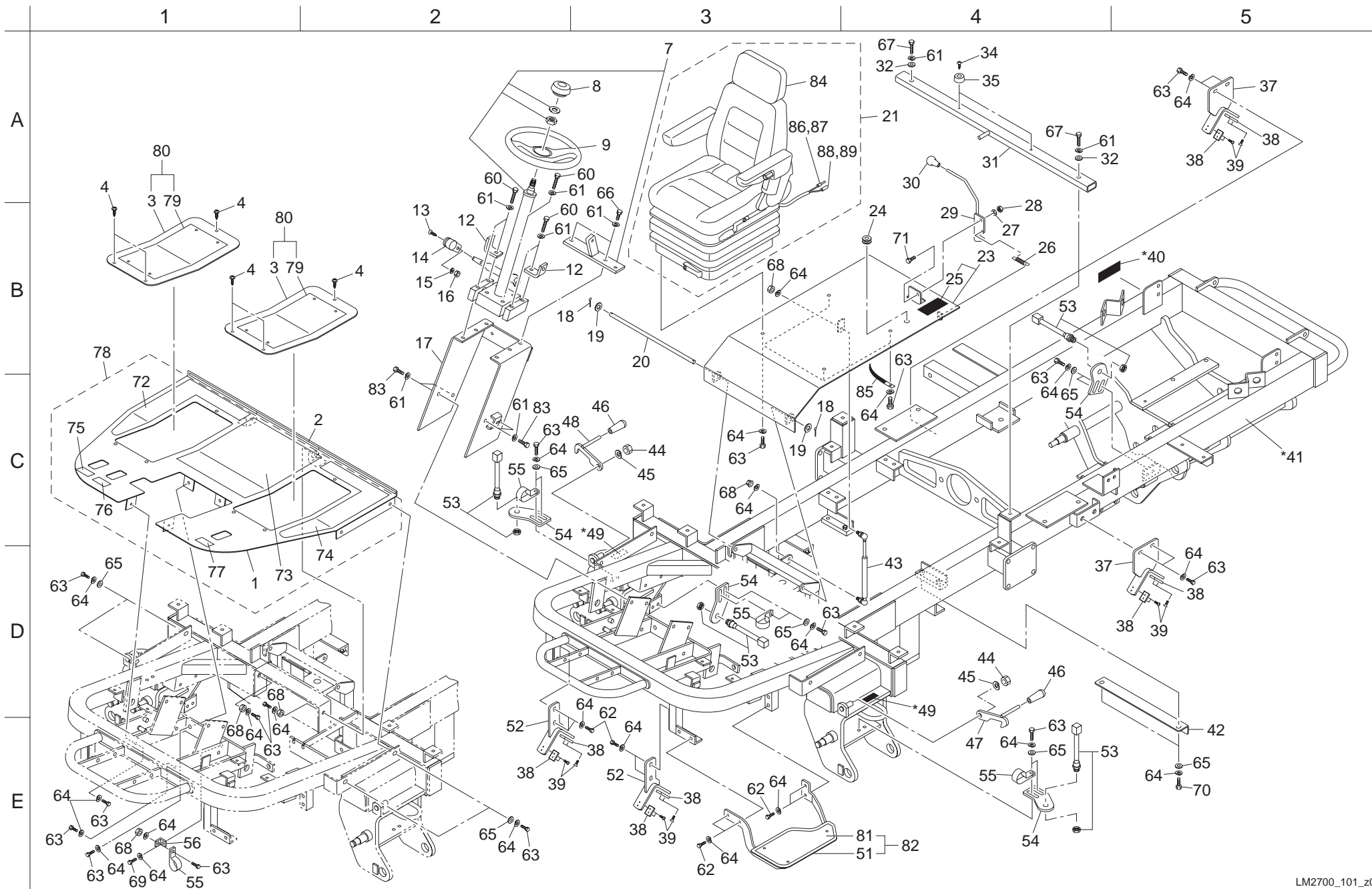

Cat No.	Code No.	Part name	Qty	Remark	SN of application	Cat No.	Code No.	Part name	Qty	Remark	SN of application
101-1	LM2700-0620BD	STEP	1			101-36					
101-2	K3198608900	TRIM, SEAL 6100-16A-890	1			101-37	LM2700-0614AD	STOPPER, MOWER	2		
101-3	LM2700-0621ZD	COVER, STEP	2			101-38	LM526A-0107Z0	STOPPER	8		
101-4	K0062080122	BOLT, BUTTON HEAD WITH HEX. HOLE M8-12	6			101-39	K0041060122	SCREW, + FLAT HEAD M6-12	16		
101-5						101-40	K4205001540	DECAL, CAUTION TO HOT PARTS	1		
101-6						101-41	LM2700-3601A0	FRAME COMP	1	*41 includes 40 and 49	
101-7	K1730000060	COLUMN, STEERING TILT TYPE	1			101-42	LM2700-0610ZD	STAY	1		
101-8	K1310000130	CAP, RUBBER	1			101-43	K3381000010	GAS-SPRING, C25	1		
101-9	K1710000100	STEERING, V02722-0101A	1			101-44	K0145140002	NUT, WITH F-RING, P1.5 M14	2		
101-10						101-45	K0210140002	SPRING, CONICAL DISC L M14	2		
101-11						101-46	K1300000110	GRIP, RUBBER YELLOW 9-22	2		
101-12	LM2700-0931ZD	MOUNT, FRONT COVER	2			101-47	LM526--0619AD	LEVER, #5 LOCK	1		
101-13	K0042050082	SCREW, + ROUND HEAD M5-8	1			101-48	LM526--0618AD	LEVER, #4 LOCK	1		
101-14	K1301000150	GRIP, PLASTIC THROTTLE LEVER	1			101-49	K4205000750	DECAL, CAUTION ARM LOCK	2		
101-15	K0200050002	WASHER, SPRING M5	1			101-50					
101-16	K0100050002	NUT, M5	1			101-51	LM2700-0619ZD	STEP	1		
101-17	LM2700-0602ZD	MOUNT, HANDLE	1			101-52	LM2700-0615ZD	STOPPER, MOWER	2		
101-18	K0300032252	PIN, COTTER M3.2-25	2			101-53	LM2700-0557Z0	SENSOR, PROXIMITY E2E-X5E	4		
101-19	K5000120002	WASHER, M12	2			101-54	LM2700-0625ZD	BRACKET, SWITCH	4		
101-20	LM2700-0609Z2	SHAFT, WITH HOLES M12-333	1			101-55	K4270050080	CLIP, HARNESS 50 M8	4		
101a-21	K1700000390	SEAT, DS85H190 COMP	1			101-56	LM2700-0571ZD	FITTING	1		
101-22						101-57					
101-23	LM2700-3602Z0	MOUNT COMP, SEAT	1			101-58					
101-24	K0900300240	GROMMET, W/SEALING C30SG24A	1			101-59					
101-25	K4205001580	DECAL, CAUTION TO INJURE	1			101-60	K0000100502	BOLT, M10-50	8		
101-26	K1030000098	SPRING, WITH U HOOK M1.6-12-66.8	1			101-61	K0200100002	WASHER, SPRING M10	16		
101-27	K5000100002	WASHER, M10	1			101-62	K0000080152	BOLT, M8-15	8		
101-28	K0144100002	NUT, M10 WITH F-RING	1			101-63	K0000080202	BOLT, M8-20	28		
101-29	LM2700-0607ZD	LEVER	1			101-64	K0200080002	WASHER, SPRING M8	39		
101-30	K1300000040	GRIP, RUBBER BLACK 9-35.5	1			101-65	K5000080002	WASHER, M8	14		
101-31	LM2700-0608BD	RECEIVER, SEAT	1			101-66	K0000100202	BOLT, M10-20	2		
101-32	K5073210352	WASHER, SPHC 3.2-10-35	2			101-67	K0000100402	BOLT, M10-40	2		
101-33						101-68	K0100080002	NUT, M8	5		
101-34	K0042050152	SCREW, + ROUND HEAD M5-15	2			101-69	K0000080252	BOLT, M8-25	1		
101-35	K4039000130	RUBBER, TK-3220	2			101-70	K0000080302	BOLT, M8-30	2		

101. 26inch Frame section A

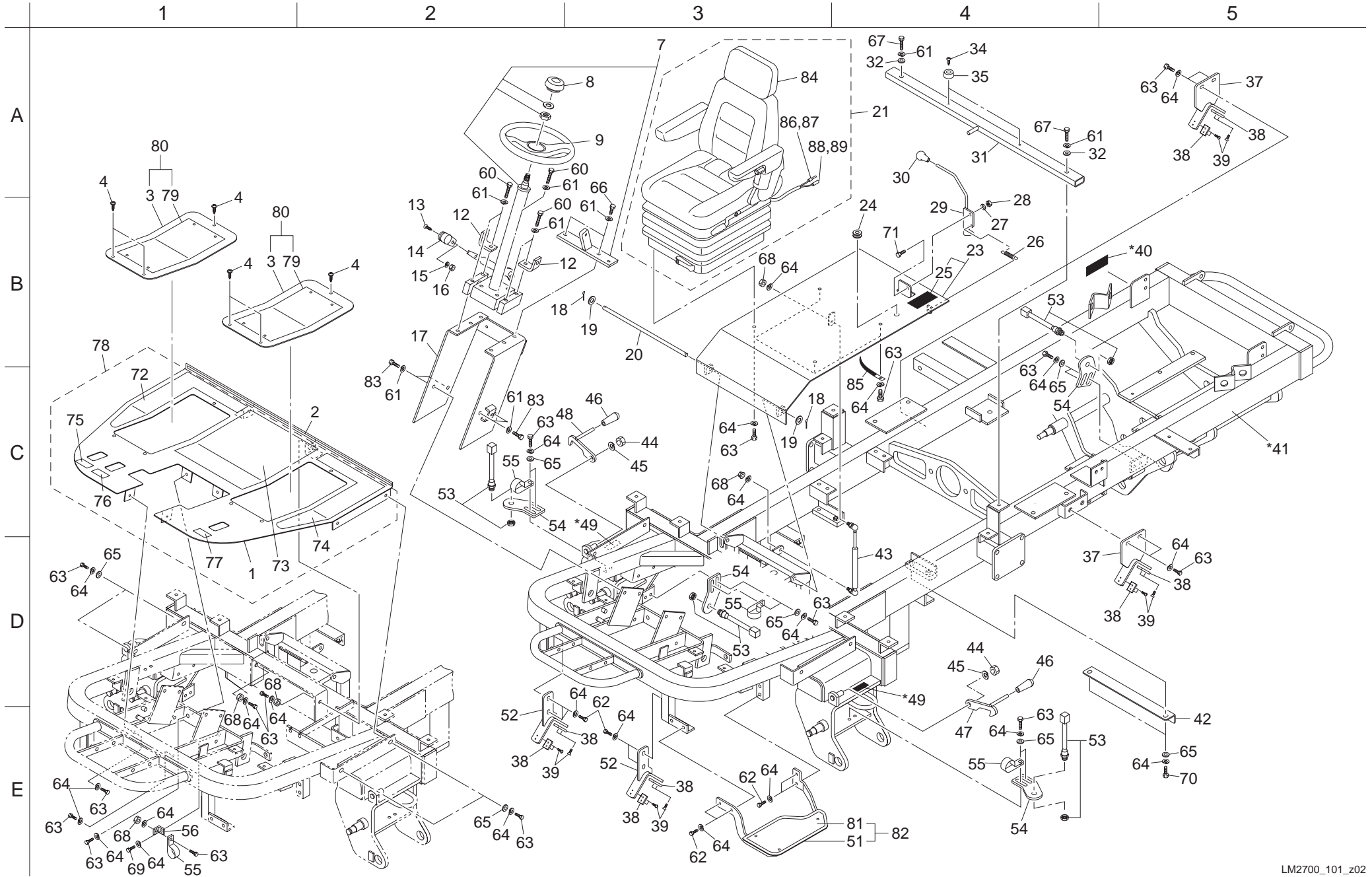

Cat No.	Code No.	Part name	Qty	Remark	SN of application	Cat No.	Code No.	Part name	Qty	Remark	SN of application
101-71	K0000100252	BOLT, M10-25	1								
101-72	K4400000070	SHEET, NONSLIP RIGHT	1								
101-73	K4400000100	SHEET, NONSLIP CENTER	1								
101-74	K4400000060	SHEET, NONSLIP LEFT	1								
101-75	K4203001440	DECAL, BACKWARD	1								
101-76	K4203001430	DECAL, FORWARD	1								
101-77	K4203001450	DECAL, BRAKE	1								
101-78	LM2700-0640Z0	STEP COMP	1								
101-79	K4400000080	SHEET, NONSLIP 346186	2								
101-80	LM2700-0641Z0	COVER COMP, STEP	2								
101-81	K4400000090	SHEET, STEP	1								
101-82	LM2700-0642Z0	STEP COMP	1								
101-83	K0000100152	BOLT, M10-15	4								
101a-84	K1700000250	SEAT, DS85H190	1								
101-85	K4281000020	CLAMP, HARNESS 8.5 80	1								
101-86	K3622000210	CONNECTOR, MALE CA104	1								
101-87	K3622000220	SLEEVE, INSULATED FOR CONNECTOR CA104	1								
101-88	K3622000230	CONNECTOR, FEMALE CB104	1								
101-89	K3622000240	SLEEVE, INSULATED FOR CONNECTOR CB104	1								

Cat No.	Code No.	Part name	Qty	Remark	SN of application	Cat No.	Code No.	Part name	Qty	Remark	SN of application
102-1	LM2700-0620BD	STEP	1			102-36					
102-2	K3198608900	TRIM, SEAL 6100-16A-890	1			102-37	LM2700-0614AD	STOPPER, MOWER	2		
102-3	LM2700-0621ZD	COVER, STEP	2			102-38	LM526A-0107Z0	STOPPER	6		
102-4	K0062080122	BOLT, BUTTON HEAD WITH HEX. HOLE M8-12	6			102-39	K0041060122	SCREW, + FLAT HEAD M6-12	12		
102-5						102-40	K4205001540	DECAL, CAUTION TO HOT PARTS	1		
102-6						102-41	LM2700-3601A0	FRAME COMP	1	*41 includes 40 and 49	
102-7	K1730000060	COLUMN, STEERING TILT TYPE	1			102-42	LM2700-0610ZD	STAY	1		
102-8	K1310000130	CAP, RUBBER	1			102-43	K3381000010	GAS-SPRING, C25	1		
102-9	K1710000100	STEERING, V02722-0101A	1			102-44	K0145140002	NUT, WITH F-RING, P1.5 M14	2		
102-10						102-45	K0210140002	SPRING, CONICAL DISC L M14	2		
102-11						102-46	K1300000110	GRIP, RUBBER YELLOW 9-22	2		
102-12	LM2700-0931ZD	MOUNT, FRONT COVER	2			102-47	LM526--0619AD	LEVER, #5 LOCK	1		
102-13	K0042050082	SCREW, + ROUND HEAD M5-8	1			102-48	LM526--0618AD	LEVER, #4 LOCK	1		
102-14	K1301000150	GRIP, PLASTIC THROTTLE LEVER	1			102-49	K4205001900	DECAL, CAUTION ARM LOCK	2		
102-15	K0200050002	WASHER, SPRING M5	1			102-50					
102-16	K0100050002	NUT, M5	1			102-51	LM2700-0619ZD	STEP	1		
102-17	LM2700-0602ZD	MOUNT, HANDLE	1			102-52	LM2700-0615ZD	STOPPER, MOWER	1		
102-18	K0300032252	PIN, COTTER M3.2-25	2			102-53	LM2700-0557Z0	SENSOR, PROXIMITY E2E-X5E	4		
102-19	K5000120002	WASHER, M12	2			102-54	LM2700-0625ZD	BRACKET, SWITCH	4		
102-20	LM2700-0609Z2	SHAFT, WITH HOLES M12-333	1			102-55	K4270050080	CLIP, HARNESS 50 M8	4		
102a-21	K1700000390	SEAT, DS85H190 COMP	1			102-56	LM2700-0571ZD	FITTING	1		
102-22						102-57	LM2700-2401ZD	STOPPER, MOWER	1		
102-23	LM2700-3602Z0	MOUNT COMP, SEAT	1			102-58	K0100100002	NUT, M10	1		
102-24	K0900300240	GROMMET, W/SEALING C30SG24A	1			102-59	K4049050000	STOPPER, RUBBER KI-50	1		
102-25	K4205001580	DECAL, CAUTION TO INJURE	1			102-60	K0000100502	BOLT, M10-50	8		
102-26	K1030000098	SPRING, WITH U HOOK M1.6-12-66.8	1			102-61	K0200100002	WASHER, SPRING M10	16		
102-27	K5000100002	WASHER, M10	1			102-62	K0000080152	BOLT, M8-15	8		
102-28	K0144100002	NUT, M10 WITH F-RING	1			102-63	K0000080202	BOLT, M8-20	28		
102-29	LM2700-0607ZD	LEVER	1			102-64	K0200080002	WASHER, SPRING M8	39		
102-30	K1300000040	GRIP, RUBBER BLACK 9-35.5	1			102-65	K5000080002	WASHER, M8	10		
102-31	LM2700-0608BD	RECEIVER, SEAT	1			102-66	K0000100202	BOLT, M10-20	2		
102-32	K5073210352	WASHER, SPHC 3.2-10-35	2			102-67	K0000100402	BOLT, M10-40	2		
102-33						102-68	K0100080002	NUT, M8	5		
102-34	K0042050152	SCREW, + ROUND HEAD M5-15	2			102-69	K0000080252	BOLT, M8-25	1		
102-35	K4039000130	RUBBER, TK-3220	2			102-70	K0000080302	BOLT, M8-30	2		

102. 22inch Frame section A

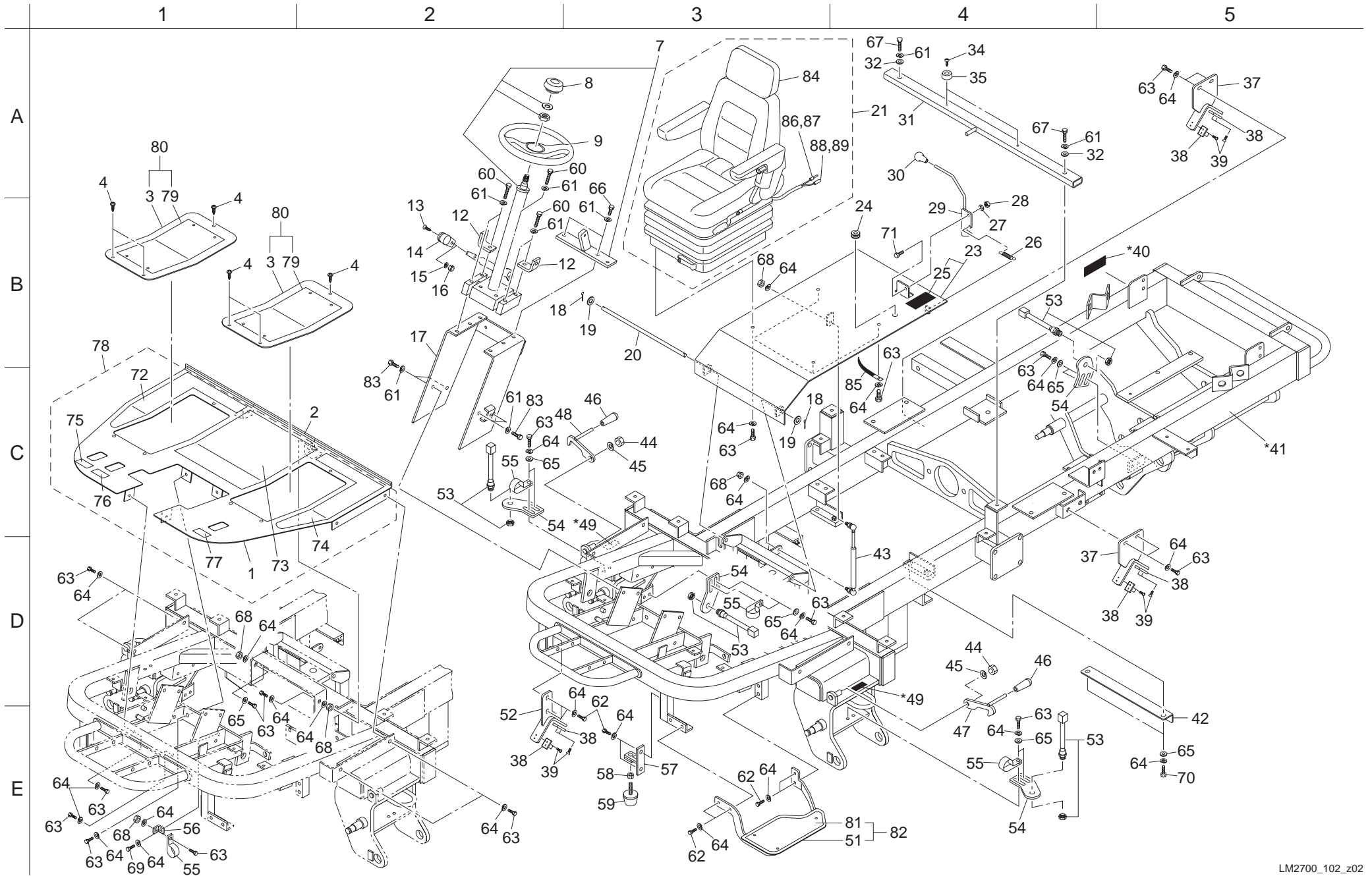

Cat No.	Code No.	Part name	Qty	Remark	SN of application	Cat No.	Code No.	Part name	Qty	Remark	SN of application
102-71	K0000100252	BOLT, M10-25	1								
102-72	K4400000070	SHEET, NONSLIP RIGHT	1								
102-73	K4400000100	SHEET, NONSLIP CENTER	1								
102-74	K4400000060	SHEET, NONSLIP LEFT	1								
102-75	K4203001440	DECAL, BACKWARD	1								
102-76	K4203001430	DECAL, FORWARD	1								
102-77	K4203001450	DECAL, BRAKE	1								
102-78	LM2700-0640Z0	STEP COMP	1								
102-79	K4400000080	SHEET, NONSLIP 346186	2								
102-80	LM2700-0641Z0	COVER COMP, STEP	2								
102-81	K4400000090	SHEET, STEP	1								
102-82	LM2700-0642Z0	STEP COMP	1								
102-83	K0000100152	BOLT, M10-15	4								
102a-84	K1700000250	SEAT, DS85H190	1								
102-85	K4281000020	CLAMP, HARNESS 8.5 80	1								
102-86	K3622000210	CONNECTOR, MALE CA104	1								
102-87	K3622000220	SLEEVE, INSULATED FOR CONNECTOR CA104	1								
102-88	K3622000230	CONNECTOR, FEMALE CB104	1								
102-89	K3622000240	SLEEVE, INSULATED FOR CONNECTOR CB104	1								

103. Frame section B

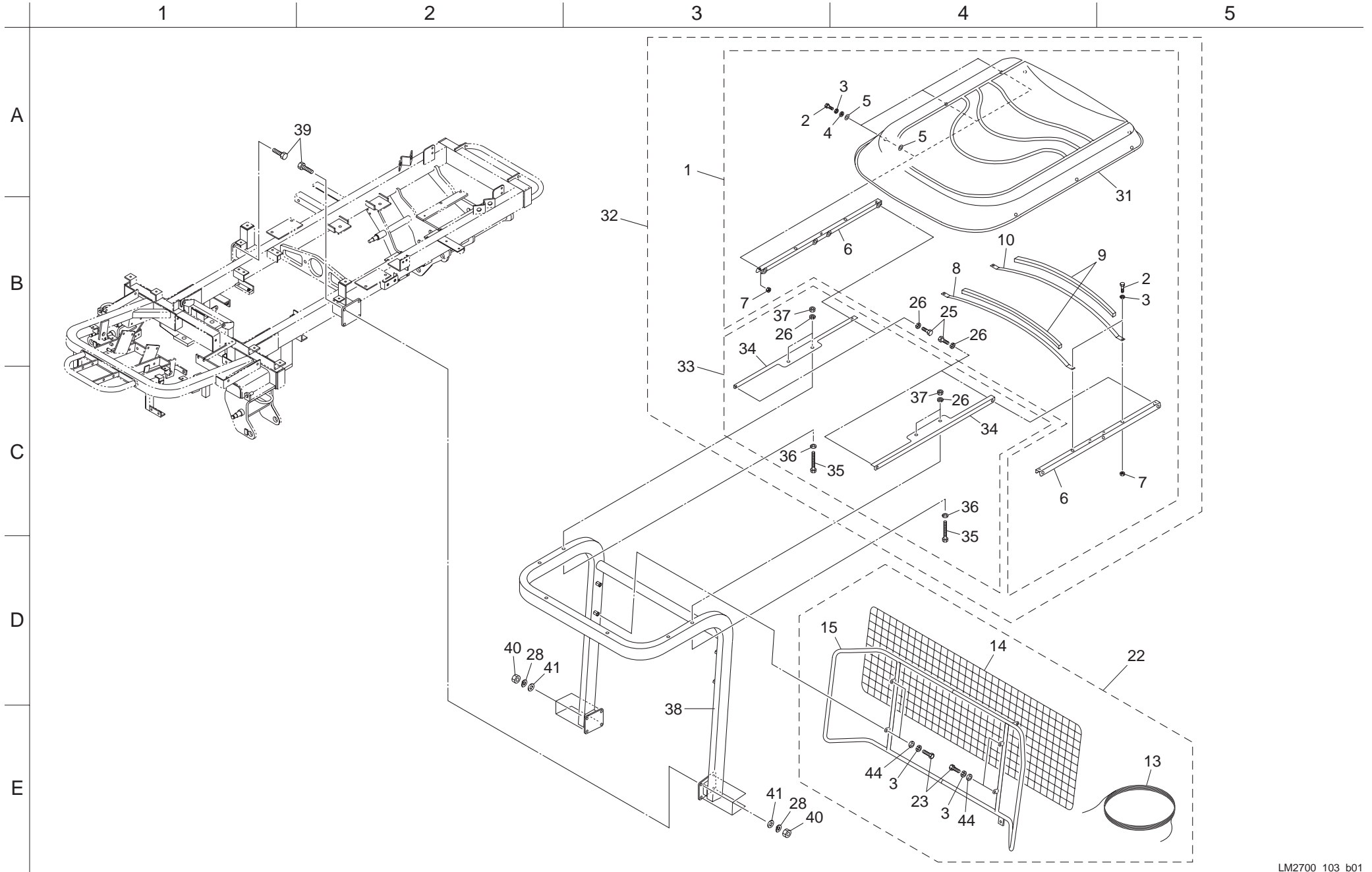

Cat No.	Code No.	Part name	Qty	Remark	SN of application	Cat No.	Code No.	Part name	Qty	Remark	SN of application
103-1	K9120000030	ROOF ASSY	1			103a-36	K5000100002	WASHER, M10	4		
103-2	K0000080202	BOLT, M8-20	10			103a-37	K0100100002	NUT, M10	4		
103-3	K0200080002	WASHER, SPRING M8	14			103b-38	LM2700-5102A0	ROPS (LM2700)	1		
103-4	K5012308352	WASHER, SPCC 2.3-8-35	6			103-39	K0024120401	BOLT, W HEX HOLE M12-40	8		#10356-
103-5	K1900000130	RUBBER, FOR ROOF	8			103-40	K0153121011	NUT, HT M12 SCM435H	8		#10356-
103-6	K190000011D	SUPPORT, HOOD	2			103-41	K5012312222	WASHER, SPCC 2.3-12-22	8		#10356-
103-7	K0100080002	NUT, M8	10			103-42					
103-8	K190000010D	ARCH, B	1			103-43					
103-9	K1900000120	SPONGE, URETHANE 20-20840	2			103-44	K5000080002	WASHER, M8	4		
103-10	K190000009D	ARCH, A	1								
103-11											
103a-12											
103-13	K4140000020	ROPE, 2-6700 S	2								
103-14	K4130000020	NET, PROTECTION 550*1375 S	1								
103-15	K789900109D	FRAME, FOR BALL PROOF NET	1								
103-16											
103a-17											
103-18											
103-19											
103-20											
103-21											
103a-22	K8990000040	NET ASSY, PROTECTION	1								
103-23	K0000080152	BOLT, M8-15	4								
103-24											
103-25	K0000100202	BOLT, M10-20	4								
103a-26	K0200100002	WASHER, SPRING M10	8								
103-27											
103a-28	K0200120002	WASHER, SPRING M12	8								
103a-29											
103-30											
103-31	K1900000080	ROOF	1								
103a-32	K9120000060	ROOF AND FRAME ASSY	1								
103a-33	K9120000050	BRACKET SET, FOR AWNING FRAME	1								
103a-34	K520500040D	PLATE, FOR FIXING ROOF	2								
103a-35	K0000101002	BOLT, M10-100	4								

104. Cover section

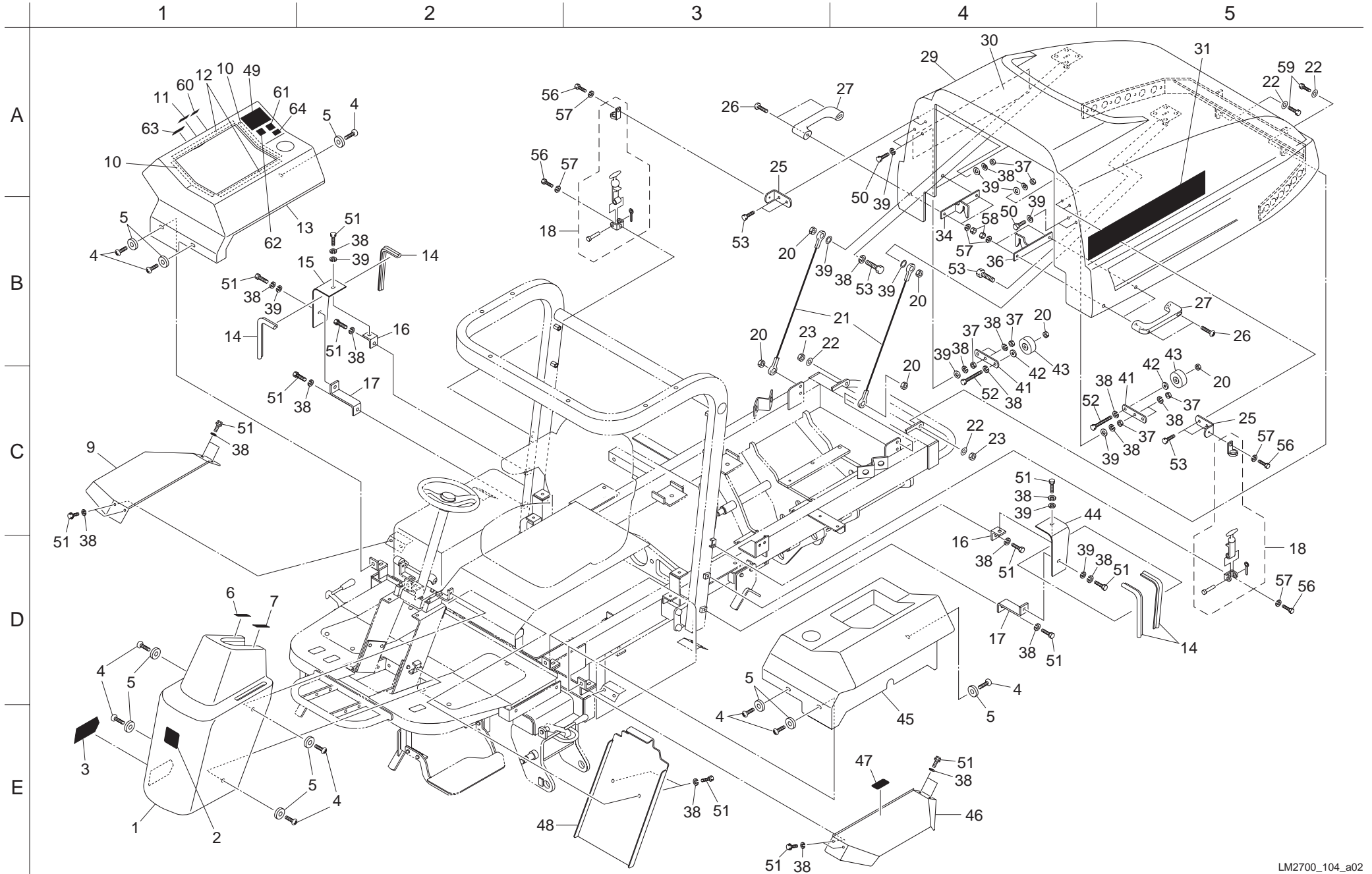

Cat No.	Code No.	Part name	Qty	Remark	SN of application	Cat No.	Code No.	Part name	Qty	Remark	SN of application
104-1	LM2700-0926A0	COVER, FRONT	1			104-36	LM2700-0934ZD	STOPPER, HOOD (L)	1		
104-2	K4201000590	STICKER, K	1			104-37	K0100080002	NUT, M8	12		
104-3	K4203001370	STICKER, VELOCITY	1			104-38	K0200080002	WASHER, SPRING M8	34		
104-4	K0056080200	SCREW, SUS + TRUSS M8-20	10			104-39	K5000080002	WASHER, M8	12		
104-5	K4031000070	RUBBER, VIBRATION PROOF 5-825	10			104-40					
104-6	K4203001350	STICKER, TILT STEERING	1			104-41	LM2700-0944ZD	BRACKET, ROLLER	2		
104-7	K4203001340	STICKER, PARKING BRAKE	1			104-42	K4031000210	RUBBER, ROUND WASHER	2		
104-8						104-43	K2141000020	WHEEL, CASTER NO.4H-P	2		
104-9	LM2700-0941ZD	COVER, TIRE (R)	1			104-44	LM2700-0948ZD	COVER, AUXILIARY (L)	1		
104-10	K4228000050	SPONGE, RUBBER 10-20-330	2			104-45	LM2700-0952Z0	COVER, SIDE (L)	1		
104-11	K4209001000	DECAL, DIESEL FUEL REFUELING HOLE	1			104-46	LM2700-0940ZD	COVER, TIRE (L)	1		
104-12	K4228000060	SPONGE, RUBBER 10-20-380	2			104-47	K4209000980	DECAL, HYDRAULIC OIL	1		
104a-13	LM2700-3905Z0	COVER COMP, SIDE (R)	1			104-48	LM2700-0951ZD	COVER, FRONT (REAR)	1		
104-14	K3198103500	TRIM, SEAL 6100-16C-350	4			104-49	K4205001840	STICKER, REEL START/STOP	1		
104-15	LM2700-0949ZD	COVER, AUXILIARY (R)	1			104-50	K0000080302	BOLT, M8-30	4		
104-16	LM2700-0946ZD	ANGLE, MOUNTING AUXILIARY COVER	2			104-51	K0000080152	BOLT, M8-15	18		
104-17	LM2700-0947ZD	BRACKET, AUXILIARY COVER	2			104-52	K0000080502	BOLT, M8-50	2		
104-18	K1520000030	HOOK ASSY, RUBBER	2			104-53	K0000080202	BOLT, M8-20	6		
104-19						104-54					
104-20	K0144080002	NUT, WITH F-RING, M8	6			104-55					
104-21	K1170092000	CABLE, 920	2			104-56	K0000060102	BOLT, M6-10	4		
104-22	K5000120002	WASHER, M12	4			104-57	K0200060002	WASHER, SPRING M6	8		
104-23	K0144120002	NUT, WITH F-RING, M12	2			104-58	K0100060002	NUT, M6	4		
104-24						104-59	K0000120302	BOLT, M12-30	2		
104-25	LM2700-0943ZD	MOUNT, RUBBER CATCH	2			104a-60	K4209001330	DECAL, DIESEL FUEL INDICATION	1		
104-26	K0042060252	SCREW, + ROUND HEAD M6-25	4			104a-61	K4205001330	DECAL, CAUTION TO NOISE	1		
104-27	K1301000160	GRIP, PLASTIC HANDLE	2			104a-62	K4209001290	DECAL, NOISE LEVEL LWA 103	1		
104-28						104-63	K4205001940	DECAL, CAUTION FIRE	1		
104-29	LM2700-0945B0	HOOD COMP	1			104-64	K4205001950	DECAL, CAUTION EXHAUST GAS	1		
104-30	LM2700-0956Z0	STICKER, BARONESS LM2700 (R)	1								
104-31	LM2700-0955Z0	STICKER, BARONESS LM2700 (L)	1								
104-32											
104-33											
104-34	LM2700-0935ZD	STOPPER, HOOD (R)	1								
104-35											

105. Front wheel section

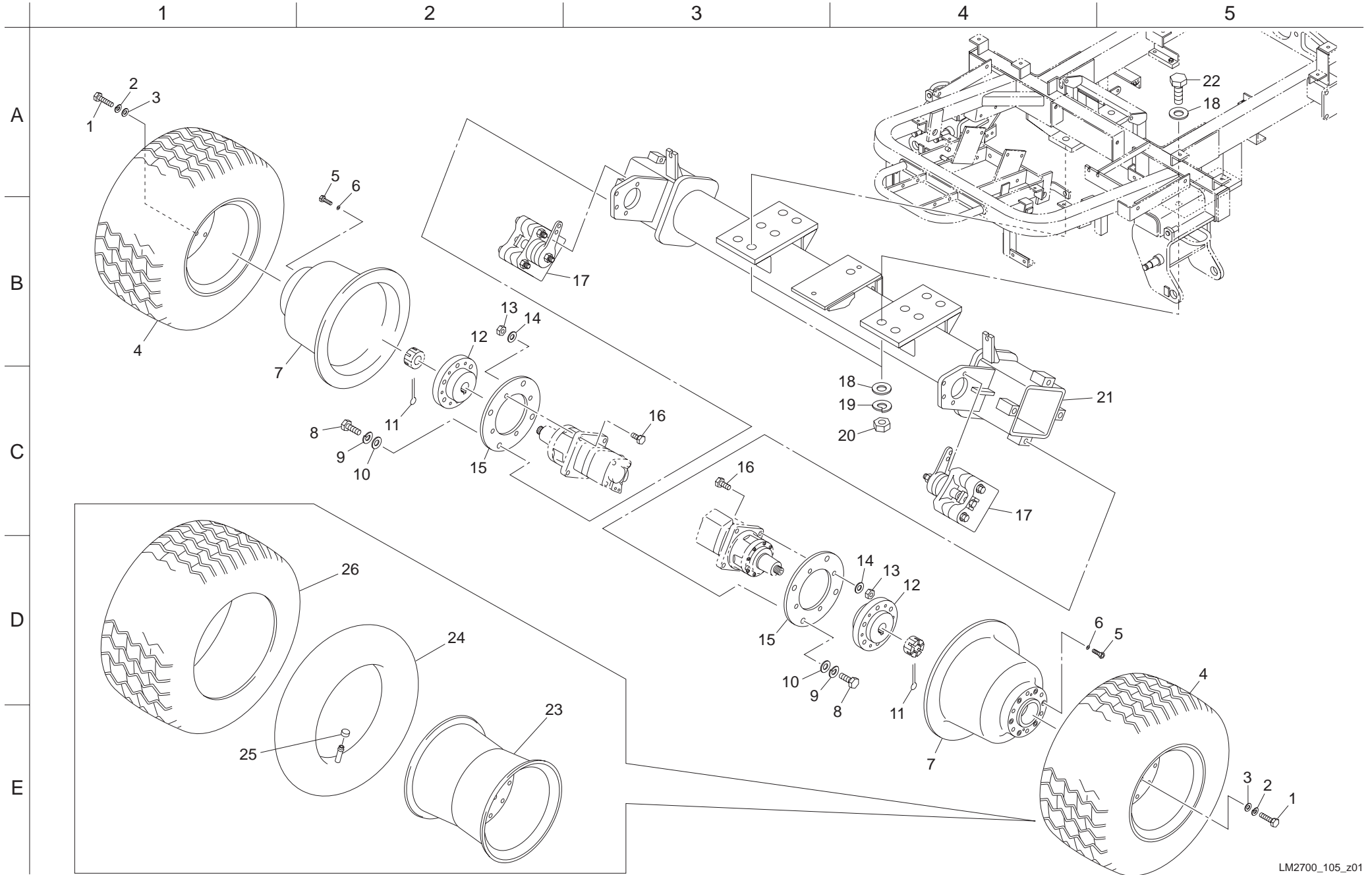

Cat No.	Code No.	Part name	Qty	Remark	SN of application	Cat No.	Code No.	Part name	Qty	Remark	SN of application
105-1	K0014120652	BOLT, HT P1.5 M12-65	12								
105-2	K0200120002	WASHER, SPRING M12	12								
105-3	K5000120002	WASHER, M12	12								
105-4	K2040000510	TIRE ASSY, 26.5*14.00-12TL	2								
105-5	K0024080401	BOLT, WITH HEX. HOLE M8-40	12								
105-6	K0215080002	WASHER, DISK SPRING H M8-2	12								
105-7	LM2700-0305ZD	DISK, BRAKE	2								
105-8	K0014160402	BOLT, HT P1.5 M16-40	8								
105-9	K0200160002	WASHER, SPRING M16	8								
105-10	K5000160002	WASHER, M16	8								
105-11	K0300040502	PIN, COTTER M4-50	2								
105-12	LM2700-0306ZD	MOUNT, WHEEL	2								
105-13	K0100140002	NUT, M14	8								
105-14	K0200140002	WASHER, SPRING M14	8								
105-15	LM2700-0307Z2	PLATE, MOUNTING MOTOR	2								
105-16	K0013140502	BOLT HT M14-50	8								
105-17	K1720000190	BRAKE ASSY, RT	2								
105-18	K5000200002	WASHER, M20	8								
105-19	K0200200002	WASHER, SPRING M20	4								
105-20	K0152200002	NUT, NYLON P1.5 M20	4								
105-21	LM2700-0308ZD	AXLE, FRONT	1								
105-22	K0015200702	BOLT, HT P1.5 M20-70	4								
105-23	K209000079L	WHEEL, 12I*12	2								
105-24	K2091000280	TUBE, 26*14.00-12	2								
105-25	K2093000010	CAP, VALVE	2								
105-26	K2041000300	TIRE, 26.5*14.00-12TL	2								

106. Rear wheel section

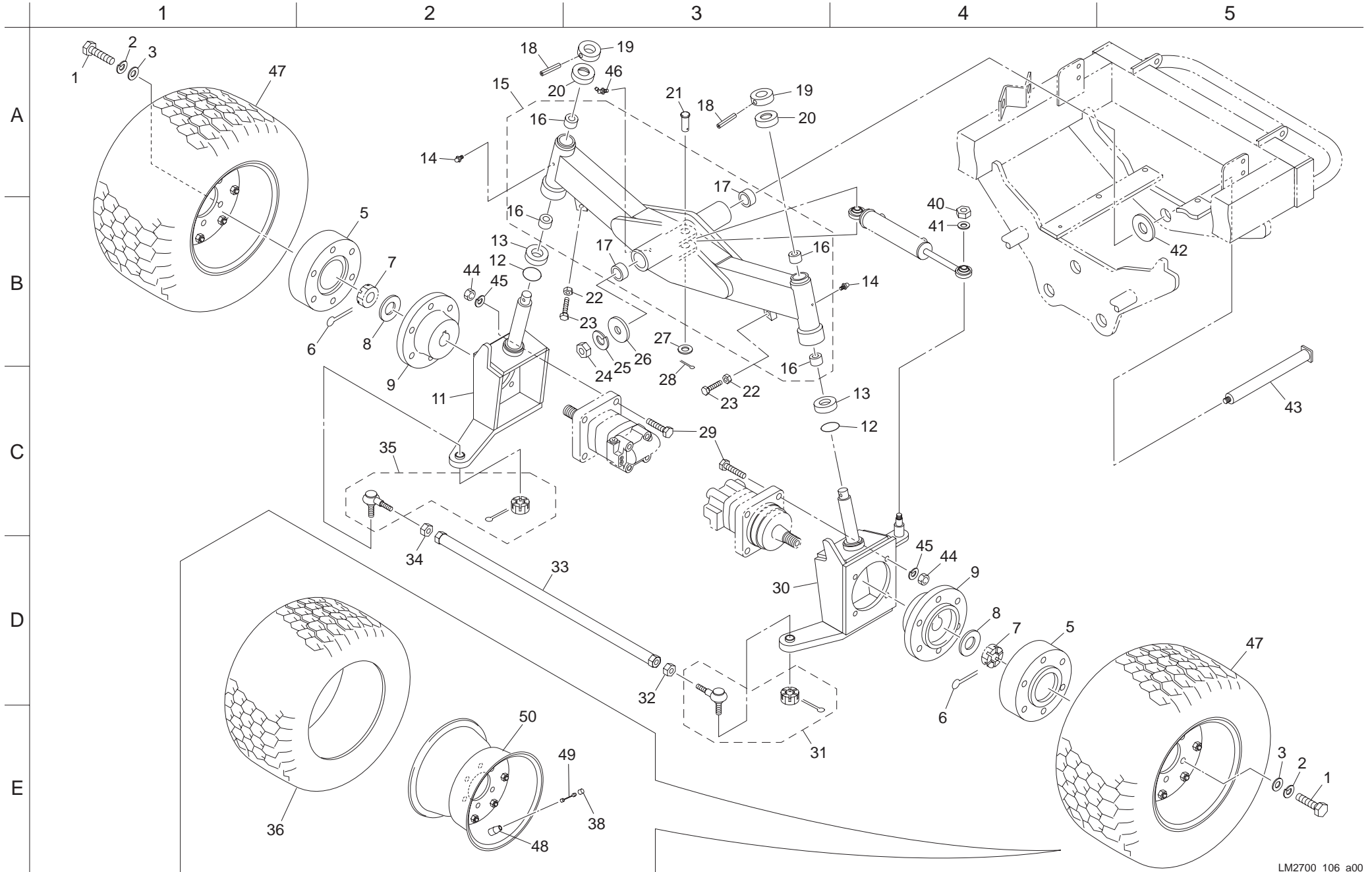

Cat No.	Code No.	Part name	Qty	Remark	SN of application	Cat No.	Code No.	Part name	Qty	Remark	SN of application
106-1	K0014120652	BOLT, HT P1.5 M12-65	12			106-36	K2041000390	TIRE, 20*12.0-10RS	2		
106-2	K0200120002	WASHER, SPRING M12	12			106a-37					
106-3	K5000120002	WASHER, M12	12			106-38	K2093000010	CAP, VALVE	2		
106a-4						106a-39					
106-5	LM2700-0310ZD	SPACER, REAR WHEEL	2			106-40	K0145140002	NUT, WITH F-RING, P1.5 M14	1		
106-6	K0300050452	PIN, COTTER M5-45	2			106-41	K0215140001	WASHER, DISK SPRING H M14-2	1		
106-7	K0138240002	NUT, HIGH SLOTTED P1.5 M24	2			106-42	K5051030500	WASHER, C5191P 1-30-50	1		
106-8	K5000240002	WASHER, M24	2			106-43	K7147000258	SHAFT, WITH M16 THREAD 30316	1		
106-9	GM1500A0240AD	MOUNT, FRONT WHEEL 90	2			106-44	K0100120002	NUT, M12	8		
106-10						106-45	K0200120002	WASHER, SPRING M12	8		
106-11	LM2700-0303AD	KINGPIN, (R)	1			106-46	K1440000030	GREASE NIPPLE, B	1		
106-12	K0880048000	O-RING, P48	2			106a-47	K2040000900	TIRE ASSY, 20*12.0-10	2		
106-13	K0640511070	BEARING, BALL THRUST 51107	2			106a-48	K2097000010	VALVE, RIM TR413	2		
106-14	K1440000010	GREASE NIPPLE, A TYPE	2			106a-49	K2092000010	CORE, VALVE NO.8000	2		
106-15	LM2700-0301AD	PIVOT	1			106a-50	K209000094L	WHEEL, 10*8.5	2		
106-16	K6000000500	BUSH, COPPER 22.3-26-20	4								
106-17	K6000000080	BUSH, COPPER 30-36-30	2								
106-18	K0320080501	PIN, SPRING M8-50	2								
106-19	K6213000113	COLLAR, WITH HOLE M25-50-20	2								
106-20	K6204000383	CAP	2								
106-21	K6031200568	PIN, FLAT HEAD HT M20-56	1								
106-22	K0159000052	NUT, SMALL M12	2								
106-23	K0010120502	BOLT, HT M12-50	2								
106-24	K0100160002	NUT, M16	1								
106-25	K0200160002	WASHER, SPRING M16	1								
106-26	K5073216352	WASHER, SPHC 3.2-16-35	1								
106-27	K5012320402	WASHER, SPCC 2.3-20-40	1								
106-28	K0300032402	PIN, COTTER M3.2-40	1								
106-29	K0010120502	BOLT, HT M12-50	8								
106-30	LM2700-0302AD	KINGPIN, (L)	1								
106-31	K1611000020	TIE-ROD END ASSY, LEFT-HANDED MALE (L)	1								
106-32	K0160000202	NUT, LEFT-HANDED SPECIAL P1.5 M17	1								
106-33	LM2700-0304ZD	ROD, TIE	1								
106-34	K0160000192	NUT, SPECIAL P1.5 M17	1								
106-35	K1610000020	TIE-ROD END ASSY, MALE (R)	1								

107. Pedal section A

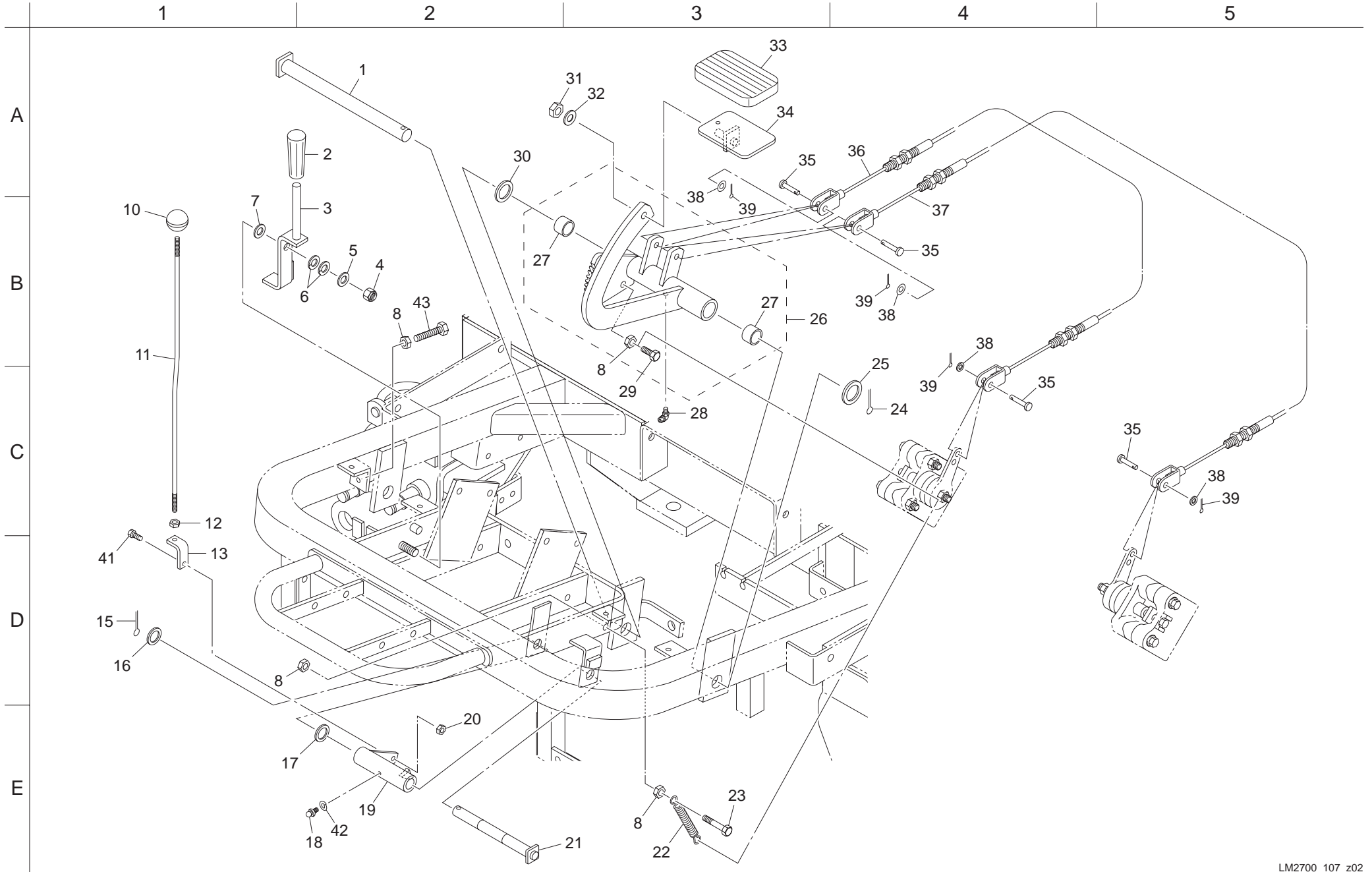

Cat No.	Code No.	Part name	Qty	Remark	SN of application	Cat No.	Code No.	Part name	Qty	Remark	SN of application
107-1	LM2700-0411Z2	SHAFT, PEDAL	1			107-36	K1120238000	WIRE, BRAKE 2380	1		
107-2	K1300000070	GRIP, RUBBER BLACK 9-22	1			107-37	K1120205500	WIRE, BRAKE 2055	1		
107-3	LM2700-0405ZD	STOPPER, DRIVING PEDAL	1			107-38	K5000080002	WASHER, M8	4		
107-4	K0145140002	NUT, WITH F-RING, P1.5 M14	1			107-39	K0300020202	PIN, COTTER M2-20	4		
107-5	K5000140002	WASHER, M14	1			107-40					
107-6	K0210140002	SPRING, CONICAL DISC L M14	2			107-41	K0000060202	BOLT, M6-20	1		
107-7	K5011014202	WASHER, SPCC 1-14-20	1			107-42	K0200060002	WASHER, SPRING M6	1		
107-8	K0100100002	NUT, M10	5			107-43	K0000100352	BOLT, M10-35	2		
107-9											
107-10	K1301000050	GRIP, PLASTIC LEVER	1								
107-11	LM2700-0407Z2	SHAFT, LOCKING	1								
107-12	K0100080002	NUT, M8	1								
107-13	LM2700-0406ZD	ANGLE, LOCK SHAFT	1								
107-14											
107-15	K0300032252	PIN, COTTER M3.2-25	1								
107-16	K5012316282	WASHER, SPCC 2.3-16-28	1								
107-17	K5011016222	WASHER, SPCC 1-16-22	1								
107-18	K1440000010	GREASE NIPPLE, A TYPE	1								
107-19	LM2700-0404ZD	MOUNT, BRAKE SHAFT	1								
107-20	K0144060002	NUT, WITH F-RING, M6	1								
107-21	LM2700-0410Z2	SHAFT, BRAKE	1								
107-22	K1020000088	SPRING, WITH ROUND HOOK M2.3-17-78	1								
107-23	K0003100502	BOLT, M10-50	1								
107-24	K0300032402	PIN, COTTER M3.2-40	1								
107-25	K5012320402	WASHER, SPCC 2.3-20-40	1								
107-26	LM2700-0403ZD	PEDAL, BRAKE	1								
107-27	K6000000280	BUSH, 20-24-20	2								
107-28	K1440000020	GREASE NIPPLE, C	1								
107-29	K0000100202	BOLT, M10-20	1								
107-30	K5011020472	WASHER, SPCC 1-20-47	1								
107-31	K0144100002	NUT, M10 WITH F-RING	1								
107-32	K5000100002	WASHER, M10	1								
107-33	K4050000050	RUBBER, FOR PEDAL 70100	1								
107-34	LM2700-0409AD	PEDAL, A	1								
107-35	K6031080222	PIN, FLAT HEAD HT M8-22	4								

108. Pedal section B

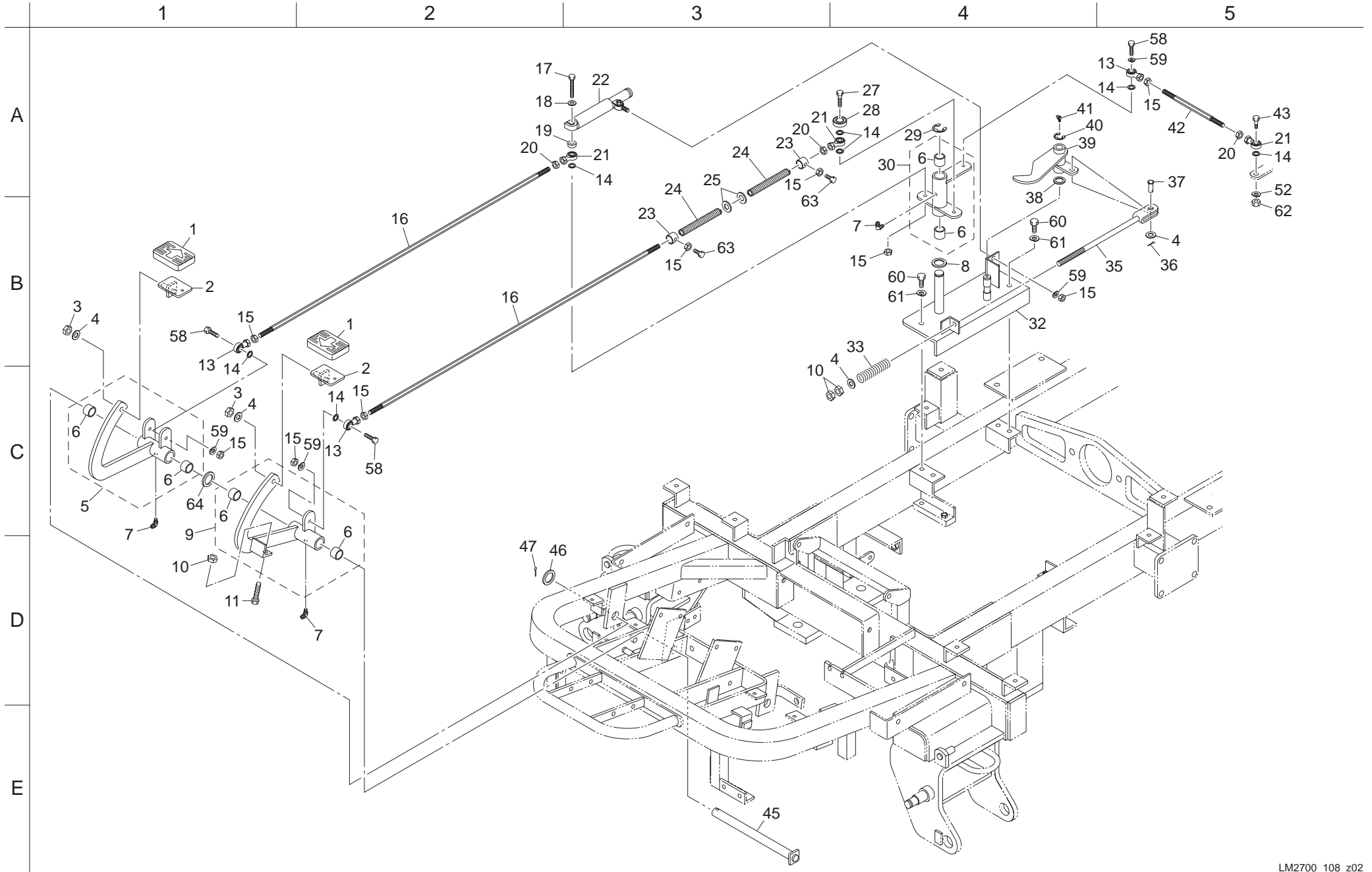

Cat No.	Code No.	Part name	Qty	Remark	SN of application
108-1	LM2700-0420Z0	RUBBER, PEDAL 5575	2		
108-2	LM2700-0408AD	PEDAL, B	2		
108-3	K0144100002	NUT, M10 WITH F-RING	2		
108-4	K5000100002	WASHER, M10	4		
108-5	LM2700-0402AD	PEDAL, BACKWARD	1		
108-6	K6000000280	BUSH, 20-24-20	6		
108-7	K1440000020	GREASE NIPPLE, C	3		
108-8	K5011020472	WASHER, SPCC 1-20-47	1		
108-9	LM2700-0401AD	PEDAL, FORWARD	1		
108-10	K0100100002	NUT, M10	3		
108-11	K0000100302	BOLT, M10-30	1		
108-12					
108-13	K1601080000	JOINT, SPHERICAL PHS8	3		
108-14	K5073208202	WASHER, SPHC 3.2-8-20	7		
108-15	K0100080002	NUT, M8	9		
108-16	LM2700-0415Z2	ROD, THREADED 875	2		
108-17	K0003080552	BOLT, M8-55	1		
108-18	K5000080002	WASHER, M8	1		
108-19	K6212003262	COLLAR, STKM M8.5-14-8	1		
108-20	K0180080002	NUT, LEFT-HANDED M8	3		
108-21	K16010800L0	JOINT, SPHERICAL PHS8LA	3		
108-22	K3380000010	DAMPER, FOR LEVER	1		
108-23	K6218000012	COLLAR, TAPPED M12-22-20	2		
108-24	K1000000558	SPRING, COMPRESSION M2-18-100	2		
108-25	K5000120002	WASHER, M12	2		
108-26					
108-27	LM2700-0418Z2	BOLT, SPECIAL WITH M8	1		
108-28	K0608006290	BEARING, BALL SEAL 2RS 629	1		
108-29	K0400015002	RING, RETAINING E M15	1		
108-30	LM2700-0413Z2	LEVER, CONTROLING PUMP	1		
108-31					
108-32	LM2700-0414Z2	FITTING, NEUTRALIZING PUMP	1		
108-33	K100000082D	SPRING, COMPRESSION M2.6-17.2-70	1		
108-34					
108-35	LM2700-0419Z2	ADJUSTER, LEVER	1		

Cat No.	Code No.	Part name	Qty	Remark	SN of application
108-36	K0300025202	PIN, COTTER M2.5-20	1		
108-37	K6031100258	PIN, FLAT HEAD HT M10-25	1		
108-38	K5011016222	WASHER, SPCC 1-16-22	1		
108-39	LM2700-0412Z2	LEVER, NEUTRALIZING PUMP	1		
108-40	K0400012002	RING, RETAINING E M12	1		
108-41	K1440000030	GREASE NIPPLE, B	1		
108-42	LM2700-0416Z2	ROD, THREADED 170	1		
108-43	LM2700-0417Z2	BOLT, SPECIAL WITH M6	1		
108-44					
108-45	LM2700-0411Z2	SHAFT, PEDAL	1		
108-46	K5012320402	WASHER, SPCC 2.3-20-40	1		
108-47	K0300032402	PIN, COTTER M3.2-40	1		
108-48					
108-49					
108-50					
108-51					
108-52	K0200060002	WASHER, SPRING M6	1		
108-53					
108-54					
108-55					
108-56					
108-57					
108-58	K0000080302	BOLT, M8-30	3		
108-59	K0200080002	WASHER, SPRING M8	4		
108-60	K0000100152	BOLT, M10-15	2		
108-61	K0200100002	WASHER, SPRING M10	2		
108-62	K0100060002	NUT, M6	1		
108-63	K0000080202	BOLT, M8-20	2		
108-64	K5051020320	WASHER, C5191P 1-20-32	1		

109. Engine section A

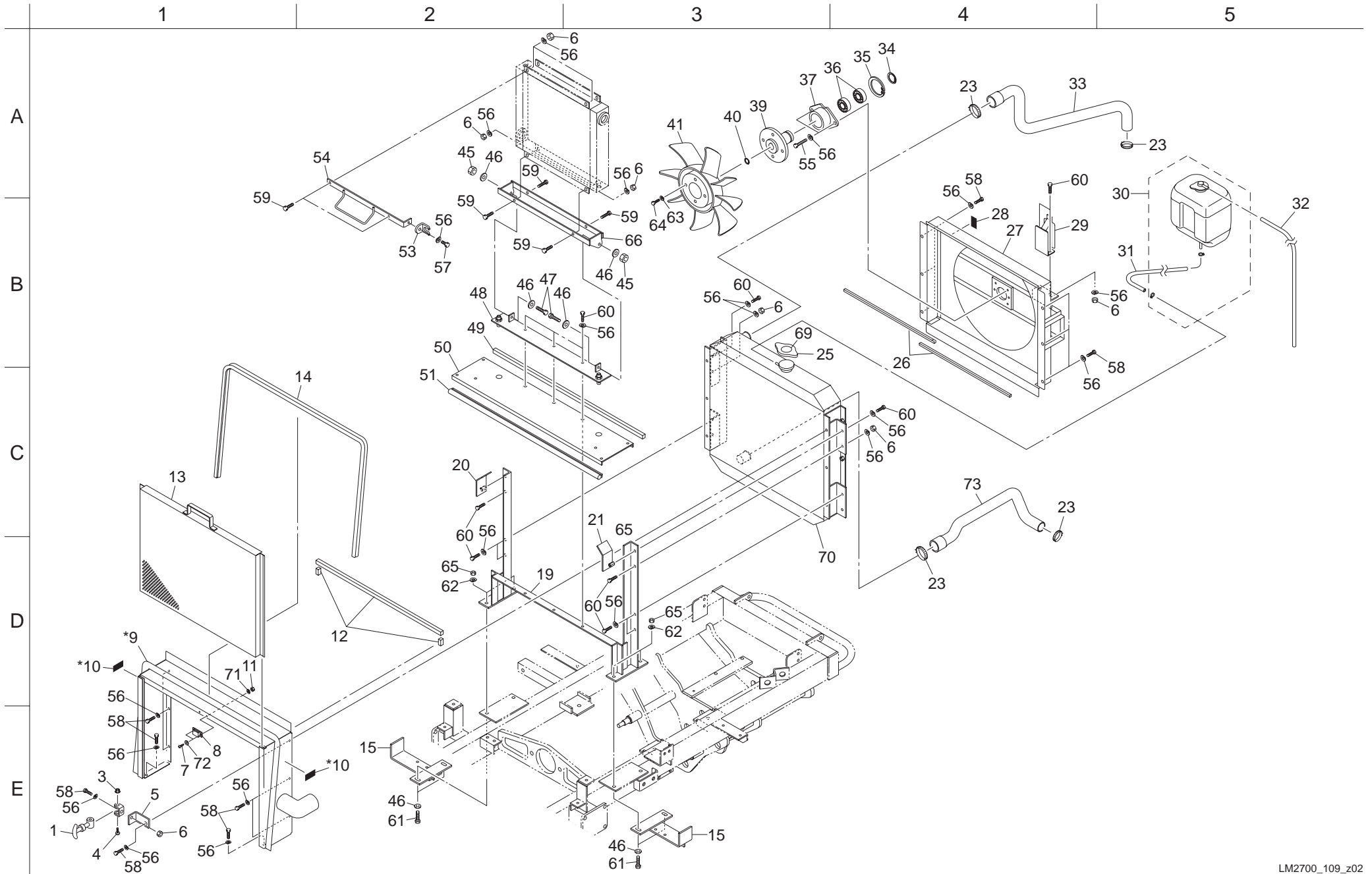

Cat No.	Code No.	Part name	Qty	Remark	SN of application
109-1	K1520000090	HOOK, RUBBER SMALL	1		
109-2					
109-3	K0144060002	NUT, WITH F-RING, M6	1		
109-4	K0000060402	BOLT, M6-40	1		
109-5	LM2700-0542ZD	MOUNT, CATCH (L)	1		
109-6	K0100080002	NUT, M8	11		
109-7	K0042030102	SCREW, + ROUND HEAD M3-10	2		
109-8	K1510000080	MAGNET, CATCH TL-107	1		
109-9	LM2700-3501Z0	FRAME COMP, PROTECTION PLATE	1	*9 includes 10	
109-10	K4205001580	DECAL, CAUTION TO INJURE	1		
109-11	K0100030002	NUT, M3	2		
109-12	K4220000040	SPONGE, URETHAN 15-20700	1		
109-13	LM2700-0544ZD	PLATE, DUST PROOF	1		
109-14	K3198616800	TRIM, SEAL 6100-16A-1680	1		
109-15	LM2700-0936ZD	RECEIVER, HOOD	2		
109-16					
109-17					
109-18					
109-19	LM2700-0509ZD	MOUNT, RADIATOR	1		
109-20	LM2700-0550ZD	GUIDE, ROLLER (R)	1		
109-21	LM2700-0549ZD	GUIDE, ROLLER (L)	1		
109-22					
109-23	K4260000200	CLAMP, HOSE JUBILEE BAND 2A	4		
109-24					
109-25	K2731000010	CAP, RADIATOR	1		
109-26	K4220000220	SPONGE, URETHAN 10-10550	2		
109-27	LM2700-0508ZD	SHROUD	1		
109a-28	K4205001530	DECAL, CAUTION TO ROTATING OBJECT	1		
109-29	PF15527-7246-0	STAY, RESERVE TANK	1		
109-30	PF15501-7240-0	TANK ASSY, RESERVE	1		
109-31	LM2700-0558Z0	HOSE, RADIATOR DRAIN	1		
109-32	LM2700-0559Z0	HOSE, TANK DRAIN	1		
109-33	LM2700-0553Z0	HOSE, RADIATOR UPPER	1		
109-34	K0401025001	RING, RETAINING S M25	1		
109-35	K0402047001	RING, RETAINING R M47	1		

Cat No.	Code No.	Part name	Qty	Remark	SN of application
109-36	K0613060050	BEARING, BALL SEAL 2RDC3 6005	2		
109-37	LM535F-3403Z2	HOUSING, PULLEY	1		
109-38					
109-39	LM2700-0507Z2	MOUNT, COOLING FAN	1		
109-40	K0402013001	RING, RETAINING R M13	1		
109-41	PF16483-7411-0	FAN	1		
109-42					
109-43					
109-44					
109-45	K0144100002	NUT, M10 WITH F-RING	2		
109-46	K5000100002	WASHER, M10	8		
109-47	K0000100252	BOLT, M10-25	2		
109-48	LM2700-0539ZD-Y	RECEIVER, OIL COOLER	1		
109-49	K4220000260	SPONGE, URETHAN 15-15790	1		
109-50	LM2700-0538AD	SILL, DUST PROOF PLATE	1		
109-51	K3198607900	TRIM, SEAL 6100-16A-790	1		
109-52					
109-53	K5270002352	RECEIVER, RUBBER HOOK	1		
109-54	LM2700-0568AD	FITTING, OIL COOLER UPPER	1		
109-55	K0000080302	BOLT, M8-30	2		
109-56	K0200080002	WASHER, SPRING M8	39		
109-57	K0000080102	BOLT, M8-10	1		
109-58	K0000080152	BOLT, M8-15	17		
109-59	K0000080252	BOLT, M8-25	6		
109-60	K0000080202	BOLT, M8-20	15		
109-61	K0000100302	BOLT, M10-30	4		
109-62	K0200100002	WASHER, SPRING M10	4		
109-63	K0200060002	WASHER, SPRING M6	4		
109-64	K0000060152	BOLT, M6-15	4		
109-65	K0100100002	NUT, M10	4		
109-66	LM2700-0578ZD	FITTING, OIL COOLER UNDER	1		
109-67	LM2700-0579ZD	FITTING, U-SHAPED	1		
109-68	K5000080002	WASHER, M8	2		
109a-69					
109-70	LM2710-0527Z0	RADIATOR	1		

109. Engine section A

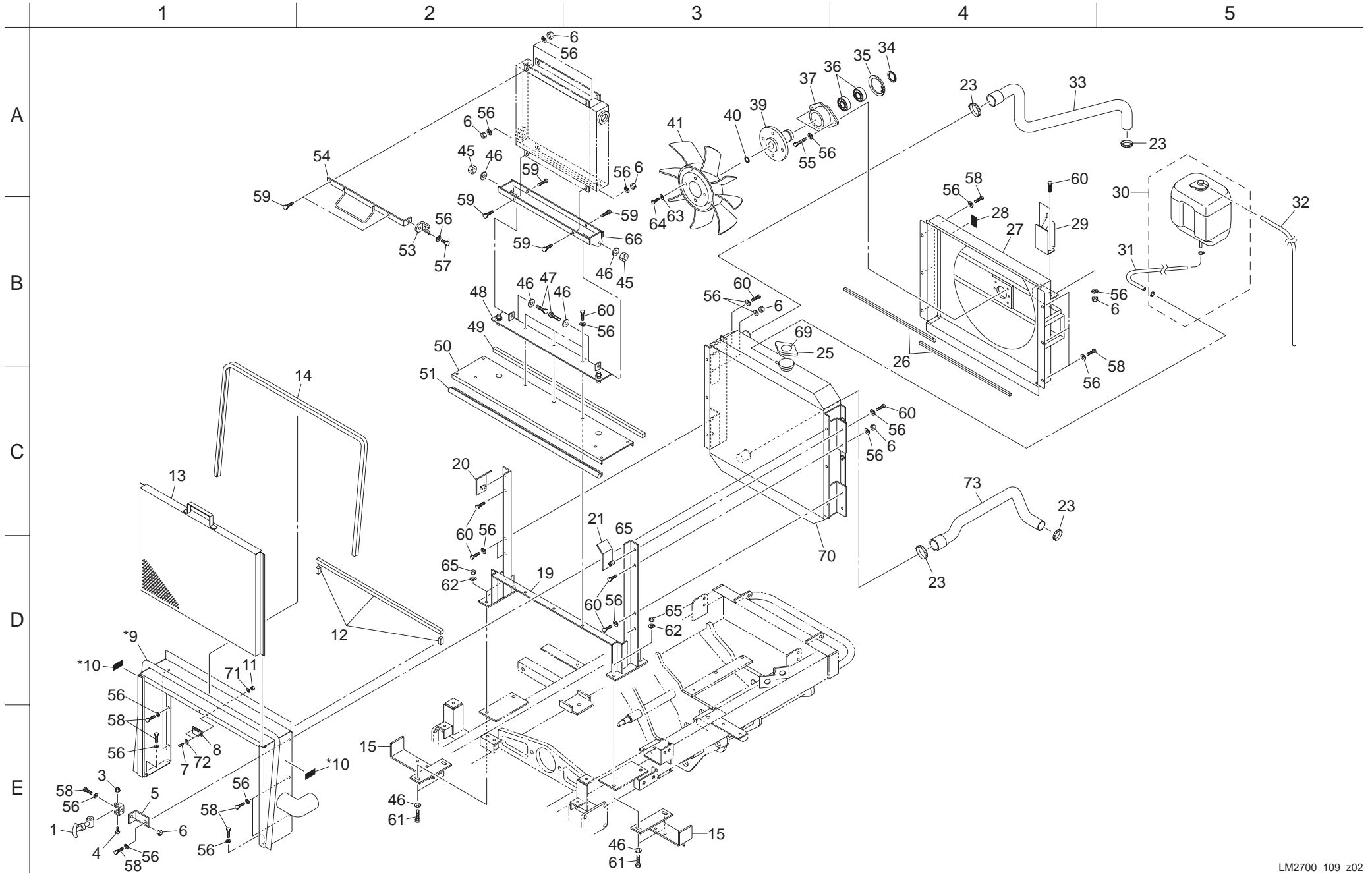

Cat No.	Code No.	Part name	Qty	Remark	SN of application
109-71	K0200030002	WASHER, SPRING M3	2		
109-72	K5000030002	WASHER, M3	2		
109-73	LM2710-0533Z0	HOSE, RADIATOR LOWER	1		

Cat No.	Code No.	Part name	Qty	Remark	SN of application

110. Engine section B

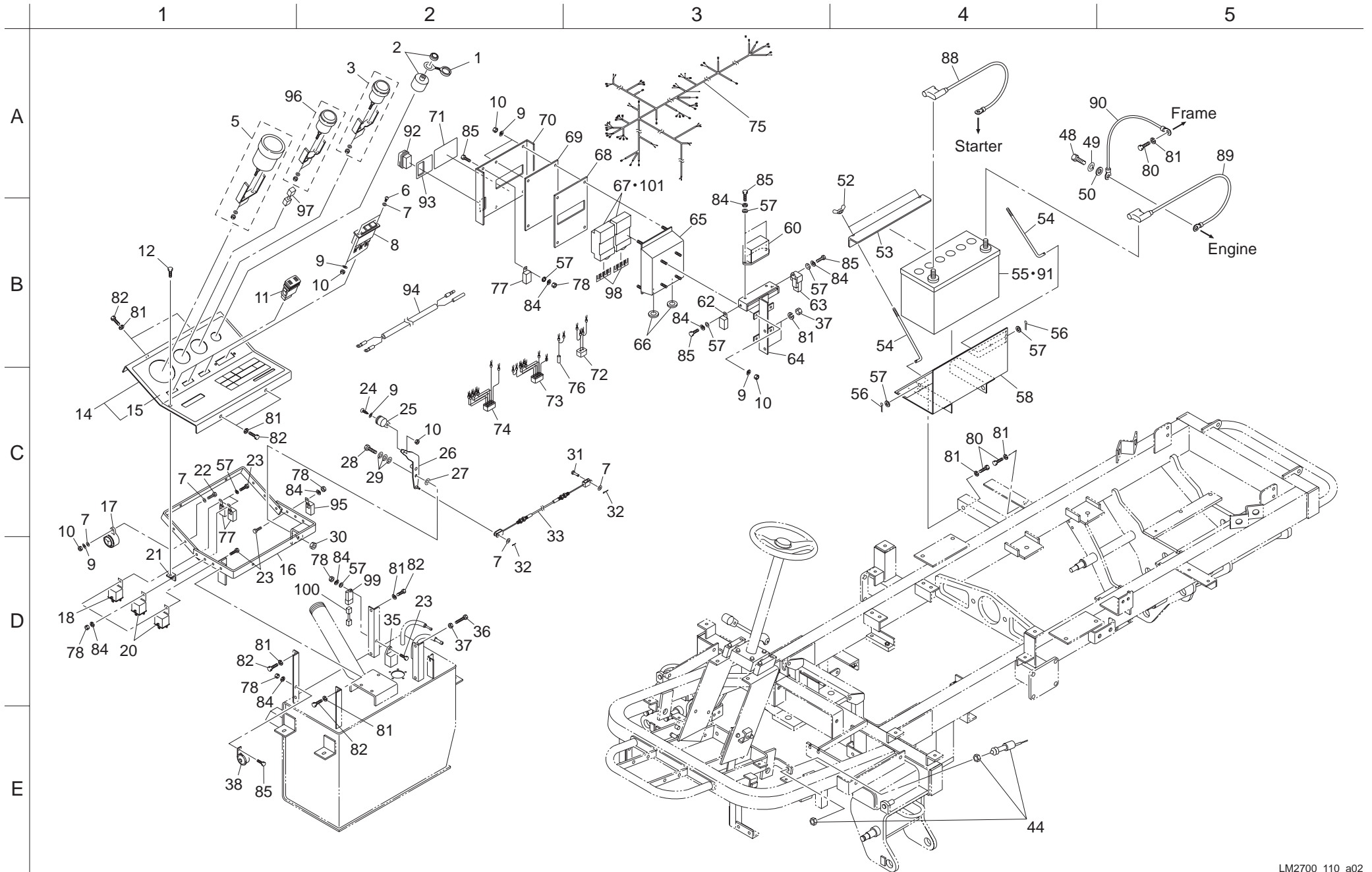

Cat No.	Code No.	Part name	Qty	Remark	SN of application	Cat No.	Code No.	Part name	Qty	Remark	SN of application
110-1	PF54611-4112-0	CAP, STARTER SWITCH	1			110-36	K0000080402	BOLT, M8-40	1		
110-2	PF15248-6359-0	SWITCH ASSY, STARTER	1			110a-37	K0100080002	NUT, M8	3		
110-3	K3653000010	GAUGE, FUEL 52BG2	1			110-38	K3700000030	BUZZER, EBS-12 WITH STAY	1		
110-4						110a-39					
110-5	PF17492-8301-0	HOUR METER ASSY	1			110a-40					
110-6	K0042050122	SCREW, + ROUND HEAD M5-12	2			110-41					
110-7	K5000050002	WASHER, M5	6			110a-42					
110-8	K3641000040	LAMP, PILOT	1			110a-43					
110-9	K0200050002	WASHER, SPRING M5	12			110-44	K3671000150	SWITCH, LIMIT V17680A	1		
110-10	K0100050002	NUT, M5	12			110-45					
110a-11	K3661000050	SWITCH, ROCKER	3			110-46					
110-12	K0062080122	BOLT, BUTTON HEAD WITH HEX. HOLE M8-12	1			110-47					
110-13						110-48	K0002120202	BOLT, P1.25 M12-20	1		
110a-14	LM2700-3902Z0	MOUNT COMP, INSTRUMENT	1			110-49	K0200120002	WASHER, SPRING M12	1		
110a-15	LM2700-0959Z0	STICKER, OPERATION	1			110-50	K5000120002	WASHER, M12	1		
110-16	LM2700-0937ZD	BRACKET, INSTRUMENT	1			110-51					
110-17	K3700000010	BUZZER, EBM-12 TYPE	1			110-52	K0141060002	NUT, WING M6-3	2		
110-18	K3681000080	RELAY, MR5A602A1K	1			110-53	GM2800-0604ZD	CLAMP, BATTERY	1		
110-19						110-54	LM2700-0546ZD	ROD, SUPPORTING BATTERY	2		
110-20	K3681000070	RELAY, MR5A411A1K	2			110-55	K3600000180	BATTERY, FX105D31R	1	mounted from Japan	
110-21	LM2700-0954ZD	ANGLE, TAPPED M3-25-25	1			110-56	K0300016122	PIN, COTTER M1.6-12	2		
110-22	K0000050252	BOLT, M5-25	1			110a-57	K5000060002	WASHER, M6	11		
110a-23	K0000060202	BOLT, M6-20	6			110-58	LM2700-0545ZD	CASE, BATTERY	1		
110-24	K0042050082	SCREW, + ROUND HEAD M5-8	1			110-59					
110-25	K1301000150	GRIP, PLASTIC THROTTLE LEVER	1			110-60	K3630000090	FUSE BLOCK, MINI 10P-A	1		
110-26	LM2700-0560Z2	LEVER, THROTTLE	1			110-61					
110-27	K5011010202	WASHER, SPCC 1-10-20	1			110-62	K3681000060	RELAY, CALAF-12V-N-5	1		
110-28	K0011100302	BOLT, HT P1.25 M10-30	1			110-63	K3630000150	FUSE BLOCK, FUSIBLE LINK 50A	1		
110-29	K0210100002	SPRING, CONICAL DISC L M10	3			110-64	LM2700-0551ZD	BRACKET, BATTERY BOX	1		
110-30	K0103100002	NUT, P1.25 M10	1			110-65	GM2800-0516ZD	RELAY BOX	1		
110-31	K6030050152	PIN, FLAT HEAD M5-15	1			110-66	K0900300160	GROMMET, W/SEALING C30SG16A	2		
110-32	K0300020202	PIN, COTTER M2-20	2			110-67	K3680000030	RELAY BOX, G6B-4CB	2		
110-33	K1110168020	WIRE, THROTTLE 1680	1			110-68	GM2800-0517Z0	PACKING, RUBBER 1-134189	1		
110-34						110-69	GM2800-0518Z0	BOARD, ACRYLIC M 1.5-134189	1		
110-35	PF15694-6599-0	TIMER, GLOW LAMP	1			110a-70	LM2700-0577ZD	CAP, BOX	1		

110. Engine section B

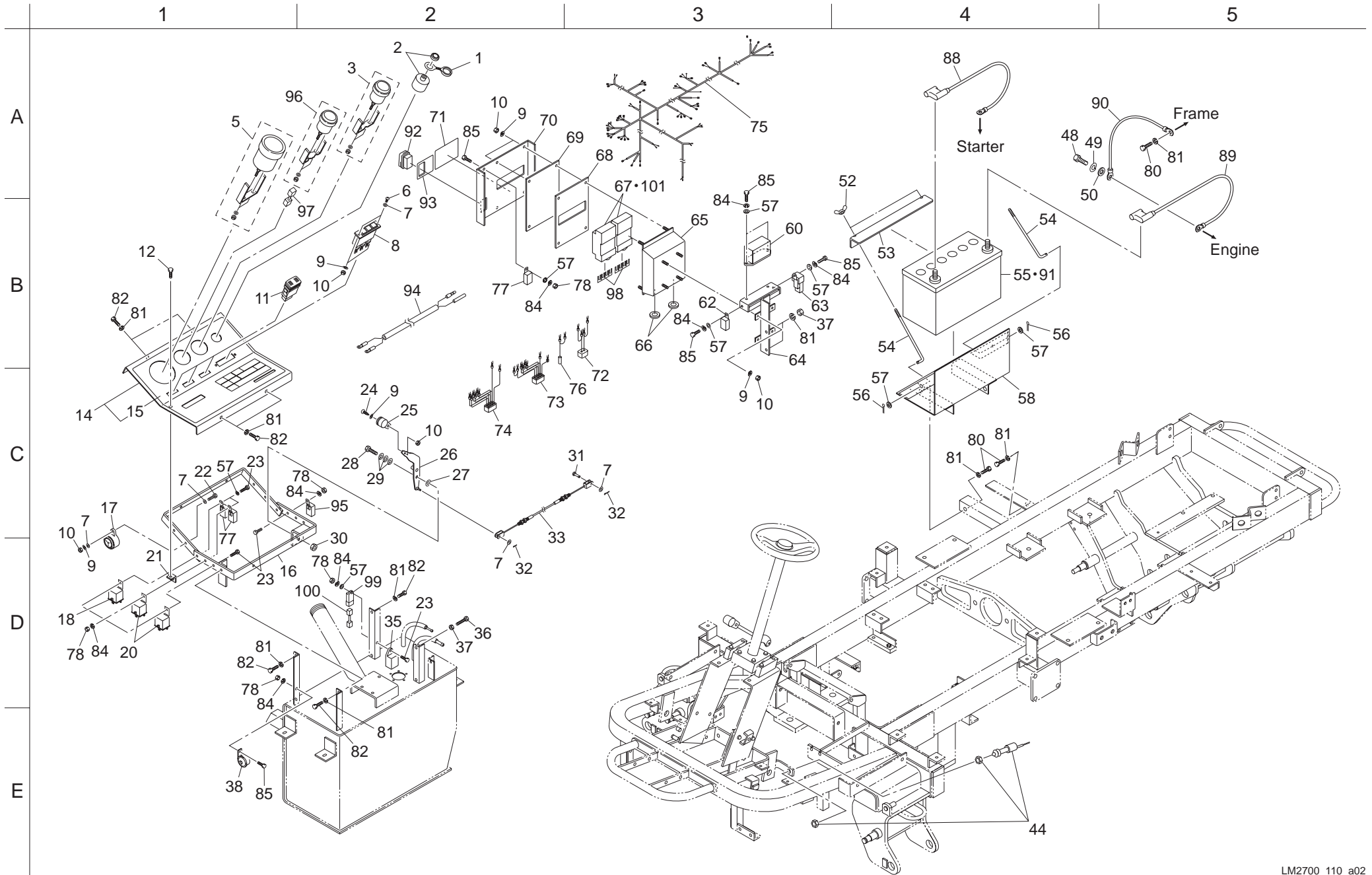

Cat No.	Code No.	Part name	Qty	Remark	SN of application	Cat No.	Code No.	Part name	Qty	Remark	SN of application
110a-71	LM2700-0573Z0	STICKER, BOX COVER	1								
110-72	LM2700-0565Z0	WIRE, RELAY C	1								
110-73	LM2700-0566Z0	WIRE, RELAY A	1								
110-74	LM2700-0567Z0	WIRE, RELAY B	1								
110a-75	LM2700-0576A0	HARNESS	1								
110a-76	LM2700-1901Z0	WIRE, RELAY D	1								
110a-77	K3681000010	RELAY, CA1-DC12V-N	3								
110a-78	K0100060002	NUT, M6	6								
110-79											
110-80	K0000080152	BOLT, M8-15	3								
110-81	K0200080002	WASHER, SPRING M8	12								
110-82	K0000080202	BOLT, M8-20	7								
110-83											
110a-84	K0200060002	WASHER, SPRING M6	11								
110-85	K0000060152	BOLT, M6-15	5								
110-86											
110-87											
110-88	K3610000350	WIRE, BATTERY (+) 750	1								
110-89	K3611000410	WIRE, TO EARTH 600	1								
110-90	K3611000430	CODE, TO EARTH 500	1								
110a-91	K3600000250	BATTERY, EXIDE 27-60	1								
110a-92	K3661000070	SWITCH, ROCKER RED	1								
110a-93	K4205001870	DECAL, LAPPING	1								
110a-94	GM2800-0558Z0	WIRE, LOCKOUT SWITCH	1								
110a-95	K3683000010	TIMER, OFF DELAY 0.9S	1								
110-96	PFR1401-5317-0	GAUGE, WATER TEMPERATURE	1								
110-97	K3620000950	CONNECTOR	1								
110-98	K3680000040	SHORTING BAR, RELAY G6B-4CB	2								
110-99	PF5H276-4125-1	RELAY COMP	1								
110-100	K3620001040	CONNECTOR	1								
110-101	G6B2114P-US-P6B	RELAY, FOR TERMINAL G6B-4CB (REPLACEMENT)	1-8								

111. 26inch Engine section C

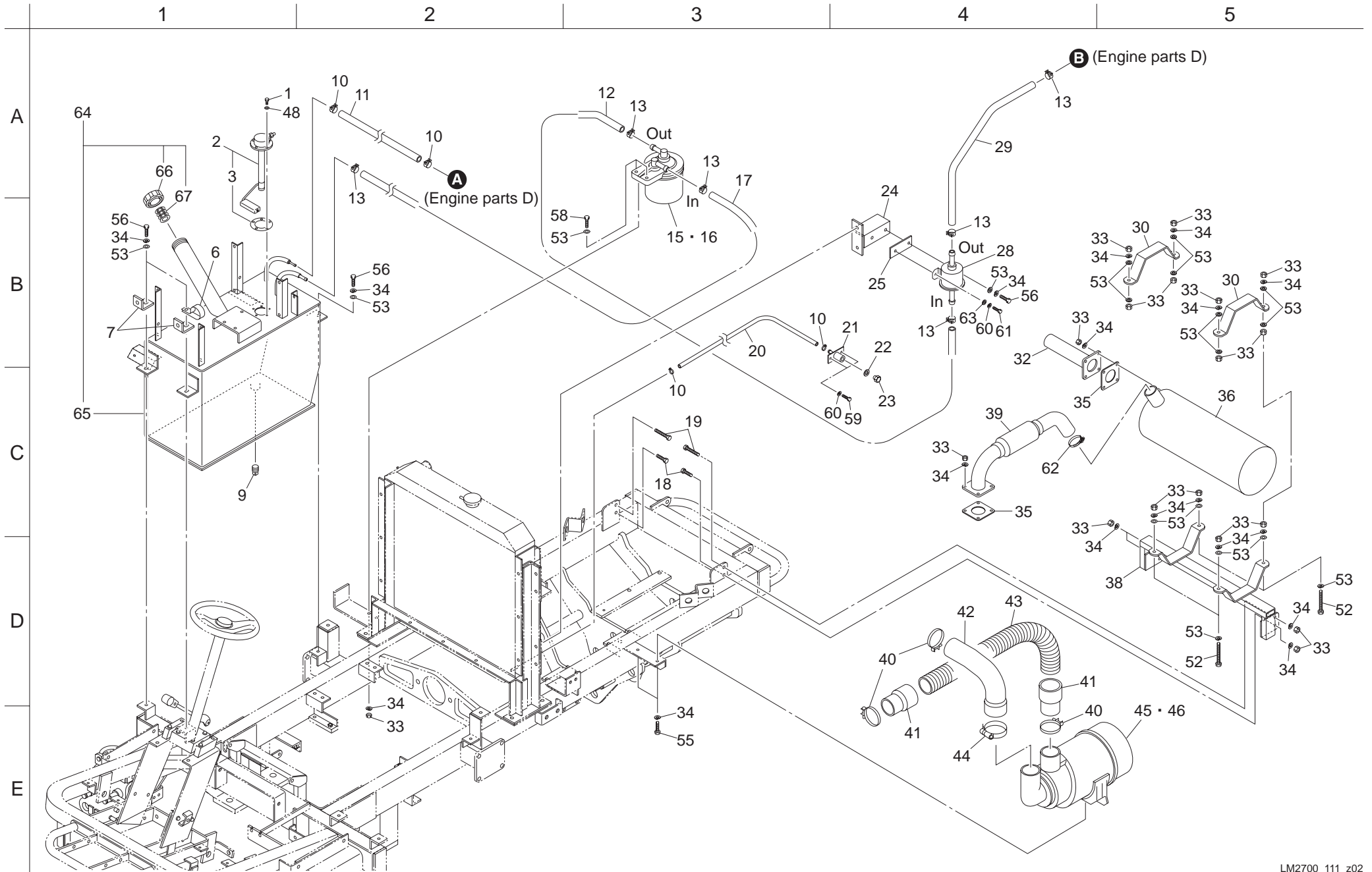

Cat No.	Code No.	Part name	Qty	Remark	SN of application	Cat No.	Code No.	Part name	Qty	Remark	SN of application
111-1	K0000050152	BOLT, M5-15	5			111-36	PF17234-1211-4	MUFFLER	1		
111-2	K2721000090	GAUGE, FLOATING 180*195	1			111-37					
111-3	K2721000020	PACKING, OIL-SHEET	1			111-38	LM2700-0523ZU	STAY, MUFFLER	1		
111-4						111-39	LM2700-0525ZU	PIPE, EXHAUST	1		
111-5						111-40	K4261036000	CLAMP, HOSE 4669	3		
111-6	K4270050080	CLIP, HARNESS 50 M8	1			111-41	K3773000650	CUFF, 65 BANNER A	2		
111-7	LM2700-0950ZD	BRACKET, SIDE COVER	2			111-42	LM2700-0555Z0	HOSE, AIR CLEANER	1		
111-8						111-43	K3170105500	HOSE, 65 BANNER A 550	1		
111-9	K1422106001-Y	PLUG, TAPERED W/ HEX. HOLE T1, 3/8	1			111-44	K4261044000	CLAMP, HOSE PARKER 29-76	1		
111-10	K4260000150	CLAMP, HOSE 12	4			111-45	PF1G369-1101-0	AIR CLEANER ASSY	1		
111-11	K3182014000	HOSE, FUEL 4*1B1400	1			111-46	PFR1401-4227-0	ELEMENT, OUTER	1		
111-12	K3180011000	HOSE, FUEL 8*1B1100	1			111-47					
111-13	K4260000172	CLAMP, HOSE 12	6			111-48	K0922050000	SEAL, WASHER 5WF	5		
111-14						111-49					
111-15	PF15224-4301-0	FILTER ASSY, FUEL	1			111-50					
111-16	PF15221-4317-0	ELEMENT, FUEL FILTER	1			111-51					
111-17	K3180007000	HOSE, FUEL 8*1B 700	1			111-52	K0000080502	BOLT, M8-50	4		
111-18	K0000080202	BOLT, M8-20	2			111-53	K5000080002	WASHER, M8	22		
111-19	K0000080402	BOLT, M8-40	2			111-54					
111-20	LM2700-0558Z0	HOSE, RADIATOR DRAIN	1			111-55	K0000080152	BOLT, M8-15	3		
111-21	LM2700-0561Z2	JOINT	1			111-56	K0000080202	BOLT, M8-20	3		
111-22	LM2700-0562Z0	PACKING	1			111-57					
111-23	LM2700-0563Z0	PLUG, DRAIN	1			111-58	K0000080252	BOLT, M8-25	2		
111-24	LM2700-0548ZD	BRACKET, PUMP	1			111-59	K0000060152	BOLT, M6-15	2		
111-25	PF66591-5456-3	RUBBER, VIBRATION PROOF	1			111-60	K0200060002	WASHER, SPRING M6	2		
111-26						111-61	K0000060202	BOLT, M6-20	1		
111-27						111-62	K4260000200	CLAMP, HOSE JUBILEE BAND 2A	1		
111-28	PFR1401-5135-2	PUMP ASSY, FUEL	1			111-63	K5000060002	WASHER, M6	1		
111-29	K3180006000	HOSE, FUEL 8*1B600	1			111-64	LM2700-0703Z0	TANK ASSY, FUEL W/ CAP	1		
111-30	LM2700-0524ZU	PLATE, MOUNTING MUFFLER	2			111-65	LM2700-0702AD-Y	TANK, FUEL	1		
111-31						111-66	K1410000120	PLUG, FUEL TANK	1		
111-32	LM2700-0527ZU	PIPE, TAIL	1			111-67	K3420000080	STRAINER, FUEL	1		
111-33	K0100080002	NUT, M8	26								
111-34	K0200080002	WASHER, SPRING M8	28								
111-35	PFT0070-1642-0	GASKET, MUFFLER	2								

112. 22inch Engine section C

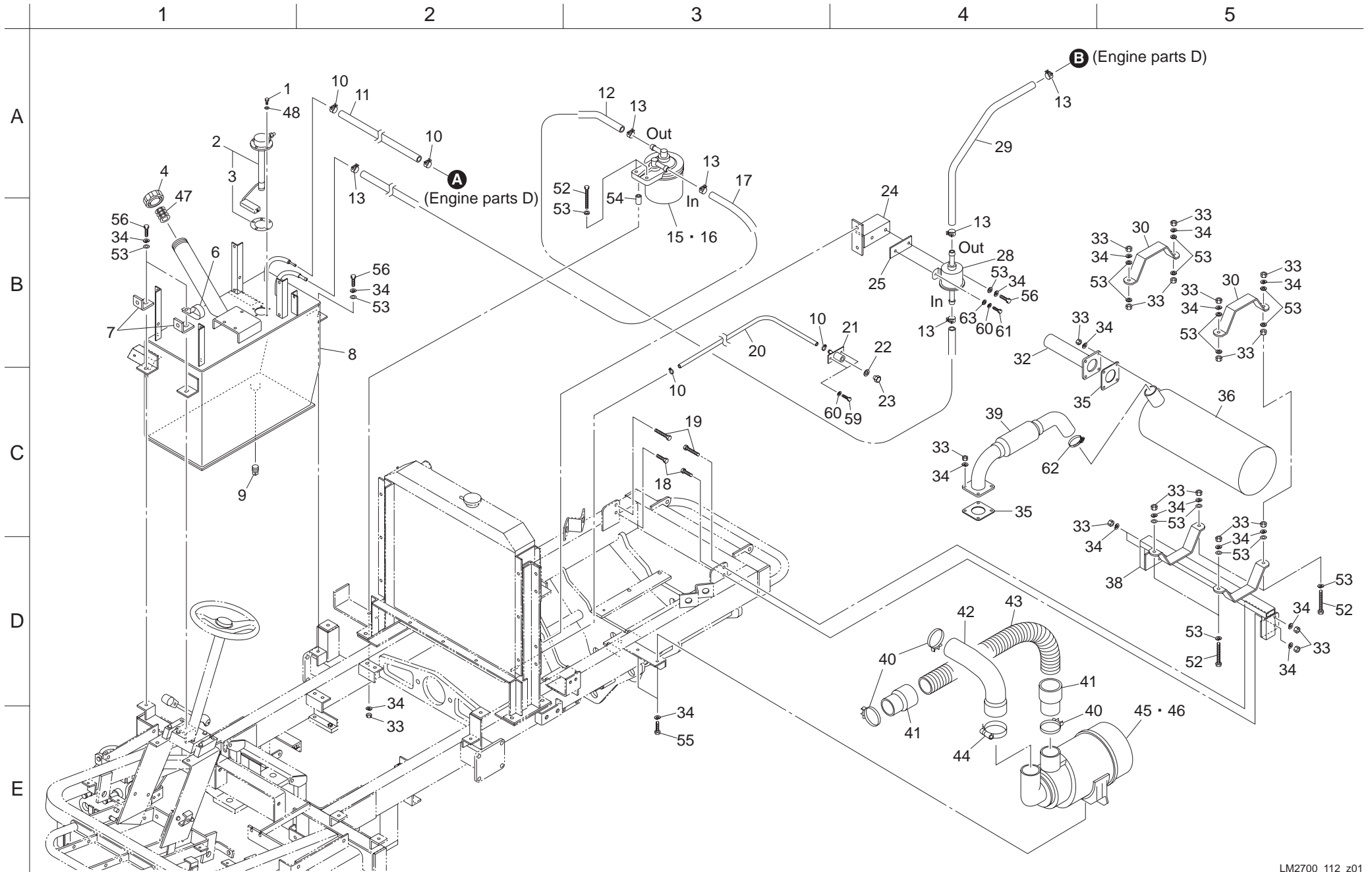

Cat No.	Code No.	Part name	Qty	Remark	SN of application	Cat No.	Code No.	Part name	Qty	Remark	SN of application
112-1	K0000050152	BOLT, M5-15	5			112-36	PF17234-1211-4	MUFFLER	1		
112-2	K2721000090	GAUGE, FLOATING 180*195	1			112-37					
112-3	K2721000020	PACKING, OIL-SHEET	1			112-38	LM2700-0523ZU	STAY, MUFFLER	1		
112-4	K1410000070-Y	PLUG, OIL WITH AIR HOLE	1			112-39	LM2700-0525ZU	PIPE, EXHAUST	1		
112-5						112-40	K4261036000	CLAMP, HOSE 4669	3		
112-6	K4270050080	CLIP, HARNESS 50 M8	1			112-41	K3773000650	CUFF, 65 BANNER A	2		
112-7	LM2700-0950ZD	BRACKET, SIDE COVER	2			112-42	LM2700-0555Z0	HOSE, AIR CLEANER	1		
112-8	LM2700-0702ZD-Y	TANK, FUEL	1			112-43	K3170105500	HOSE, 65 BANNER A 550	1		
112-9	K1422106001-Y	PLUG, TAPERED W/ HEX. HOLE T1, 3/8	1			112-44	K4261044000	CLAMP, HOSE PARKER 29-76	1		
112-10	K4260000150	CLAMP, HOSE 12	4			112-45	PF1G369-1101-0	AIR CLEANER ASSY	1		
112-11	K3182014000	HOSE, FUEL 4*1B1400	1			112-46	PFR1401-4227-0	ELEMENT, OUTER	1		
112-12	K3180011000	HOSE, FUEL 8*1B1100	1			112-47	K3420000030	STRAINER, FUEL	1		
112-13	K4260000172	CLAMP, HOSE 12	6			112-48	K0922050000	SEAL, WASHER 5WF	5		
112-14						112-49					
112-15	PF15224-4301-0	FILTER ASSY, FUEL	1			112-50					
112-16	PF15221-4317-0	ELEMENT, FUEL FILTER	1			112-51					
112-17	K3180007000	HOSE, FUEL 8*1B 700	1			112-52	K0000080502	BOLT, M8-50	6		
112-18	K0000080202	BOLT, M8-20	2			112-53	K5000080002	WASHER, M8	22		
112-19	K0000080402	BOLT, M8-40	2			112-54	K6212001582	COLLAR, STKM M8.5-17-22	2		
112-20	LM2700-0558Z0	HOSE, RADIATOR DRAIN	1			112-55	K0000080152	BOLT, M8-15	3		
112-21	LM2700-0561Z2	JOINT	1			112-56	K0000080202	BOLT, M8-20	3		
112-22	LM2700-0562Z0	PACKING	1			112-57					
112-23	LM2700-0563Z0	PLUG, DRAIN	1			112-58					
112-24	LM2700-0548ZD	BRACKET, PUMP	1			112-59	K0000060152	BOLT, M6-15	2		
112-25	PF66591-5456-3	RUBBER, VIBRATION PROOF	1			112-60	K0200060002	WASHER, SPRING M6	2		
112-26						112-61	K0000060202	BOLT, M6-20	1		
112-27						112-62	K4260000200	CLAMP, HOSE JUBILEE BAND 2A	1		
112-28	PFR1401-5135-2	PUMP ASSY, FUEL	1			112-63	K5000060002	WASHER, M6	1		
112-29	K3180006000	HOSE, FUEL 8*1B600	1								
112-30	LM2700-0524ZU	PLATE, MOUNTING MUFFLER	2								
112-31											
112-32	LM2700-0527ZU	PIPE, TAIL	1								
112-33	K0100080002	NUT, M8	26								
112-34	K0200080002	WASHER, SPRING M8	28								
112-35	PFT0070-1642-0	GASKET, MUFFLER	2								

113. Engine section D

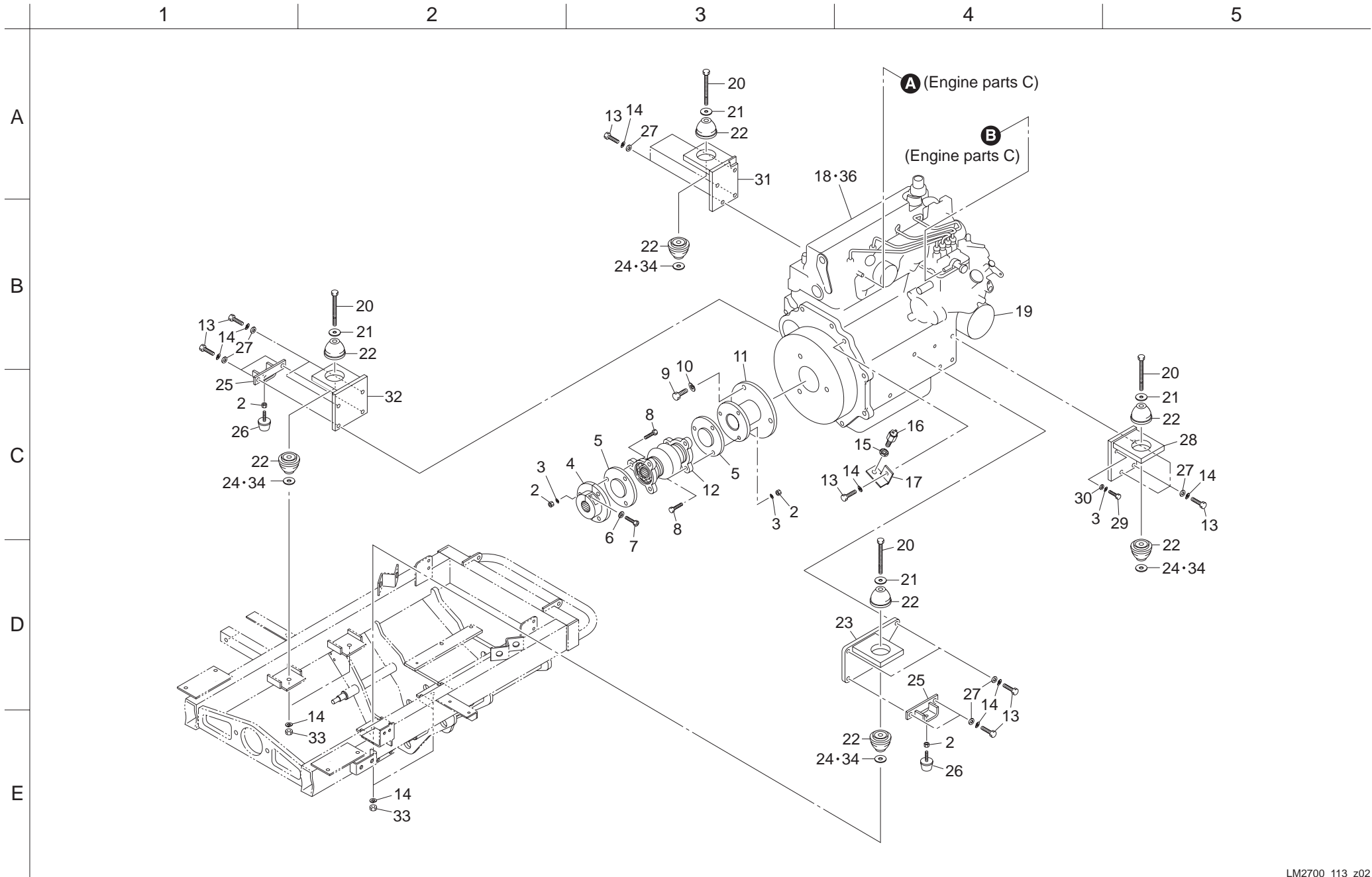

Cat No.	Code No.	Part name	Qty	Remark	SN of application	Cat No.	Code No.	Part name	Qty	Remark	SN of application
113-1						113-36	PF17112-9701-2	FAN BELT	1		
113-2	K0100100002	NUT, M10	8								
113-3	K0200100002	WASHER, SPRING M10	7								
113-4	K6204000572	DISK, DRIVING PUMP SIDE	1								
113-5	K6204000562	SPACER, 118	2								
113-6	K0215100002	WASHER, DISK SPRING H M10-2	1								
113-7	K0024100401	BOLT, WITH HEX. HOLE M10-40	1								
113-8	K0010100402	BOLT, HT M10-40	6								
113-9	K0010140302	BOLT, HT M14-30	3								
113-10	K0200140002	WASHER, SPRING M14	3								
113-11	LM2700-0501Z2	ADAPTOR, FLYWHEEL	1								
113-12	K1620000270	JOINT,BC75ACCP230	1								
113-13	K0012120352	BOLT, HT P1.25 M12-35	16								
113-14	K0200120002	WASHER, SPRING M12	20								
113-15	K0160000142	NUT, SPECIAL P1.5 M18	1								
113-16	PF56713-4293-0	PICKUP, ELECTROMAGNETIC	1								
113-17	LM2700-0531ZD	FITTING, ELECTROMAGNETIC PICKUP	1								
113-18	LM2700-0590A0	ENGINE, V2203-M-E3B-LMKY-1	1								
113-19	PF16414-3243-4	FILTER (OIL CARTRIDGE)	1								
113-20	K0013121102	BOLT, HT M12-110	4								
113-21	K5076012402	WASHER, SPHC 6-12-40	4								
113-22	K4042000100	RUBBER, VIBRATION PROOF TO MOUNT ENGINE	8								
113-23	LM2700-0504ZD	BRACKET, ENGINE C	1								
113-24	K5011613402	WASHER, SPCC 1.6-13-40	4	for adjustment							
113-25	LM2700-0564AD	MOUNT, RUBBER STOPPER	2								
113-26	K4049050000	STOPPER, RUBBER KI-50	2								
113-27	K5000120002	WASHER, M12	15								
113-28	LM2700-0505ZD	BRACKET, ENGINE D	1								
113-29	K0011100302	BOLT, HT P1.25 M10-30	1								
113-30	K5000100002	WASHER, M10	1								
113-31	LM2700-0503ZD	BRACKET, ENGINE B	1								
113-32	LM2700-0502ZD	BRACKET, ENGINE A	1								
113-33	K0100120002	NUT, M12	4								
113-34	K5012313402	Washer, SPCC 2.3-13-40	4	for adjustment							
113-35											

114. Hydraulic section A

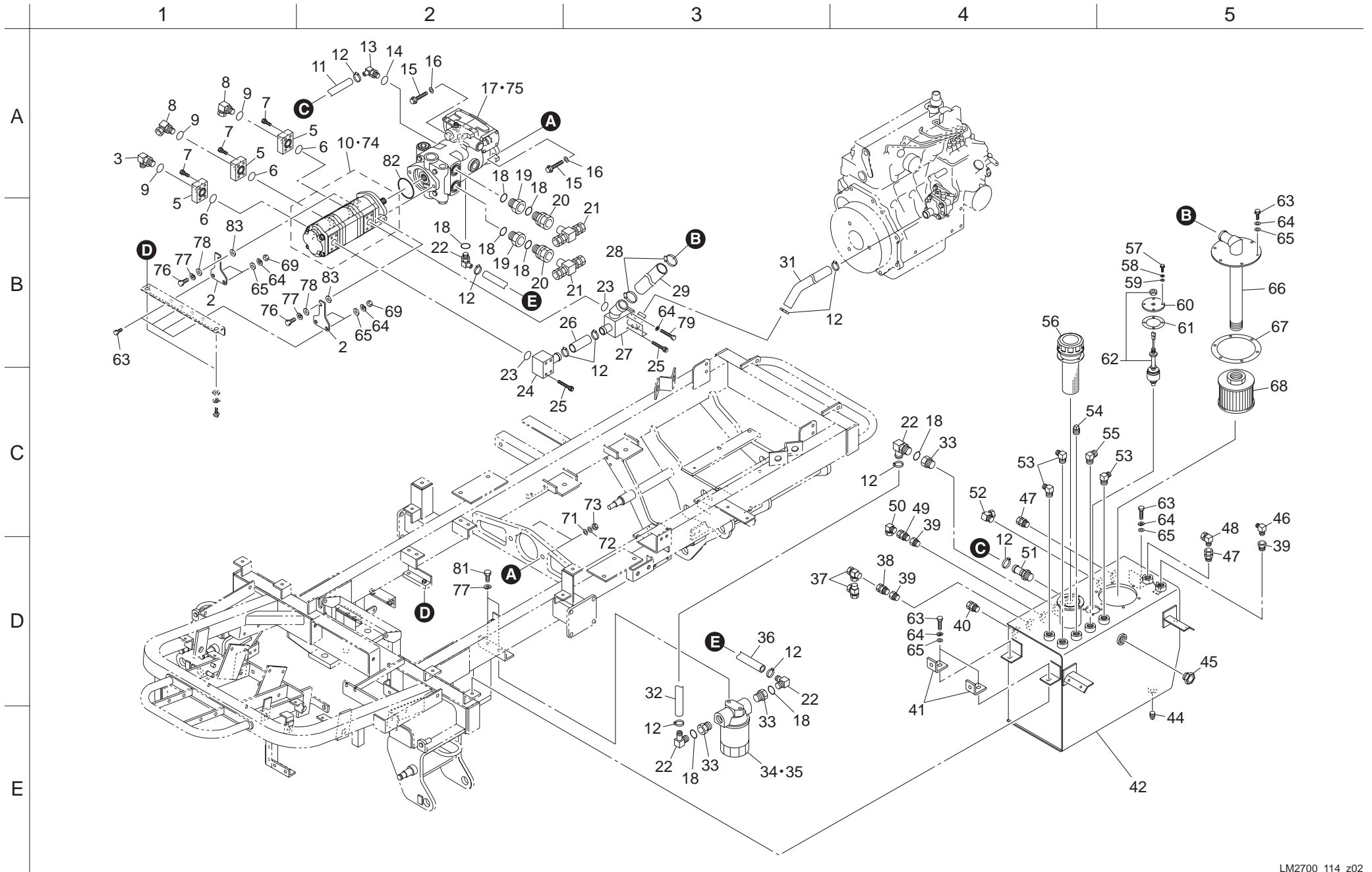

Cat No.	Code No.	Part name	Qty	Remark	SN of application
114-1					
114-2	LM2700-0803ZD	BRACKET, PUMP	2		
114-3	K3008000352-Y	ELBOW, 90 DEG. ODD SIZED PF3/8 PF1/2	1		
114-4					
114-5	LM2700-0830Z2-Y	FLANGE, DISCHARGE	3		
114-6	K0881028000	O-RING, P28B	3		
114-7	K0024080251	BOLT, WITH HEX. HOLE M8-25	12		
114-8	K3026412081-Y	NIPPLE, KLO 12-040E	2		
114-9	K0881018000	O-RING, P18B	3		
114-10	K3252000040	PUMP, GEAR PBBBB222	1		
114-11	LM2700-0870A0	HOSE, SUCTION 25-630	1		
114-12	K4260000190	CLAMP, HOSE JUBILEE BAND 1	10		
114-13	K3008000302-Y	ADAPTOR, FPD21941	1		
114-14	K0887009120	O-RING, AS568-912	1		
114-15	K0010120502	BOLT, HT M12-50	2		
114-16	K5073212352	WASHER, SPHC 3.2-12-35	2		
114-17	K3244000040	PUMP, PISTON 72400	1		
114-18	K0887009160	O-RING, AS568-916	8		
114-19	K3008000632-Y	CONNECTOR, WITH O-RING 4043-1 5/16-0	2		
114-20	K3008000622-Y	CONNECTOR, WITH O-RING 1202-25-1 5/16	2		
114-21	K3027025001-Y	TEE, KTB 25-000E	2		
114-22	K3008000312-Y	ADAPTOR, FPD21939	4		
114-23	K0883025000	O-RING, G25B	2		
114-24	LM2700-0805A2-Y	FLANGE, SUCTION	1		
114-25	K0024080601	BOLT, WITH HEX. HOLE M8-60	7		
114-26	LM2700-3844A0	HOSE, BYPASS	1		
114-27	LM2700-0804B2-Y	FLANGE, COMMON SUCTION	1		
114-28	K4260000200	CLAMP, HOSE JUBILEE BAND 2A	2		
114-29	LM2700-0872Z0	HOSE, SUCTION 38-390	1		
114-30					
114-31	LM2700-0871A0	HOSE, SUCTION 25-780	1		
114-32	LM2700-0868A0	HOSE, SUCTION 25-210	1		
114-33	K3008000642-Y	CONNECTOR, WITH O-RING 4400-25-16	3		
114-34	K3410000020	FILTER, CARTRIDGE CF-80-10U	1		
114-35	K3410000030	FILTER, CARTRIDGE F-913-1 (SUBSTITUTE)	1		

Cat No.	Code No.	Part name	Qty	Remark	SN of application
114-36	LM2700-0869A0	HOSE, SUCTION25-140	1		
114-37	K3027210001-Y	TEE, KTC 10-000E	2		
114-38	K3026610061-Y	CONNECTOR, KCT 10-030E	1		
114-39	K3020080601-Y	BUSHING, BUT 1/2*3/8	3		
114-40	K3026612081-Y	CONNECTOR, KCT 12-040E	1		
114-41	LM2700-0950ZD	BRACKET, SIDE COVER	2		
114-42	LM2700-0801BD-Y	TANK, HYDRAULIC	1		
114-43					
114-44	K1422106001-Y	PLUG, TAPERED W/ HEX. HOLE T1, 3/8	1		
114-45	K1400000044-Y	GAUGE, OIL M TYPEPF3/4	1		
114-46	K3006000012-Y	ELBOW, ODD SIZED PT3/8*PF1/4	1		
114-47	K3026610081-Y	CONNECTOR, KCT 10-040E	2		
114-48	K3027110001-Y	ELBOW, KLC 10-000E	1		
114-49	K3026612061-Y	CONNECTOR, KCT 12-030E	1		
114-50	K3027112001-Y	ELBOW, KLC 12-000E	1		
114-51	K3009000132-Y	ADAPTOR, MO-JS-25	1		
114-52	K3028012081-Y	ELBOW, KLN 12-040E	1		
114-53	K3006000022-Y	ELBOW, ODD SIZED PT1/2*PF3/8	3		
114-54	K1422108001-Y	PLUG, TAPERED W/ HEX. HOLE T1, 1/2	1		
114-55	K3001120002-Y	ELBOW, 90 DEG 1033-12	1		
114-56	K3400000030	BREATHER, REFUELING HOLE FAB-50	1		
114-57	K0000060202	BOLT, M6-20	4		
114-58	K0200060002	WASHER, SPRING M6	4		
114-59	K5000060002	WASHER, M6	4		
114-60	LM526--0809Z2-Y	BRACKET, OIL LEVEL SENSOR	1		
114-61	K4011000330	PACKING, OIL-SHEET 0.8-4575	1		
114-62	K3720000130	SENSOR, LEVEL SWITCH	1		
114-63	K0000080202	BOLT, M8-20	12		
114-64	K0200080002	WASHER, SPRING M8	14		
114-65	K5000080002	WASHER, M8	13		
114-66	LM2700-0802Z2-Y	ATTACHMENT, SUCTION HOSE	1		
114-67	LM535E-0434Z0	PACKING, SUCTION PORT	1		
114-68	K3413000040	FILTER, SUCTION SFT-10-150W	1		
114-69	K0100080002	NUT, M8	4		
114-70					

114. Hydraulic section A

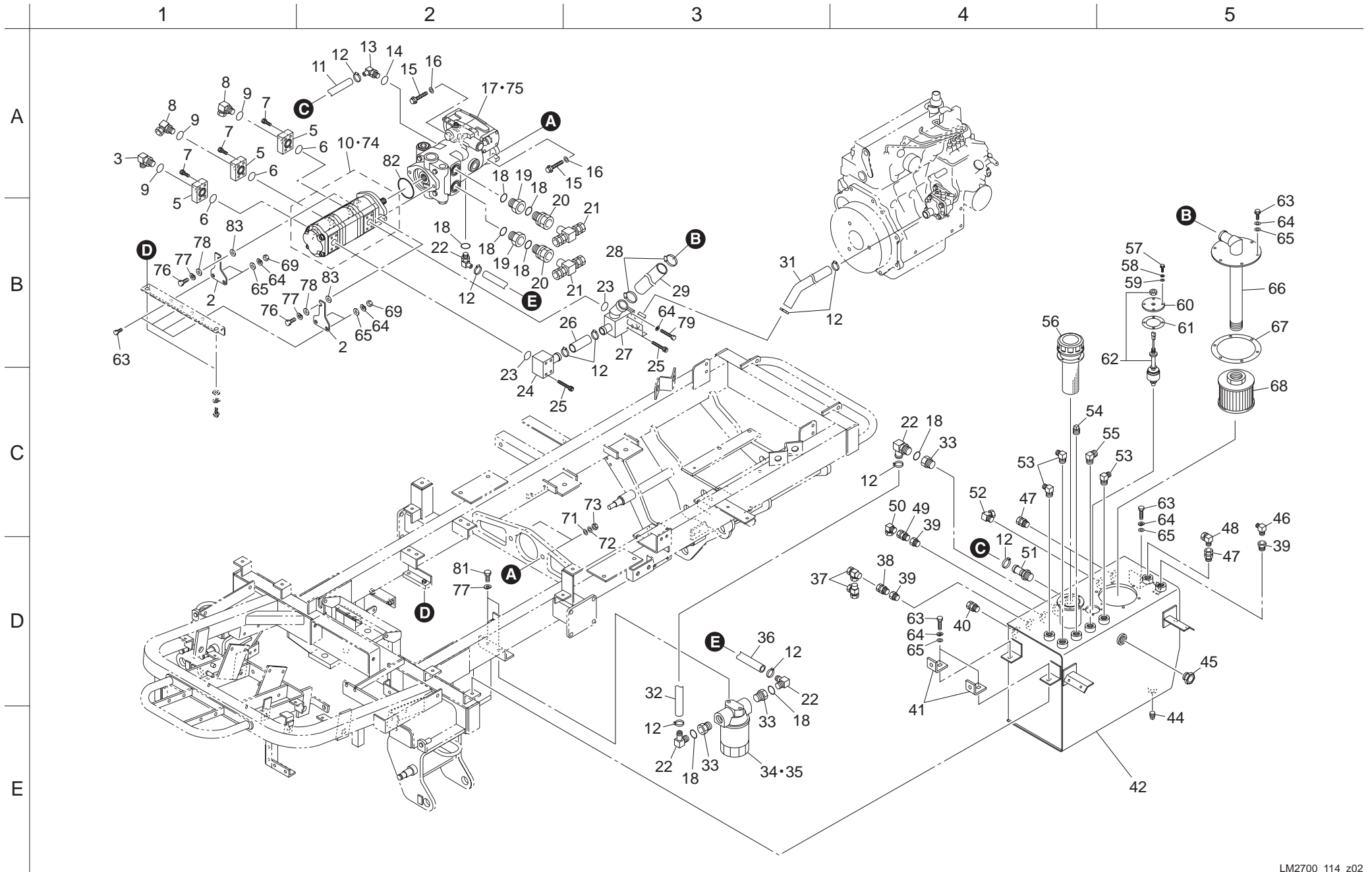

Cat No.	Code No.	Part name	Qty	Remark	SN of application
114-71	K5000120002	WASHER, M12	2		
114-72	K0200120002	WASHER, SPRING M12	2		
114-73	K0100120002	NUT, M12	2		
114-74	Y61-24603	REPAIR KIT	1		
114-75	Y72400-908	SEAL KIT, PISTON PUMP 72400	1		
114-76	K0069000221	BOLT, 3/8-16 UNC 38.1	2		
114-77	K0200100002	WASHER, SPRING M10	4		
114-78	K5000100002	WASHER, M10	4		
114-79	K0000080602	BOLT, M8-60	1		
114-80					
114-81	K0000100202	BOLT, M10-20	2		
114-82	K0887000420	O-RING, AS568-042	1		
114-83	K5073210242	WASHER, SPHC 3.2-10-24	2		

Cat No.	Code No.	Part name	Qty	Remark	SN of application

115. Hydraulic section B

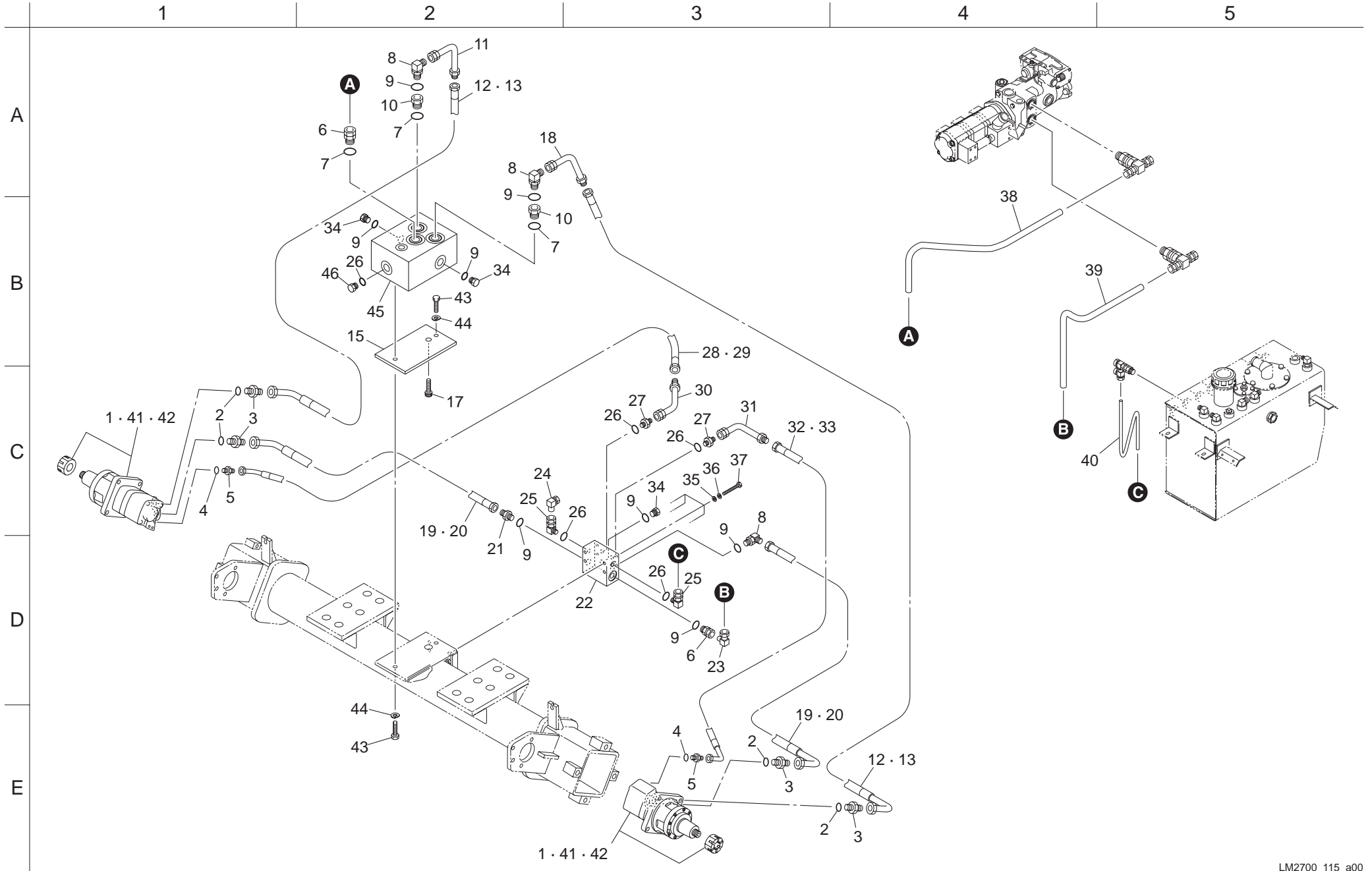

Cat No.	Code No.	Part name	Qty	Remark	SN of application	Cat No.	Code No.	Part name	Qty	Remark	SN of application
115-1	K3291000180	MOTOR, WHEEL 4-330BBAS-F9183	2			115-36	K0200080002	WASHER, SPRING M8	4		
115-2	K0887009120	O-RING, AS568-912	4			115-37	K0000080702	BOLT, M8-70	4		
115-3	K3008000382-Y	CONNECTOR, WITH O-RING 1	4			115-38	LM2700-0824Z2-Y	PIPE, PISTON PUMP C	1		
115-4	K0887009040	O-RING, AS568-904	2			115-39	LM2700-0825Z2-Y	PIPE, PISTON PUMP D	1		
115-5	K3008000342-Y	CONNECTOR, WITH O-RING 1096-6	2			115-40	LM2700-0846Z2-Y	PIPE, FRONT WHEEL MANIFOLD DRAIN	1		
115-6	K3026325121-Y	CONNECTOR, KCO 25-060E	2			115-41	Y61234S	SEAL KIT, WHEEL MOTOR 4-330B/490BBAS (REAR)	2		
115-7	K0881024000	O-RING, P24B	3			115-42	YAE0325A	SEAL KIT, WHEEL MOTOR 4-330BBAS/490BBAS (SHAFT)	2		
115-8	K3008000042-Y	ADAPTOR, 90 DEG 1086-12	3			115-43	K0000100302	BOLT, M10-30	2		
115a-9	K0881018000	O-RING, P18B	8			115-44	K0200100002	WASHER, SPRING M10	2		
115-10	K3029000312-Y	BUSHING, PF1/2*PF3/4	2			115a-45	LM2700-4901Z2-Y	MANIFOLD, B	1		
115-11	K3025069082-Y	ADAPTOR, FOR PIPE 069-08	1			115a-46	K1420000222-Y	PLUG, W/ O-RING 215-PF1/4	1		
115-12	K3106430710	HOSE, WP245-12-3-710	2			115a-47					
115-13	K3191006100	TUBE, SPIRAL SP-15 610	2								
115a-14											
115-15	LM2700-0831ZD	MOUNT, DIFF LOCK VALVE	1								
115-16											
115-17	K0024100151	BOLT, WITH HEX. HOLE M10-15	1								
115-18	K302506L082-Y	ADAPTOR, FOR PIPE 06L-08	1								
115-19	K3106430610	HOSE, WP245-12-3-610	2								
115-20	K3191005100	TUBE, SPIRAL SP-15 510	2								
115-21	K3009000092-Y	ADAPTOR, PT1/2*PF1/2	1								
115-22	LM2700-0821Z2-Y	MANIFOLD	1								
115-23	K3027125001-Y	ELBOW, KLC 25-000E	1								
115-24	K3027110001-Y	ELBOW, KLC 10-000E	1								
115-25	K3026410041-Y	NIPPLE, KLO 10-020KNNT	2								
115a-26	K0881011000	O-RING, P11B	5								
115-27	K3008000232-Y	CONNECTOR, WITH O-RING PF1/4 X PF1/4	2								
115-28	K3101220740	HOSE, WP70-6-2-740	1								
115-29	K3190006400	TUBE, SPIRAL SP-12 640	1								
115-30	K3025064042-Y	ADAPTOR, FOR PIPE 064-04	1								
115-31	K3025069042-Y	ADAPTOR, FOR PIPE 069-04	1								
115-32	K3101220690	HOSE, WP70-6-2-690	1								
115-33	K3190005900	TUBE, SPIRAL SP-12 590	1								
115a-34	K1420000232-Y	PLUG, W/ O-RING WITH HEX. HOLE 215-PF1/2	3								
115-35	K5000080002	WASHER, M8	4								

116. Hydraulic section C

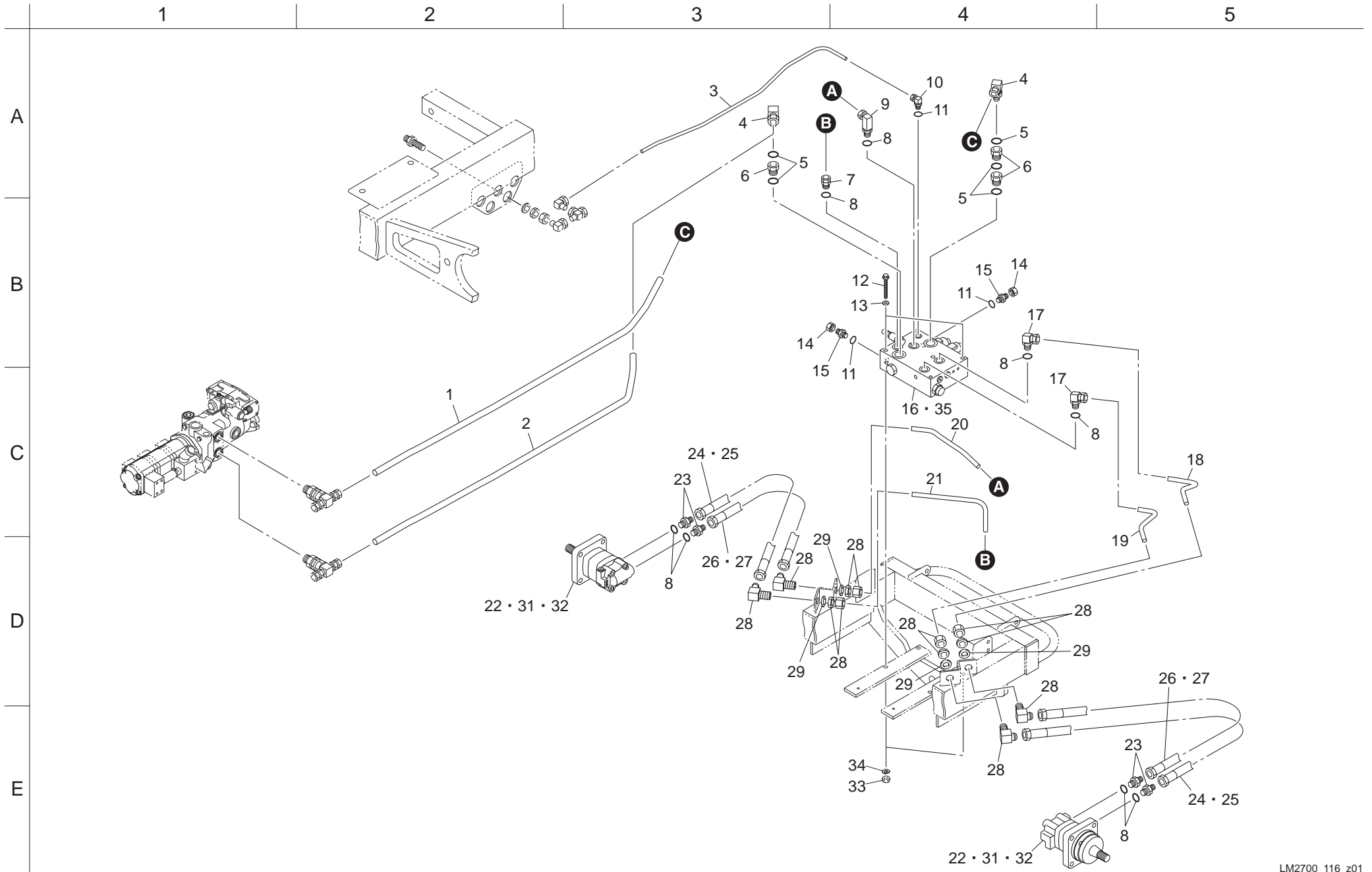

Cat No.	Code No.	Part name	Qty	Remark	SN of application	Cat No.	Code No.	Part name	Qty	Remark	SN of application
116-1	LM2700-0822Z2-Y	PIPE, PISTON PUMP A	1								
116-2	LM2700-0823Z2-Y	PIPE, PISTON PUMP B	1								
116-3	LM2700-0836Z2-Y	PIPE, V5260 DRAIN	1								
116-4	K3026425121-Y	NIPPLE, KLO 25-060E	2								
116-5	K0881024000	O-RING, P24B	5								
116-6	K3008000662-Y	CONNECTOR, WITH O-RING 1110-19-19	3								
116-7	K3026316081-Y	CONNECTOR, KCO 16-040E	1								
116-8	K0881018000	O-RING, P18B	8								
116-9	K3028416081-Y	ELBOW, KLG 16-040E	1								
116-10	K3026410041-Y	NIPPLE, KLO 10-020E	1								
116-11	K0881011000	O-RING, P11B	3								
116-12	K0000101002	BOLT, M10-100	2								
116-13	K5000100002	WASHER, M10	2								
116-14	K3008000482-Y	CAP, TAPPED FEMALE PF1/4	2								
116-15	K3008000232-Y	CONNECTOR, WITH O-RING PF1/4 X PF1/4	2								
116-16	K3313000290	VALVE COMP, SOLENOID V4205	1								
116-17	K3026416081-Y	NIPPLE, KLO 16-040E	2								
116-18	LM2700-0826Z2-Y	PIPE, REAR WHEEL A	1								
116-19	LM2700-0827Z2-Y	PIPE, REAR WHEEL B	1								
116-20	LM2700-0829Z2-Y	PIPE, REAR WHEEL D	1								
116-21	LM2700-0828Z2-Y	PIPE, REAR WHEEL C	1								
116-22	K3291000130	MOTOR, ORBIT 2-160BS4S-E341	2								
116-23	K3009000092-Y	ADAPTOR, PT1/2*PF1/2	4								
116-24	K3106410850	HOSE, WP245-12-1-850	2								
116-25	K3191007500	TUBE, SPIRAL SP-15 750	2								
116-26	K3106410800	HOSE, WP245-12-1-800	2								
116-27	K3191007000	TUBE, SPIRAL SP-15 700	2								
116-28	K3028716081-Y	UNION, KLH 16-040E	4								
116-29	K0214240001	WASHER, DISK SPRING L M24-2	4								
116-30											
116-31	Y61091S	SEAL KIT, 2000 ORBIT MOTOR (SHAFT)	2								
116-32	Y61090S	SEAL KIT, 2000 ORBIT MOTOR (REAR)	2								
116-33	K0100100002	NUT, M10	2								
116-34	K0200100002	WASHER, SPRING M10	2								
116-35	YSK08-3N-MM	SEAL KIT, FOR VALVE, SOLENOID V4205	1								

117. Hydraulic section D

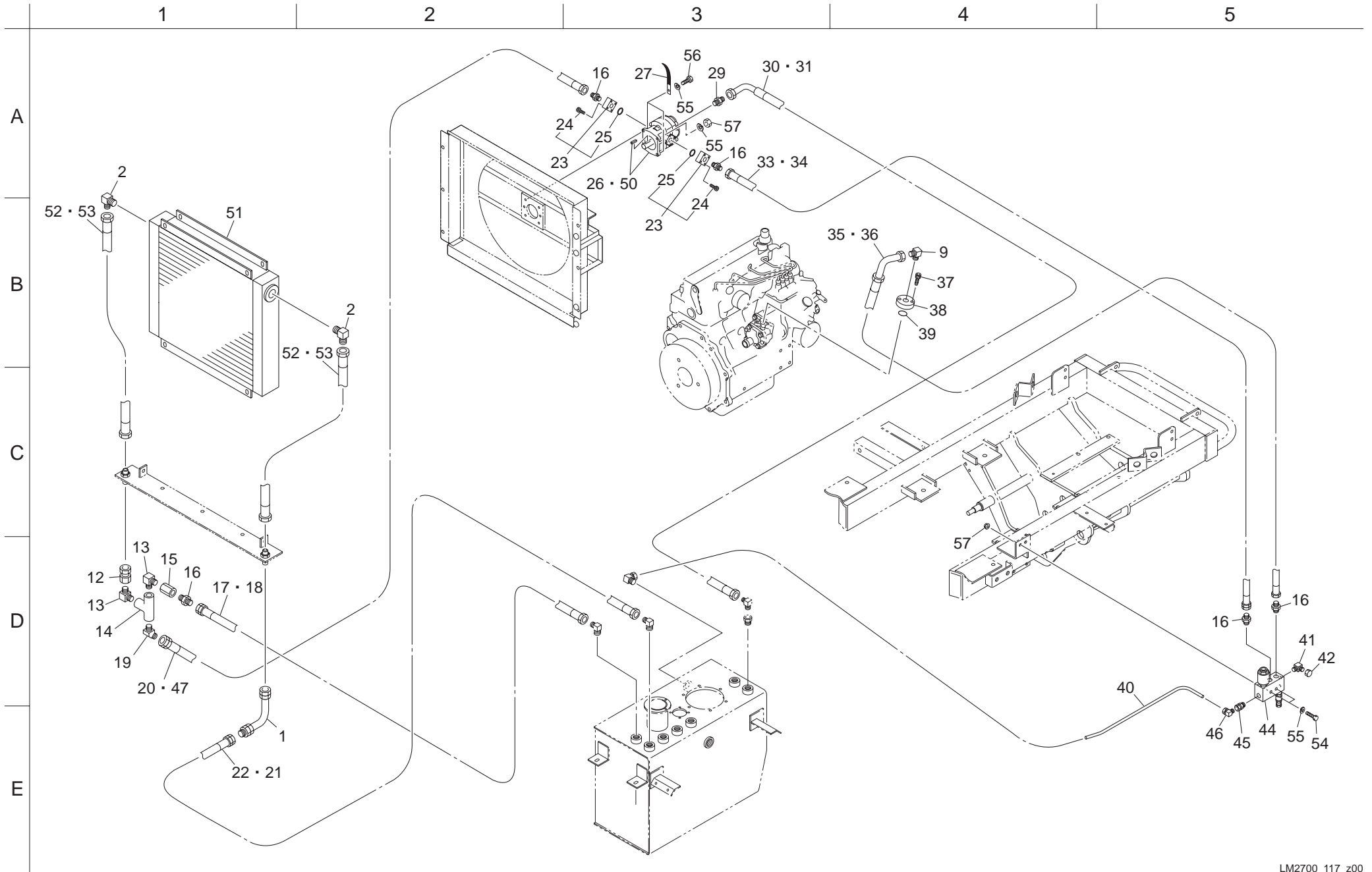

Cat No.	Code No.	Part name	Qty	Remark	SN of application
117-1	K3025069062-Y	ADAPTOR, FOR PIPE 069-06	1		
117-2	K3006000022-Y	ELBOW, ODD SIZED PT1/2*PF3/8	2		
117-3					
117-4					
117-5					
117-6					
117-7					
117-8					
117-9	K3001090002-Y	ELBOW, 90 DEG 1033-9	2		
117-10					
117-11					
117-12	K3008000712-Y	CONNECTOR, SWIVEL 06	1		
117-13	K3006000072-Y	ELBOW, PT3/8	2		
117-14	K3021060002-Y	TEE, TEF PT3/8	1		
117-15	K3340000030	VALVE, CHECK 03-100	1		
117-16	K3000090002-Y	ADAPTOR, 1013-9	5		
117-17	K3100311050	HOSE, WP35-9-1-1050	1		
117-18	K3191009500	TUBE, SPIRAL SP-15 950	1		
117-19	K3003090002-Y	ELBOW, 45 DEG 1035-9	1		
117-20	K3100310700	HOSE, WP35-9-1-700	1		
117-21	K3191008000	TUBE, SPIRAL SP-15 800	1		
117-22	K3100310900	HOSE, WP35-9-1-900	1		
117-23	K3281000010	FLANGE, PORT 14.8 D	2		
117-24	K0024060301	BOLT, WITH HEX. HOLE M6-30	2		
117-25	K0881022000	O-RING, P22B	2		
117-26	K3280000240	MOTOR, GEAR MA7AD661	1		
117-27	K4281000020	CLAMP, HARNESS 8.5 80	1		
117-28					
117-29	K3007000032-Y	ADAPTOR, ODD SIZED PT1/8*PF1/4	1		
117-30	K3101231520	HOSE, WP70-6-3-1520	1		
117-31	K3190014200	TUBE, SPIRAL SP-12 1420	1		
117-32					
117-33	K3101310550	HOSE, WP70-9-1-550	1		
117-34	K3191004500	TUBE, SPIRAL SP-15 450	1		
117-35	K3101330360	HOSE, WP70-9-3-360	1		

Cat No.	Code No.	Part name	Qty	Remark	SN of application
117-36	K3191002600	TUBE, SPIRAL SP-15 260	1		
117-37	K0024080251	BOLT, WITH HEX. HOLE M8-25	2		
117-38	LM2700-0811Z2-Y	FLANGE, PUMP	1		
117-39	K0881020000	O-RING, P20B	1		
117-40	LM2700-0851Z2-Y	PIPE, V4127A TANK	1		
117-41	K3006000152-Y	ELBOW, ODD SIZED PT1/8*PF1/4	1		
117-42	K3008000482-Y	CAP, TAPPED FEMALE PF1/4	1		
117-43					
117-44	K3313000250	VALVE, SOLENOID V4209	1		
117-45	K3026612061-Y	CONNECTOR, KCT 12-030E	1		
117-46	K3027112001-Y	ELBOW, KLC 12-000E	1		
117-47	K3191006000	TUBE, SPIRAL SP-15 600	1		
117-48					
117-49					
117-50	Y61-25070	SEAL KIT, MA GEAR MOTOR 661	1		
117-51	LM2700-3839Z0	OIL COOLER ASSY	1		
117-52	K3100310380	HOSE, WP35-9-1-380	2		
117-53	K3191002800	TUBE, SPIRAL SP-15 280	2		
117-54	K0000080502	BOLT, M8-50	2		
117-55	K0200080002	WASHER, SPRING M8	6		
117-56	K0000080202	BOLT, M8-20	2		
117-57	K0100080002	NUT, M8	4		

118. Hydraulic section E

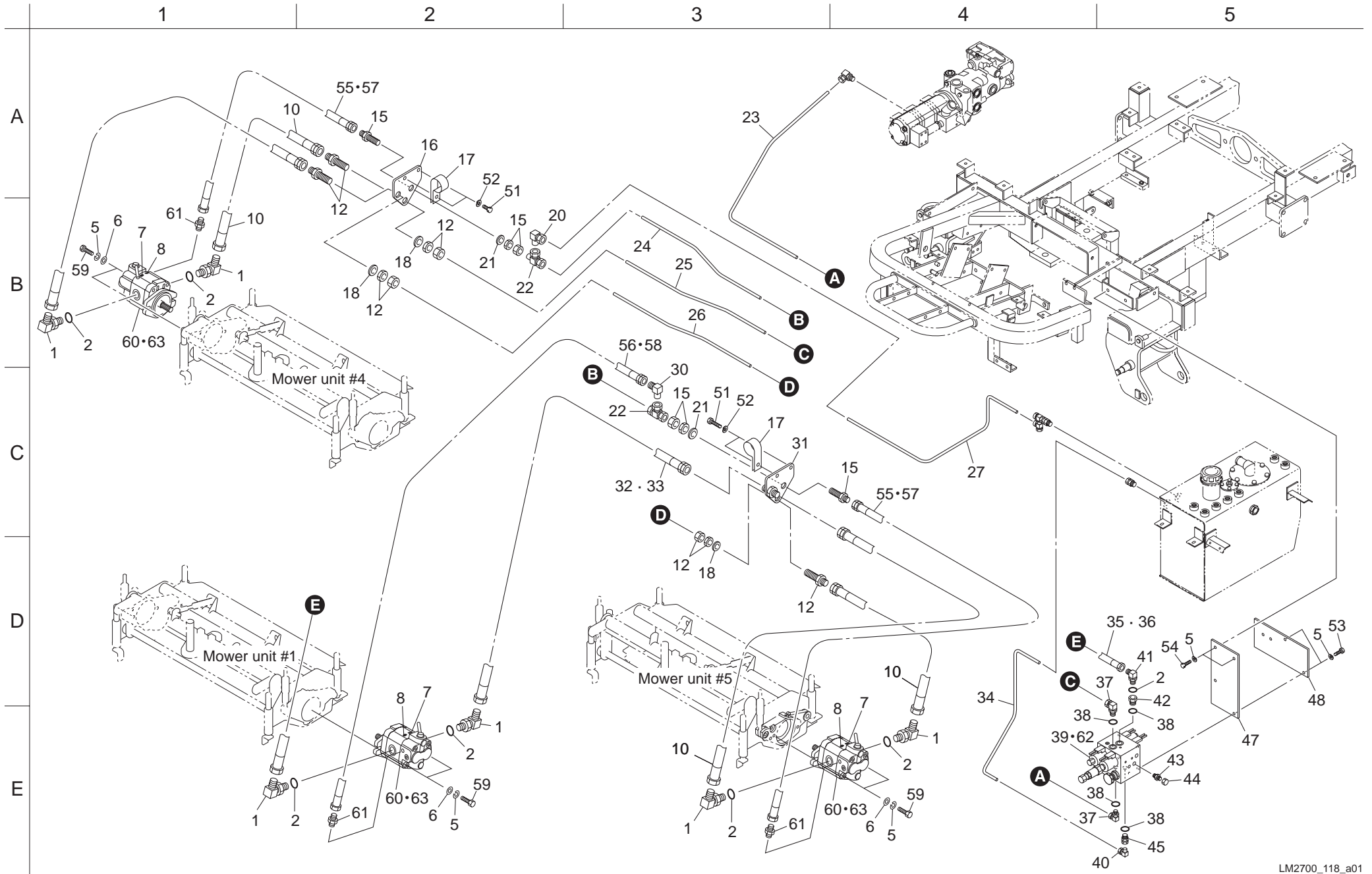

Cat No.	Code No.	Part name	Qty	Remark	SN of application
118-1	K3008000352-Y	ELBOW, 90 DEG. ODD SIZED PF3/8 PF1/2	6		
118-2	K0881018000	O-RING, P18B	7		
118-3					
118-4					
118-5	K0200100002	WASHER, SPRING M10	10		
118-6	K5000100002	WASHER, M10	6		
118-7	K4203001300	DECAL, REEL ROTATION	3		
118-8	K4203001310	DECAL, REEL STOP	3		
118-9					
118a-10	LM2700-3841A0	HOSE, WP140-9-1-1400	4		
118a-11					
118-12	K3026912061-Y	UNION, KUE 12-030E	3		
118-13					
118-14					
118-15	K3026910041-Y	UNION, KUE 10-020E	2		
118-16	LM2700-0833Z2	BRACKET, HOSE #4 MOWER	1		
118-17	K4270050080	CLIP, HARNESS 50 M8	2		
118-18	K0214180001	WASHER, DISK SPRING L M18-2	3		
118-19					
118-20	K3027110001-Y	ELBOW, KLC 10-000E	1		
118-21	K0214160001	WASHER, DISK SPRING L M16-2	2		
118-22	K3027210001-Y	TEE, KTC 10-000E	2		
118-23	LM2700-0854Z2-Y	PIPE, V5259 PUMP	1		
118-24	LM2700-0845Z2-Y	PIPE, #5 MOTOR DRAIN	1		
118-25	LM2700-0857Z2-Y	PIPE, #4 MOTOR OUT	1		
118-26	LM2700-0859Z2-Y	PIPE, #5 MOTOR IN	1		
118-27	LM2700-0844Z2-Y	PIPE, #4 MOTOR DRAIN	1		
118-28					
118-29					
118-30	K3028510041-Y	ELBOW, FOR HOSE HLD 10-20E	1		
118-31	LM2700-0832Z2-Y	BRACKET, HOSE #5 MOWER	1		
118-32	K3103321970	HOSE, WP140-9-2-1970	1		
118-33	K3191018700	TUBE, SPIRAL SP-15 1870	1		
118-34	LM2700-0858Z2-Y	PIPE, V5259 TANK	1		
118-35	K3103311840	HOSE, WP140-9-1-1840	1		

Cat No.	Code No.	Part name	Qty	Remark	SN of application
118-36	K3191017400	TUBE, SPIRAL SP-15 1740	1		
118-37	K3026412061-Y	NIPPLE, KLO 12-030E	2		
118-38	K0881014000	O-RING, P14B	4		
118-39	K3313000280	VALVE COMP, SOLENOID V5259A	1		
118-40	K3027112001-Y	ELBOW, KLC 12-000E	1		
118-41	K3008000032-Y	ADAPTOR, 90 DEG 1086-9	1		
118-42	K3029000282-Y	BUSHING, PF3/8*PF3/8	1		
118-43	K3000060002-Y	ADAPTOR, 1013-6	1		
118-44	K3008000482-Y	CAP, TAPPED FEMALE PF1/4	1		
118-45	K3026312061-Y	CONNECTOR, KCO 12-030E	1		
118-46					
118-47	LM2700-0814ZD	BRACKET, VALVE #1 #4 #5 MOWER	1		
118-48	LM2700-0866ZD	BRACKET, MANIFOLD	1		
118-49					
118-50					
118-51	K0000080202	BOLT, M8-20	4		
118-52	K0200080002	WASHER, SPRING M8	4		
118-53	K0000100252	BOLT, M10-25	2		
118-54	K0000100302	BOLT, M10-30	2		
118-55	K3101211420	HOSE, WP70-6-1-1420	2		
118-56	K3101221830	HOSE, WP70-6-1-1830	1		
118-57	K3190013200	TUBE, SPIRAL SP-12 1320	2		
118-58	K3190017300	TUBE, SPIRAL SP-12 1730	1		
118-59	K0008100302	BOLT, SMALL M10-30	6		
118-60	K3282000060	MOTOR, GEAR PLM20.16	3		10864-
118-61	K3008000232-Y	CONNECTOR, WITH O-RING PF1/4 X PF1/4	3		
118-62	Y889625	SEAL KIT, FOR VALVE, SOLENOID V5259A	1		
118-63	Y62029050	SEAL KIT, PLM20-01S9R	3		10864-

119. Hydraulic section F

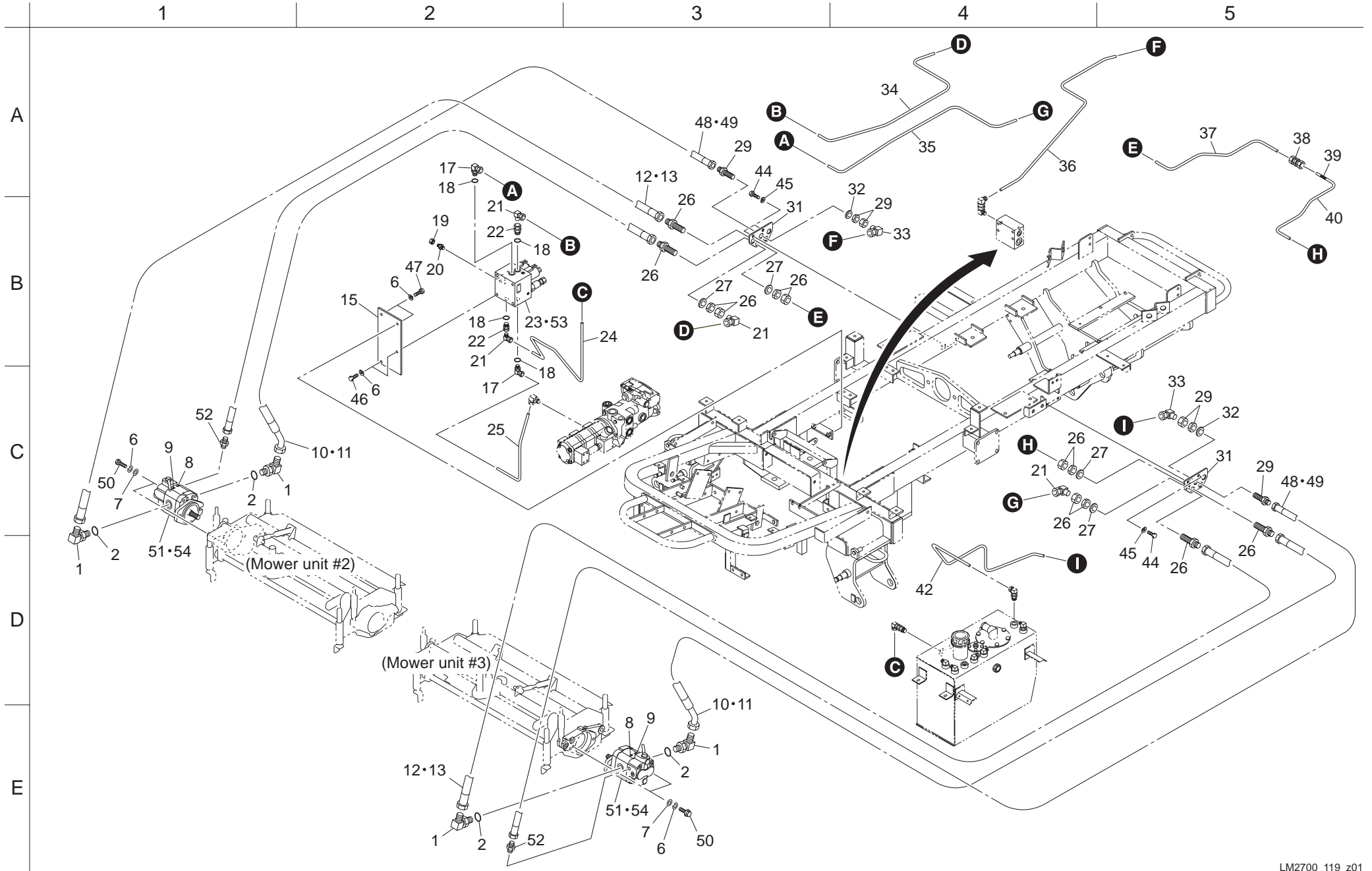

Cat No.	Code No.	Part name	Qty	Remark	SN of application	Cat No.	Code No.	Part name	Qty	Remark	SN of application
119-1	K3008000352-Y	ELBOW, 90 DEG. ODD SIZED PF3/8 PF1/2	4			119-36	LM2700-0841Z2-Y	PIPE, #2 MOTOR DRAIN	1		
119-2	K0881018000	O-RING, P18B	4			119-37	LM2700-0862Z2-Y	PIPE, #2 MOTOR IN	1		
119-3						119-38	K3028612001-Y	UNION, KUA 12-000E	1		
119-4						119-39	K3186000500	HOSE, VINYL 10-50	1		
119-5						119-40	LM2700-0839Z2-Y	PIPE, #3 MOTOR OUT	1		
119-6	K0200100002	WASHER, SPRING M10	8			119-41					
119-7	K5000100002	WASHER, M10	4			119-42	LM2700-0843Z2-Y	PIPE, #3 MOTOR DRAIN	1		
119-8	K4203001300	DECAL, REEL ROTATION	2			119-43					
119-9	K4203001310	DECAL, REEL STOP	2			119-44	K0000080202	BOLT, M8-20	4		
119-10	K3103321020	HOSE, WP140-9-2-1020	2			119-45	K0200080002	WASHER, SPRING M8	4		
119-11	K3191009200	TUBE, SPIRAL SP-15 920	2			119-46	K0000100202	BOLT, M10-20	2		
119-12	K3103311000	HOSE, WP140-9-1-1000	2			119-47	K0000100302	BOLT, M10-30	2		
119-13	K3191009000	TUBE, SPIRAL SP-15 900	2			119-48	K3190008700	TUBE, SPIRAL SP-12 870	2		
119-14						119-49	K3101210970	HOSE, WP70-6-1-970	2		
119-15	LM2700-0813ZD	BRACKET, VALVE #2 #3 MOWER	1			119-50	K0008100302	BOLT, SMALL M10-30	4		
119-16						119-51	K3282000060	MOTOR, GEAR PLM20.16	2		10864-
119-17	K3026412061-Y	NIPPLE, KLO 12-030E	2			119-52	K3008000232-Y	CONNECTOR, WITH O-RING PF1/4 X PF1/4	2		
119-18	K0881014000	O-RING, P14B	4			119-53	Y889625	SEAL KIT, FOR VALVE, SOLENOID V5259A	1		
119-19	K3008000482-Y	CAP, TAPPED FEMALE PF1/4	1			119-54	Y62029050	SEAL KIT, PLM20-01S9R	2		10864-
119-20	K3000060002-Y	ADAPTOR, 1013-6	1								
119-21	K3027112001-Y	ELBOW, KLC 12-000E	4								
119-22	K3026312061-Y	CONNECTOR, KCO 12-030E	2								
119-23	K3313000280	VALVE COMP, SOLENOID V5259A	1								
119-24	LM2700-3834Z2-Y	PIPE, V5259A TANK	1								
119-25	LM2700-3836Z2-Y	PIPE, V5259A PUMP	1								
119-26	K3026912061-Y	UNION, KUE 12-030E	4								
119-27	K0214180001	WASHER, DISK SPRING L M18-2	4								
119-28											
119-29	K3026910041-Y	UNION, KUE 10-020E	2								
119-30											
119-31	LM2700-0812ZD	BRACKET, HOSE #2 #3 MOWER	2								
119-32	K0214160001	WASHER, DISK SPRING L M16-2	2								
119-33	K3027110001-Y	ELBOW, KLC 10-000E	2								
119-34	LM2700-3835Z2-Y	PIPE, #2 MOTOR OUT	1								
119-35	LM2700-3837Z2-Y	PIPE, #2 MOTOR IN	1								

120. Hydraulic section G

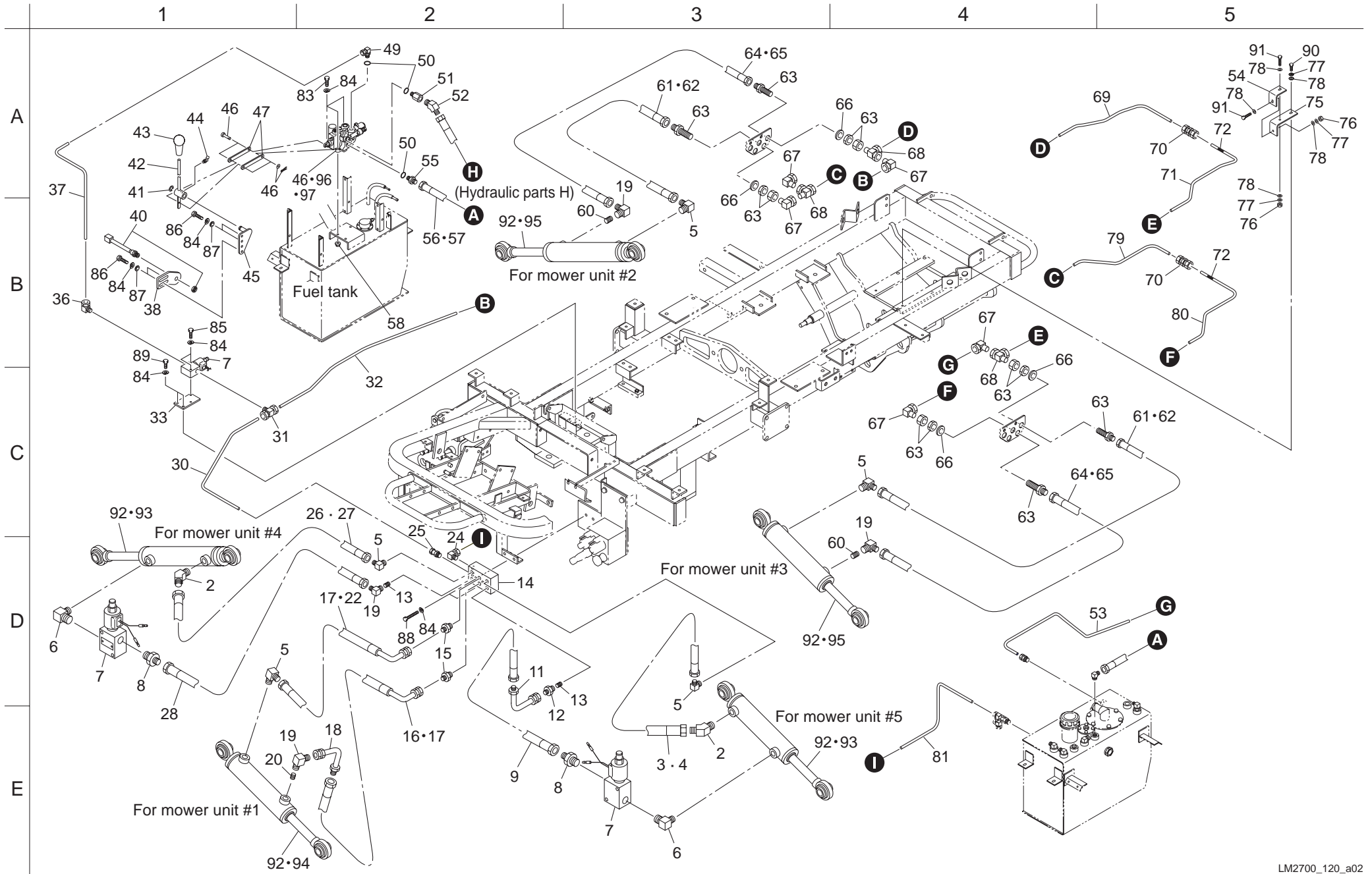

Cat No.	Code No.	Part name	Qty	Remark	SN of application
120-1					
120-2	K3003060002-Y	ELBOW, 45 DEG 1035-6	2		
120-3	K3101210650	HOSE, WP70-6-1-650	1		
120-4	K3190005500	TUBE, SPIRAL SP-12 550	1		
120-5	K3001060002-Y	ELBOW, 90 DEG 1033-6	5		
120-6	K3006000032-Y	ELBOW, ODD SIZED PT1/4*PT3/8	2		
120-7	K3313000040	VALVE, SOLENOID V4029	3		
120-8	K3009000042-Y	ADAPTOR, PF1/4*PT3/8	2		
120a-9	LM2700-3842A0	HOSE, WP105-6-2-800	1		
120a-10					
120-11	K302506L042-Y	ADAPTOR, FOR PIPE 06L-04	1		
120-12	K3009000272-Y	ADAPTOR, 1013-6M6	1		
120-13	K0023000051-Y	SETSCREW, M6-6-1.2	2		
120-14	LM2700-0834Z2-Y	MANIFOLD, CYLINDER	1		
120-15	K3000060002-Y	ADAPTOR, 1013-6	2		
120-16	K3102230600	HOSE, WP105-6-3-600	1		
120-17	K3190005000	TUBE, SPIRAL SP-12 500	2		
120-18	K3025069042-Y	ADAPTOR, FOR PIPE 069-04	1		
120-19	K3029000252-Y	ELBOW, 90 DEG 1033-6M6	4		
120-20	K0023000061-Y	SETSCREW, M6-6-1.6	1		
120-21					
120-22	K3101230600	HOSE, WP70-6-3-600	1		
120-23					
120-24	K3028010041-Y	ELBOW, KLN 10-020E	1		
120-25	K3026610041-Y	CONNECTOR, KCT 10-020E	1		
120-26	K3101211040	HOSE, WP70-6-1-1040	1		
120-27	K3190009400	TUBE, SPIRAL SP-12 940	1		
120a-28	LM2700-3843A0	HOSE, WP105-6-2-1100	1		
120a-29					
120-30	LM2700-0847Z2-Y	PIPE, #1 #4 #5 CYLINDER	1		
120-31	K3028210061-Y	TEE, KTN 10-030E	1		
120-32	LM2700-0840Z2-Y	PIPE, #2 CYLINDER	1		
120-33	LM2700-0865ZD	BRACKET, VALVE	1		
120-34					
120-35					

Cat No.	Code No.	Part name	Qty	Remark	SN of application
120-36	K3028012061-Y	ELBOW, KLN 12-030E	1		
120-37	LM2700-0856Z2-Y	PIPE, CYLINDER	1		
120-38	LM2700-0625ZD	BRACKET, SWITCH	1		
120-39					
120-40	LM2700-0557Z0	SENSOR, PROXIMITY E2E-X5E	1		
120-41	K0400012002	RING, RETAINING E M12	1		
120-42	LM2700-0874Z2	LEVER	1		
120-43	K1300000050	GRIP, RUBBER RED 9-35.5	1		
120-44	K1440000030	GREASE NIPPLE, B	1		
120-45	LM2700-0873Z2	BRACKET, LEVER	1		
120-46	K3300000190	VALVE, MULTIPLE SV3-1191	1		
120-47	LM2700-0875Z2	BRACKET, VALVE	2		
120-48					
120-49	K3026412061-Y	NIPPLE, KLO 12-030E	1		
120-50	K0881018000	O-RING, P18B	3		
120-51	K3029000072-Y	BUSHING, PF3/8*PT3/8	1		
120-52	K3003090002-Y	ELBOW, 45 DEG 1035-9	1		
120-53	LM2700-0842Z2-Y	PIPE, #3 CYLINDER DRAIN	1		
120-54	LM2700-0864ZD	CLAMPER, PIPE B	1		
120-55	K3009000172-Y	ADAPTOR, PF3/8*PF1/2	1		
120-56	K3100421050	HOSE, WP35-12-2-1050	1		
120-57	K3191009500	TUBE, SPIRAL SP-15 950	1		
120-58	K0100080002	NUT, M8	3		
120-59					
120-60	K0023000011-Y	SETSCREW, M6-6-1	2		
120-61	K3102220460	HOSE, WP105-6-2-460	2		
120-62	K3190003600	TUBE, SPIRAL SP-12 360	2		
120-63	K3026910041-Y	UNION, KUE 10-020E	4		
120-64	K3102230430	HOSE, WP105-6-3-430	2		
120-65	K3190003300	TUBE, SPIRAL SP-12 330	2		
120-66	K0214160001	WASHER, DISK SPRING L M16-2	4		
120-67	K3027110001-Y	ELBOW, KLC 10-000E	5		
120-68	K3027210001-Y	TEE, KTC 10-000E	3		
120-69	LM2700-0837Z2-Y	PIPE, #2 #3 CYLINDER DRAIN	1		
120-70	K3028610001-Y	UNION, KUA 10-000E	2		

120. Hydraulic section G

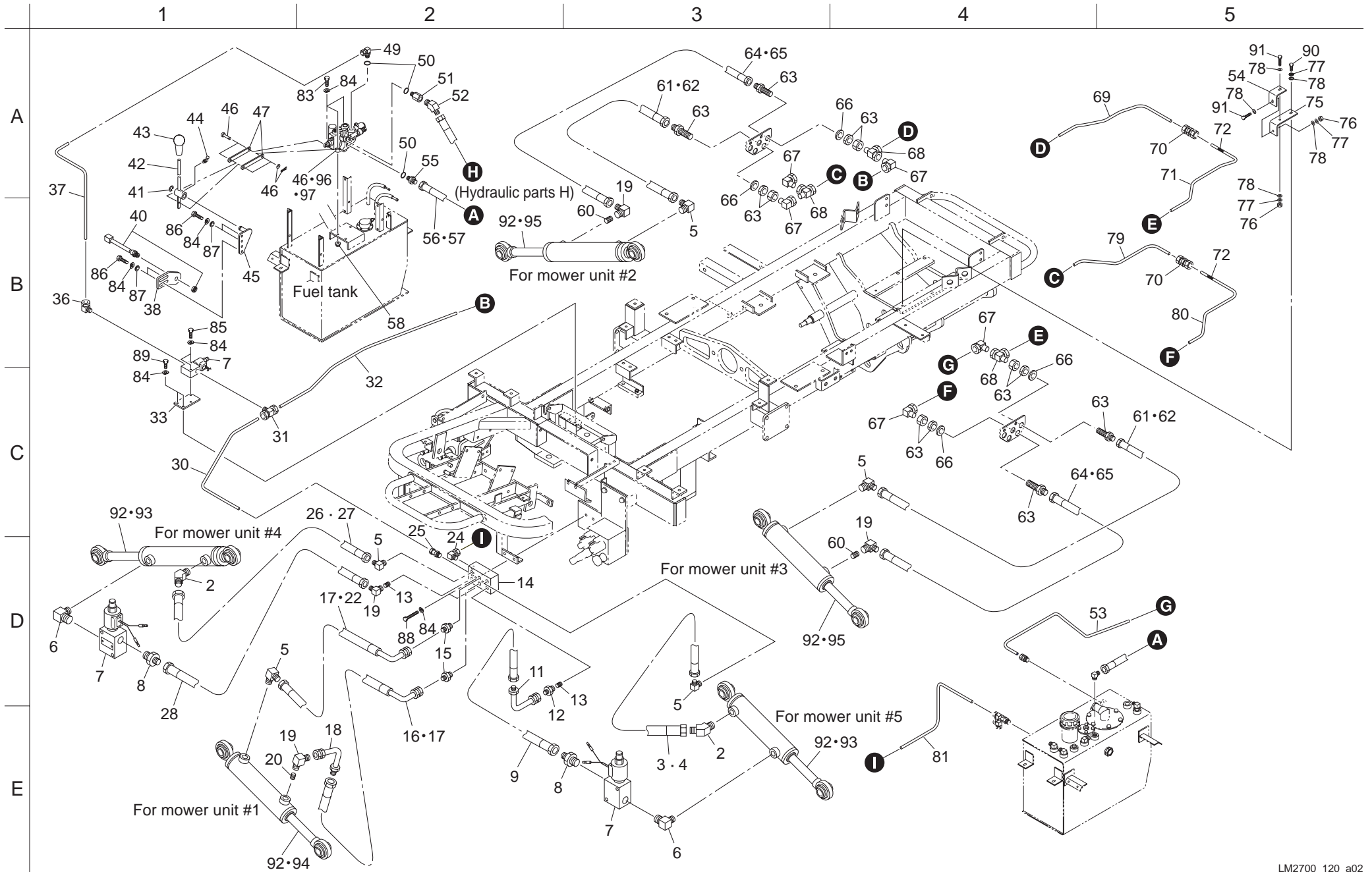

Cat No.	Code No.	Part name	Qty	Remark	SN of application	Cat No.	Code No.	Part name	Qty	Remark	SN of application
120-71	LM2700-0861Z2-Y	PIPE, #3 CYLINDER DRAIN	1								
120-72	K3186000500	HOSE, VINYL 10-50	2								
120-73											
120-74											
120-75	LM2700-0863ZD	CLAMPER, PIPE A	1								
120-76	K0100060002	NUT, M6	2								
120-77	K0200060002	WASHER, SPRING M6	2								
120-78	K5000060002	WASHER, M6	5								
120-79	LM2700-0838Z2-Y	PIPE, #2 #3 CYLINDER	1								
120-80	LM2700-0860Z2-Y	PIPE, #3 CYLINDER	1								
120-81	LM2700-0848A2-Y	PIPE, CYLINDER DRAIN #1, 3, 5	1								
120-82											
120-83	K0000080302	BOLT, M8-30	3								
120-84	K0200080002	WASHER, SPRING M8	13								
120-85	K0000080402	BOLT, M8-40	2								
120-86	K0000080152	BOLT, M8-15	4								
120-87	K5000080002	WASHER, M8	4								
120-88	K0000080502	BOLT, M8-50	2								
120-89	K0000080202	BOLT, M8-20	2								
120-90	K0000060152	BOLT, M6-15	1								
120-91	K0000060402	BOLT, M6-40	2								
120-92	YIS-40A-SK	SEAL KIT, CYLINDER	5								
120-93	K3213000250	CYLINDER, 40-200 387	2								
120-94	K3213000240	CYLINDER, 40-138 363	1								
120-95	K3213000230	CYLINDER, 40-90 307	2								
120-96	YSV3-010-IC27	SEAL KIT (INLET COVER)	1								
120-97	YSV3-010-ISB222	SEAL KIT (ISB BLOCK ASSY)	1								

121. Hydraulic section H

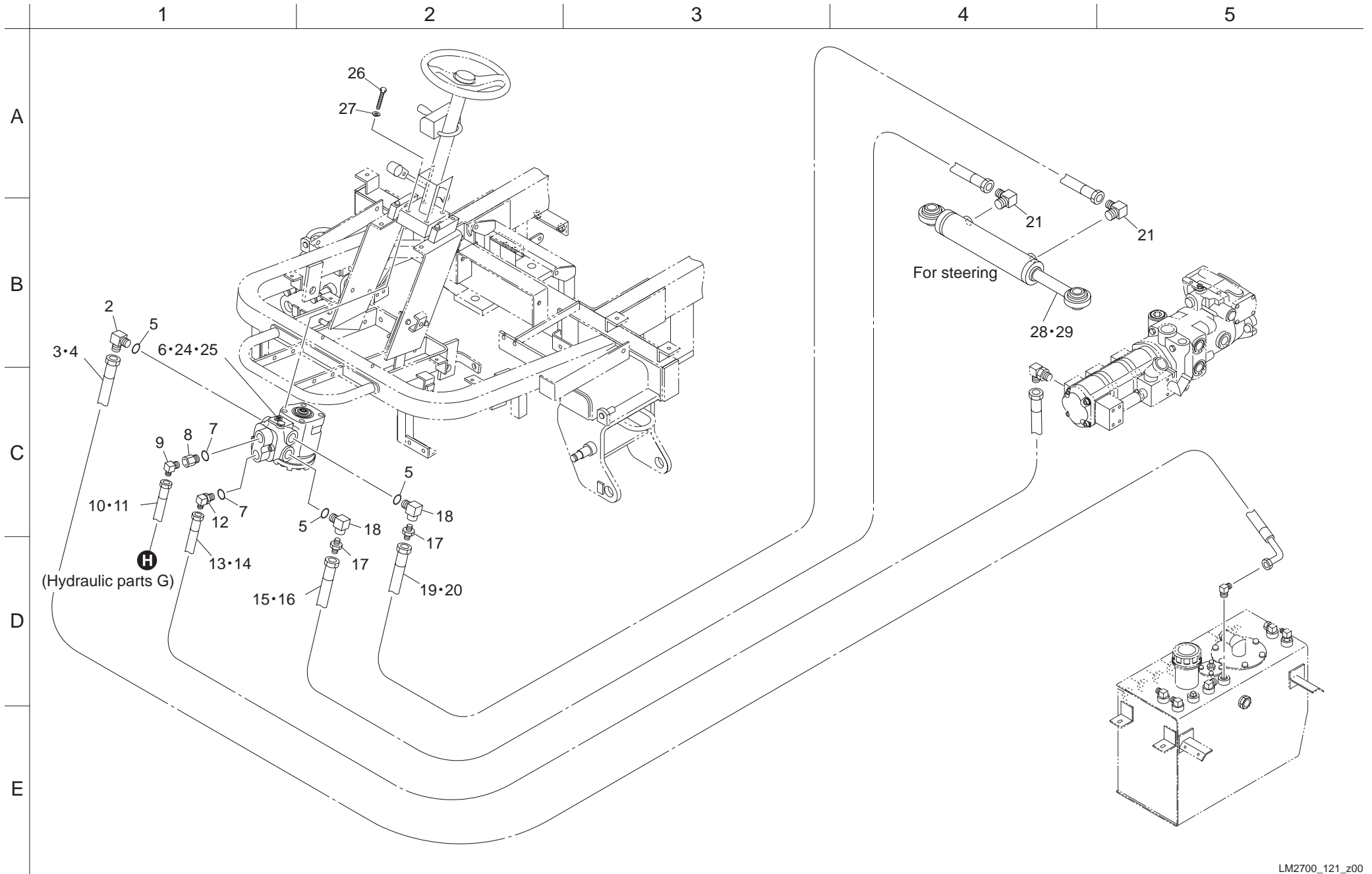

Cat No.	Code No.	Part name	Qty	Remark	SN of application	Cat No.	Code No.	Part name	Qty	Remark	SN of application
121-1											
121-2	K3008000032-Y	ADAPTOR, 90 DEG 1086-9	1								
121-3	K3100331720	HOSE, WP35-9-3-1720	1								
121-4	K3191016200	TUBE, SPIRAL SP-15 1620	1								
121-5	K0881014000	O-RING, P14B	3								
121-6	K3294000120	STEERING CNTL UNIT, ORBITROL LC-D1-E	1								
121-7	K0881018000	O-RING, P18B	2								
121-8	K3029000042-Y	BUSHING, PF1/2*PT3/8	1								
121-9	K3001090002-Y	ELBOW, 90 DEG. 1033-9	1								
121-10	K3102311500	HOSE, WP105-9-1-1500	1								
121-11	K3191014000	TUBE, SPIRAL SP-15 1400	1								
121-12	K3008000352-Y	ELBOW, 90 DEG. ODD SIZED PF3/8 PF1/2	1								
121-13	K3102311100	HOSE, WP105-9-1-1100	1								
121-14	K3191010000	TUBE, SPIRAL SP-15 1000	1								
121-15	K3101213000	HOSE, WP70-6-1-3000	1								
121-16	K3190029000	TUBE, SPIRAL SP-12 2900	1								
121-17	K3000060002-Y	ADAPTOR, 1013-6	2								
121-18	K3008000082-Y	ADAPTOR, 90 DEG PF3/8PT1/4	2								
121-19	K3101213210	HOSE, WP70-6-1-3210	1								
121-20	K3190031100	TUBE, SPIRAL SP-12 3110	1								
121-21	K3001060002-Y	ELBOW, 90 DEG 1033-6	2								
121-22											
121-23											
121-24	YBK0039A	SEAL KIT, ORBITROL LB-D1-A	1								
121-25	YBA0271A	SEAL KIT, ORBITROL UA-B4-D	1								
121-26	K0000100502	BOLT, M10-50	4								
121-27	K0200100002	WASHER, SPRING M10	4								
121-28	YIS-40A-SK	SEAL KIT, CYLINDER	1								
121-29	K3213000190	CYLINDER, 40-187-393	1								

122. 26inch Lift arm front section

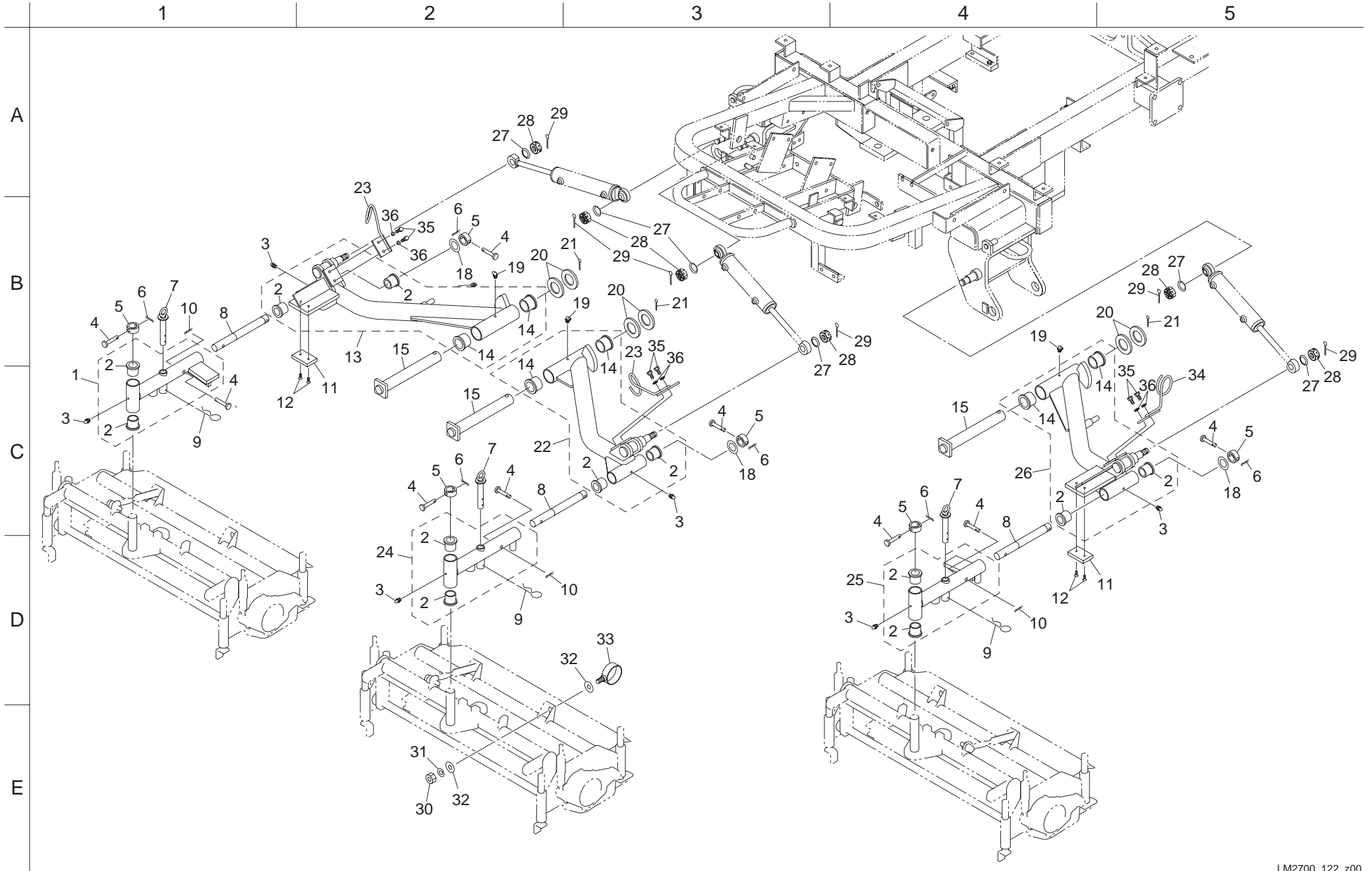

Cat No.	Code No.	Part name	Qty	Remark	SN of application	Cat No.	Code No.	Part name	Qty	Remark	SN of application
122-1	LM2700-0218ZR	JOINT, MOWER #4	1			122-36	K0200080002	WASHER, SPRING M8	6		
122-2	K6010000150	BUSH, FLANGED 25-32-30	12								
122-3	K1440000010	GREASE NIPPLE, A TYPE	6								
122-4	K6031090458	PIN, FLAT HEAD HT M9.6-45.5	9								
122-5	K6215000412	COLLAR, STKM WITH HOLE M25.5-36-16	6								
122-6	K0341000002	PIN, SNAP WITH RETAINER M10	6								
122-7	LM2700-0204A2	PIN, LOCKING	3								
122-8	LM2700-0202Z0	SHAFT	3								
122-9	K0332200008	PIN, SNAP M22	3								
122-10	K0300025202	PIN, COTTER M2.5-20	3								
122-11	K4033000380	RUBBER, PLATE STOPPER	2								
122-12	K0041060152	SCREW, +FLAT HEAD M6-15	4								
122-13	LM2700-0208ZD	ARM, LIFTING #4	1								
122-14	K6010000140	BUSH, FLANGED 30-38-30	6								
122-15	K7147000232	PIN, WITH HOLE M30-197	3								
122-16											
122-17											
122-18	K5011025372	WASHER, SPCC 1-25.4-37	3	for adjustment							
122-19	K1440000020	GREASE NIPPLE, C	3								
122-20	K5012330452	WASHER, SPCC 2.3-30-45	6								
122-21	K0300040502	PIN, COTTER M4-50	3								
122-22	LM2700-0210ZD	ARM, LIFTING #1	1								
122-23	LM2700-0232Z2	GUIDE, HOSE B	2								
122-24	LM2700-0201ZR	CONNECTOR, MOWER	1								
122-25	LM2700-0217ZR	JOINT, MOWER #5	1								
122-26	LM2700-0207ZD	ARM, LIFTING #5	1								
122-27	K0215160001	WASHER, DISK SPRING H M16-2	6								
122-28	K0122160002	NUT, HIGH SLOTTED P1.5 M16	6								
122-29	K0300032402	PIN, COTTER M3.2-40	6								
122-30	K0100120002	NUT, M12	1								
122-31	K0200120002	WASHER, SPRING M12	1								
122-32	K5000120002	WASHER, M12	2								
122-33	LM2700-0231Z2	GUIDE, HOSE A	1								
122-34	LM2700-0234Z2	GUIDE, HOSE D	1								
122-35	K0000080152	BOLT, M8-15	6								

123. 22inch Lift arm front section

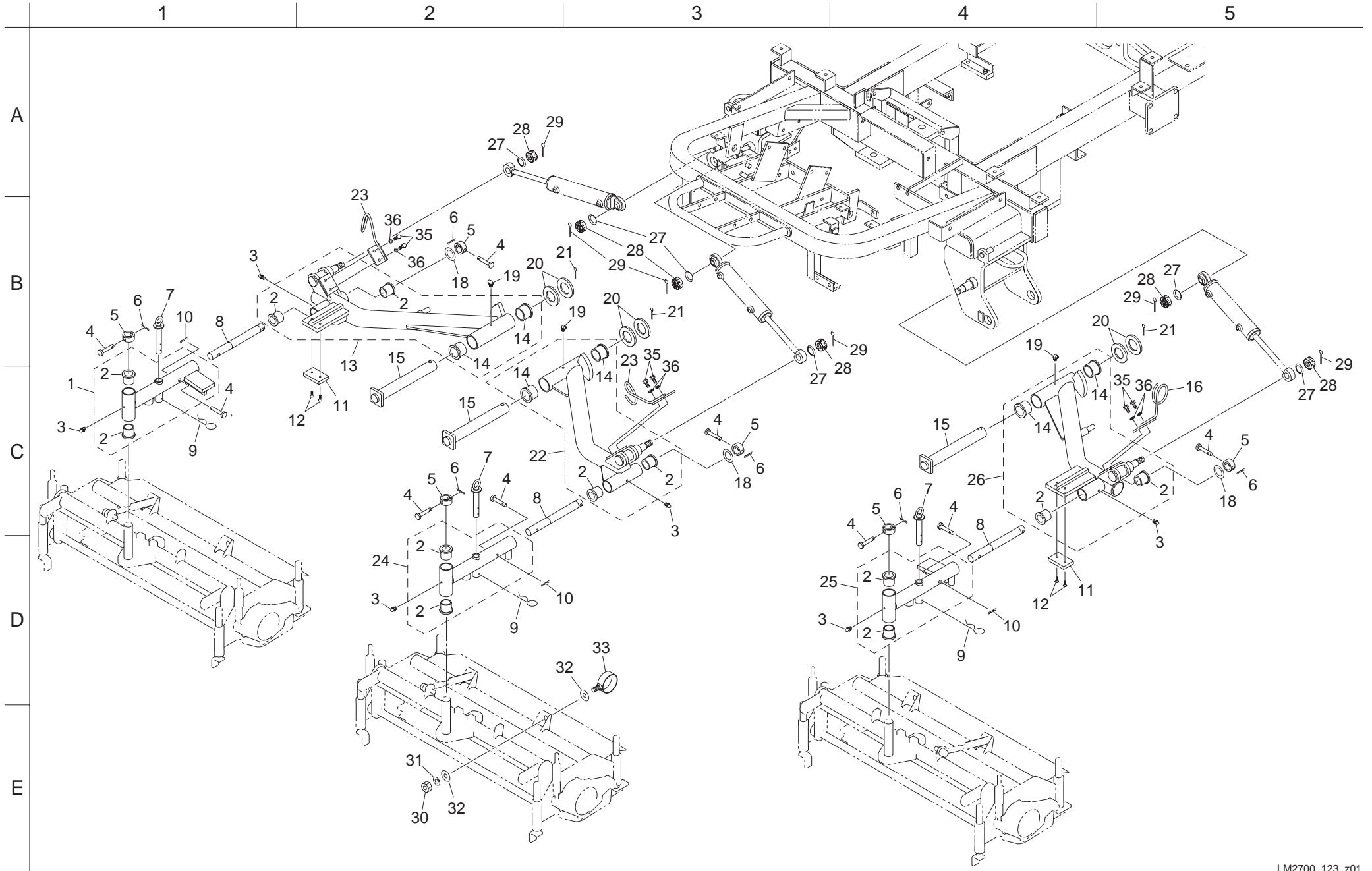

Cat No.	Code No.	Part name	Qty	Remark	SN of application	Cat No.	Code No.	Part name	Qty	Remark	SN of application
123-1	LM2700-0218ZR	JOINT, MOWER #4	1			123-36	K0200080002	WASHER, SPRING M8	6		
123-2	K6010000150	BUSH, FLANGED 25-32-30	12								
123-3	K1440000010	GREASE NIPPLE, A TYPE	6								
123-4	K6031090458	PIN, FLAT HEAD HT M9.6-45.5	9								
123-5	K6215000412	COLLAR, STKM WITH HOLE M25.5-36-16	6								
123-6	K0341000002	PIN, SNAP WITH RETAINER M10	6								
123-7	LM2700-0204A2	PIN, LOCKING	3								
123-8	LM2700-0202Z0	SHAFT	3								
123-9	K0332200008	PIN, SNAP M22	3								
123-10	K0300025202	PIN, COTTER M2.5-20	3								
123-11	K4033000380	RUBBER, PLATE STOPPER	2								
123-12	K0041060152	SCREW, +FLAT HEAD M6-15	4								
123-13	LM2700-2304ZD	ARM, LIFTING #4	1								
123-14	K6010000140	BUSH, FLANGED 30-38-30	6								
123-15	K7147000232	PIN, WITH HOLE M30-197	3								
123-16	LM2700-0234Z2	GUIDE, HOSE D	1								
123-17											
123-18	K5011025372	WASHER, SPCC 1-25.4-37	3	for adjustment							
123-19	K1440000020	GREASE NIPPLE, C	3								
123-20	K5012330452	WASHER, SPCC 2.3-30-45	6								
123-21	K0300040502	PIN, COTTER M4-50	3								
123-22	LM2700-0210ZD	ARM, LIFTING #1	1								
123-23	LM2700-0232Z2	GUIDE, HOSE B	2								
123-24	LM2700-0201ZR	CONNECTOR, MOWER	1								
123-25	LM2700-0217ZR	JOINT, MOWER #5	1								
123-26	LM2700-2305ZD	ARM, LIFTING #5	1								
123-27	K0215160001	WASHER, DISK SPRING H M16-2	6								
123-28	K0122160002	NUT, HIGH SLOTTED P1.5 M16	6								
123-29	K0300032402	PIN, COTTER M3.2-40	6								
123-30	K0100120002	NUT, M12	1								
123-31	K0200120002	WASHER, SPRING M12	1								
123-32	K5000120002	WASHER, M12	2								
123-33	LM2700-0231Z2	GUIDE, HOSE A	1								
123-34											
123-35	K0000080152	BOLT, M8-15	6								

124. 26inch Lift arm rear section

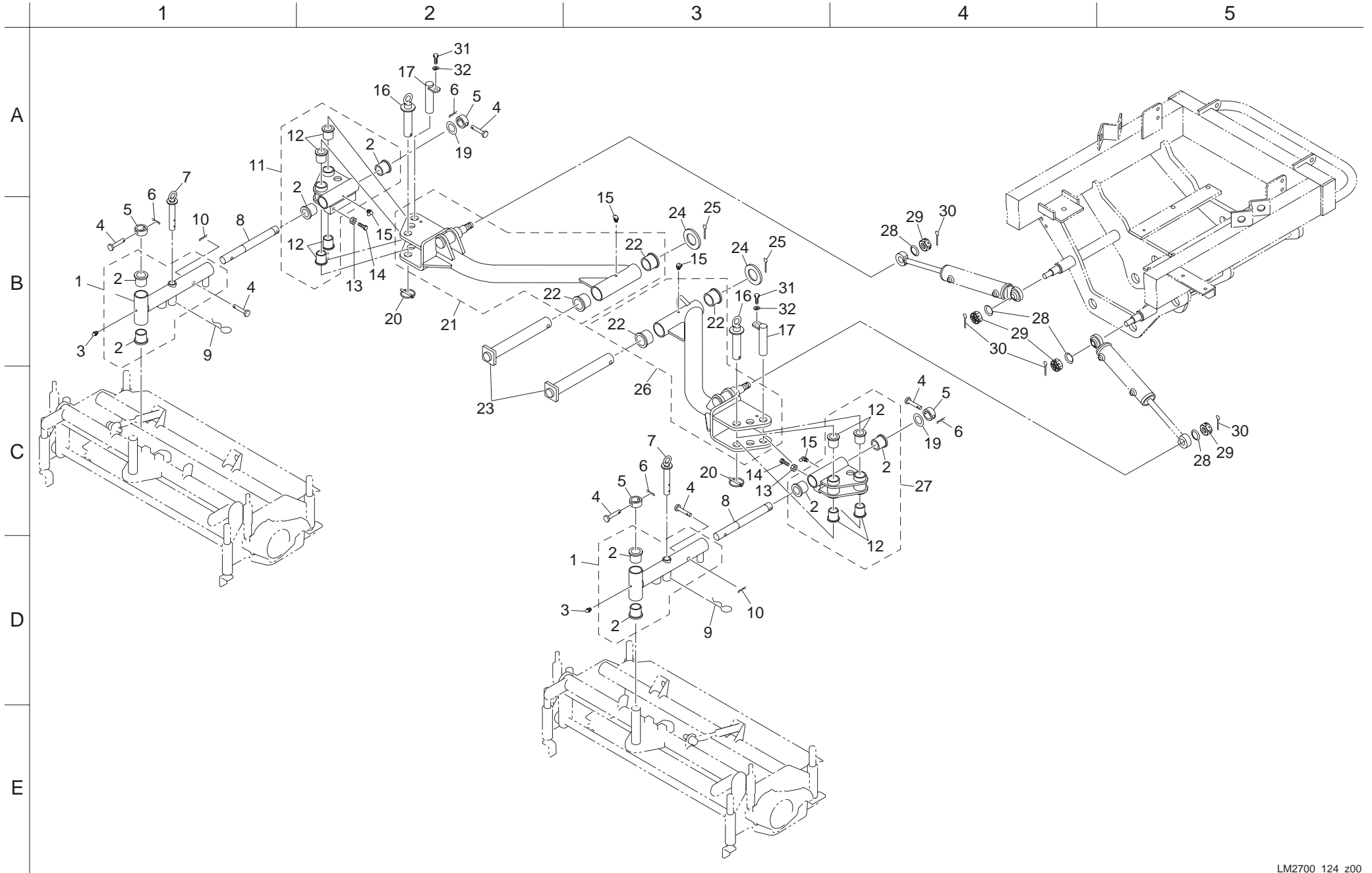

Cat No.	Code No.	Part name	Qty	Remark	SN of application	Cat No.	Code No.	Part name	Qty	Remark	SN of application
124-1	LM2700-0201ZR	CONNECTOR, MOWER	2								
124-2	K6010000150	BUSH, FLANGED 25-32-30	8								
124-3	K1440000010	GREASE NIPPLE, A TYPE	2								
124-4	K6031090458	PIN, FLAT HEAD HT M9.6-45.5	6								
124-5	K6215000412	COLLAR, STKM WITH HOLE M25.5-36-16	4								
124-6	K0341000002	PIN, SNAP WITH RETAINER M10	4								
124-7	LM2700-0204A2	PIN, LOCKING	2								
124-8	LM2700-0202Z0	SHAFT	2								
124-9	K0332200008	PIN, SNAP M22	2								
124-10	K0300025202	PIN, COTTER M2.5-20	2								
124-11	LM2700-0214ZD	JOINT ASSY, SLEWING #2	1								
124-12	K6010000130	BUSH, FLANGED 22-28-30	8								
124-13	K0103100002	NUT, P1.25 M10	2								
124-14	K0011100302	BOLT, HT P1.25 M10-30	2								
124-15	K1440000020	GREASE NIPPLE, C	4								
124-16	LM2700-0216C2	PIN, WITH GRIP	2								
124-17	LM2700-0211B2	SHAFT, SLEWING (REAR)	2								
124-18											
124-19	K5011025372	WASHER, SPCC 1-25.4-37	2	for adjustment							
124-20	K6061060002	PIN, CLIP M6	2								
124-21	LM2700-0213BD	ARM, LIFTING #2	1								
124-22	K6010000140	BUSH, FLANGED 30-38-30	4								
124-23	K7147000232	PIN, WITH HOLE M30-197	2								
124-24	K5011030422	WASHER, SPCC 1-30-42	2								
124-25	K0300040502	PIN, COTTER M4-50	2								
124-26	LM2700-0212BD	ARM, LIFTING #3	1								
124-27	LM2700-0215ZD	JOINT ASSY, SLEWING #3	1								
124-28	K0215160001	WASHER, DISK SPRING H M16-2	4								
124-29	K0122160002	NUT, HIGH SLOTTED P1.5 M16	4								
124-30	K0300032402	PIN, COTTER M3.2-40	4								
124-31	K0000080152	BOLT, M8-15	2								
124-32	K0200080002	WASHER, SPRING M8	2								

125. 22inch Lift arm rear section

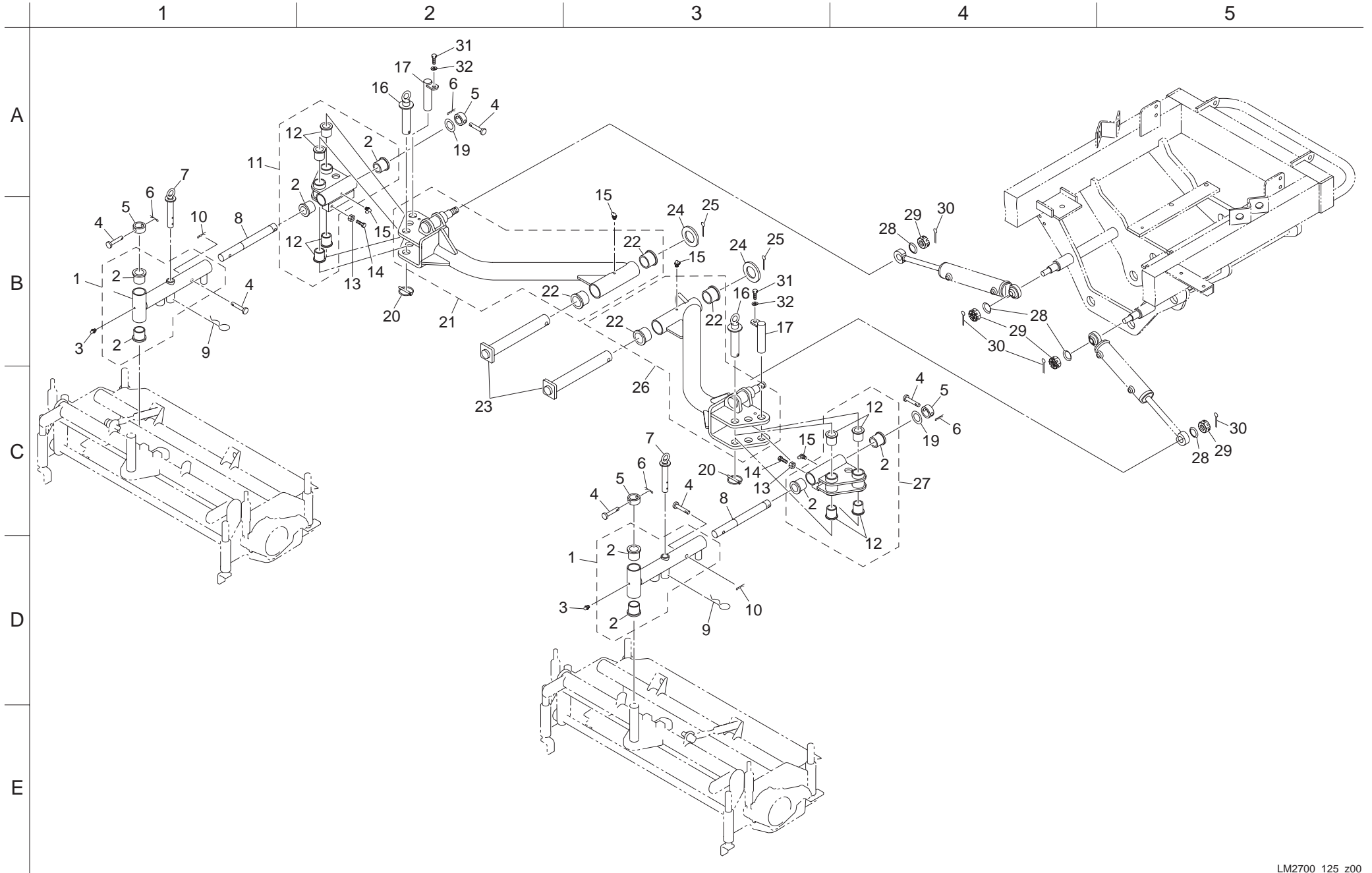

Cat No.	Code No.	Part name	Qty	Remark	SN of application	Cat No.	Code No.	Part name	Qty	Remark	SN of application
125-1	LM2700-0201ZR	CONNECTOR, MOWER	2								
125-2	K6010000150	BUSH, FLANGED 25-32-30	8								
125-3	K1440000010	GREASE NIPPLE, A TYPE	2								
125-4	K6031090458	PIN, FLAT HEAD HT M9.6-45.5	6								
125-5	K6215000412	COLLAR, STKM WITH HOLE M25.5-36-16	4								
125-6	K0341000002	PIN, SNAP WITH RETAINER M10	4								
125-7	LM2700-0204A2	PIN, LOCKING	2								
125-8	LM2700-0202Z0	SHAFT	2								
125-9	K0332200008	PIN, SNAP M22	2								
125-10	K0300025202	PIN, COTTER M2.5-20	2								
125-11	LM2700-0214ZD	JOINT ASSY, SLEWING #2	1								
125-12	K6010000130	BUSH, FLANGED 22-28-30	8								
125-13	K0103100002	NUT, P1.25 M10	2								
125-14	K0011100302	BOLT, HT P1.25 M10-30	2								
125-15	K1440000020	GREASE NIPPLE, C	4								
125-16	LM2700-0216C2	PIN, WITH GRIP	2								
125-17	LM2700-0211B2	SHAFT, SLEWING (REAR)	2								
125-18											
125-19	K5011025372	WASHER, SPCC 1-25.4-37	2	for adjustment							
125-20	K6061060002	PIN, CLIP M6	2								
125-21	LM2700-2302ZD	ARM, LIFTING #2	1								
125-22	K6010000140	BUSH, FLANGED 30-38-30	4								
125-23	K7147000232	PIN, WITH HOLE M30-197	2								
125-24	K5011030422	WASHER, SPCC 1-30-42	2								
125-25	K0300040502	PIN, COTTER M4-50	2								
125-26	LM2700-2303ZD	ARM, LIFTING #3	1								
125-27	LM2700-0215ZD	JOINT ASSY, SLEWING #3	1								
125-28	K0215160001	WASHER, DISK SPRING H M16-2	4								
125-29	K0122160002	NUT, HIGH SLOTTED P1.5 M16	4								
125-30	K0300032402	PIN, COTTER M3.2-40	4								
125-31	K0000080152	BOLT, M8-15	2								
125-32	K0200080002	WASHER, SPRING M8	2								

132. Accessory section

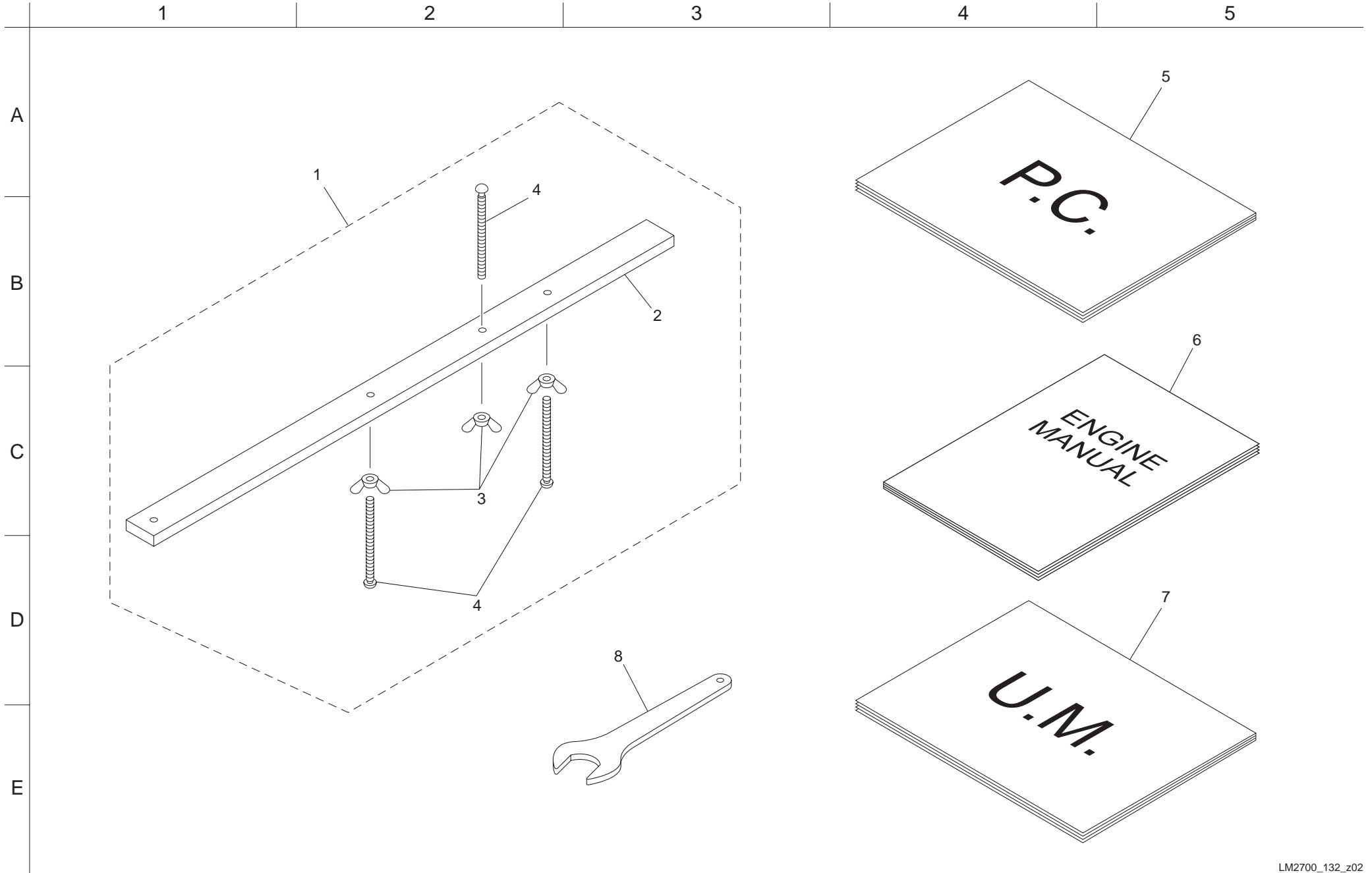

Cat No.	Code No.	Part name	Qty	Remark	SN of application
132-1	LM2700-1502Z0	GAUGE ASSY, CUTTING HEIGHT 600A	1		
132-2	LM2700-1501Z2	GAUGE, CUTTING HEIGHT 600A	1		
132-3	K0141060002	NUT, WING M6-3	3		
132-4	K0071000522	SCREW, FOR CUTTING HEIGHT ADJUST M6-75	3		
132b-5	750101-71-A	OWNERS OPERATING MANUAL, LM2700 (UK)	1		
132a-6	PF1J464-8916-1	MANUAL, KUBOTA ENGINE V2203(EN)	1		
132b-7	750101-71-B	PARTS CATALOG, LM2700 (UK)	1		#10433-
132-8	K480200081D	SPANNER, SLIM SINGLE-ENDED 46	1		

Cat No.	Code No.	Part name	Qty	Remark	SN of application

133. 26inch Grass catcher section (Option)

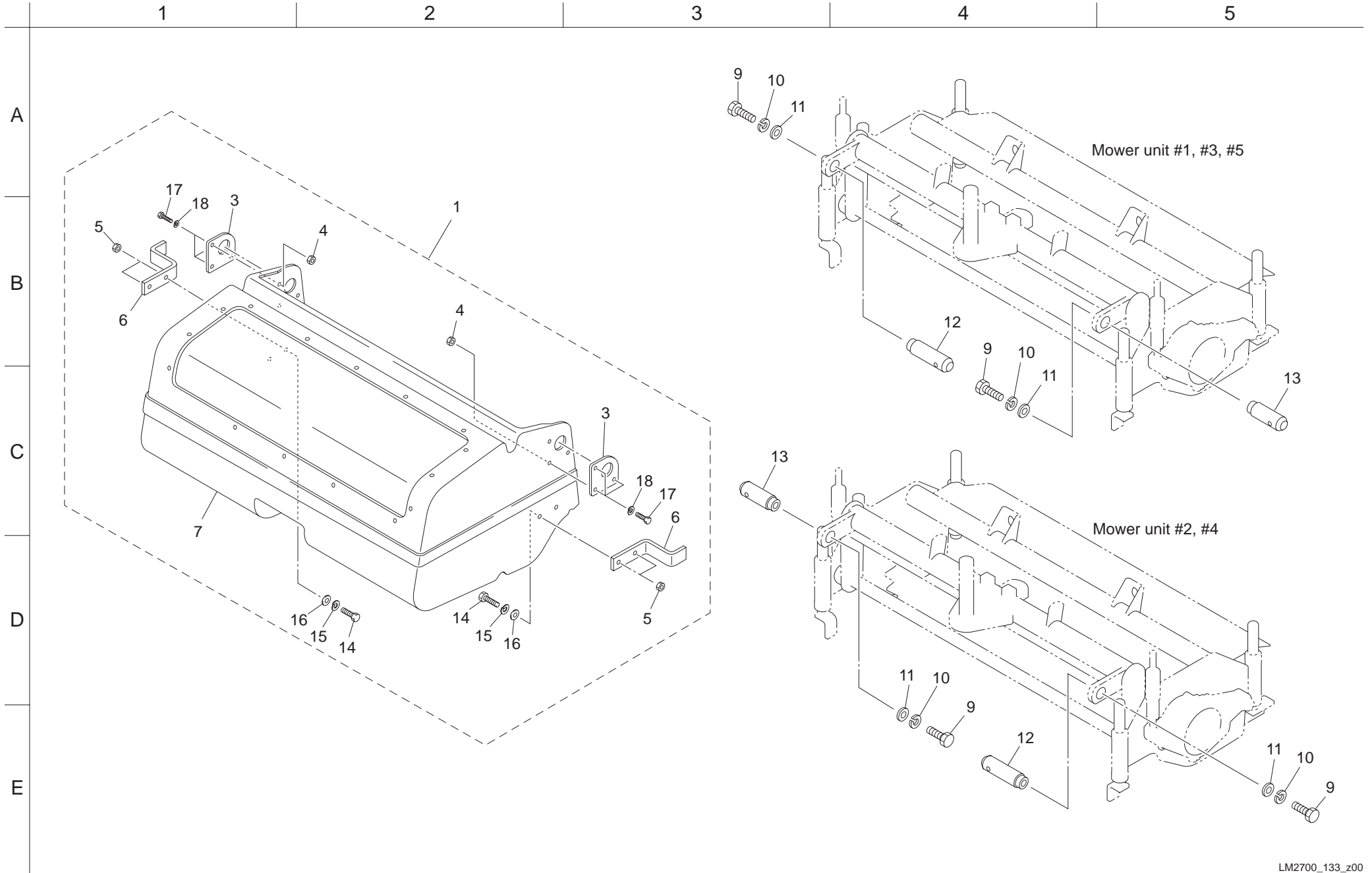

Cat No.	Code No.	Part name	Qty	Remark	SN of application	Cat No.	Code No.	Part name	Qty	Remark	SN of application
133-1	LM2700-1101Z0	BASKET ASSY, 26	5								
133-2											
133-3	LM2700-1110ZD	PLATE, REINFORCEMENT	10								
133-4	K0100060002	NUT, M6	30								
133-5	K0100080002	NUT, M8	20								
133-6	LM2700-1116ZD	STOPPER	10								
133-7	LM2700-1102Z0	BASKET COMP, 26	5								
133-8											
133-9	K0000140252	BOLT, M14-25	10								
133-10	K0200140002	WASHER, SPRING M14	10								
133-11	K5000140002	WASHER, M14	10								
133-12	LM2700-1104Z2	PIN, CATCHER 95	5								
133-13	LM2700-1105Z2	PIN, CATCHER 75	5								
133-14	K0000080202	BOLT, M8-20	20								
133-15	K0200080002	WASHER, SPRING M8	20								
133-16	K5000080002	WASHER, M8	20								
133-17	K0000060202	BOLT, M6-20	30								
133-18	K0200060002	WASHER, SPRING M6	30								

134. 22inch Grass catcher section (Option)

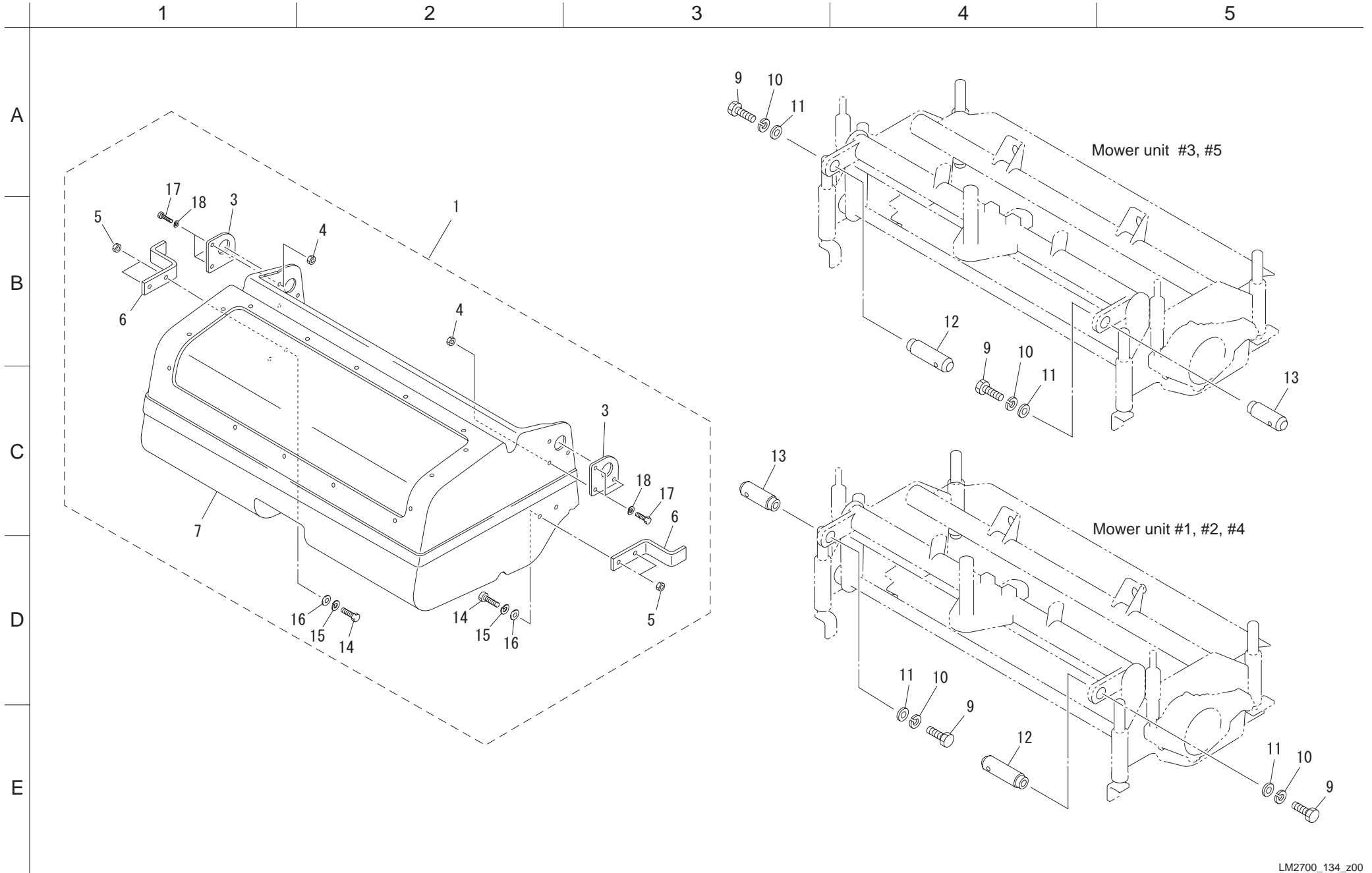

Cat No.	Code No.	Part name	Qty	Remark	SN of application	Cat No.	Code No.	Part name	Qty	Remark	SN of application
134-1	LM2700-2701Z0	BASKET ASSY, 22	5								
134-2											
134-3	LM2700-1110ZD	PLATE, REINFORCEMENT	10								
134-4	K0100060002	NUT, M6	30								
134-5	K0100080002	NUT, M8	20								
134-6	LM2700-1116ZD	STOPPER	10								
134-7	LM2700-2702Z0	BASKET COMP, 22	5								
134-8											
134-9	K0000140252	BOLT, M14-25	10								
134-10	K0200140002	WASHER, SPRING M14	10								
134-11	K5000140002	WASHER, M14	10								
134-12	LM2700-1104Z2	PIN, CATCHER 95	5								
134-13	LM2700-1105Z2	PIN, CATCHER 75	5								
134-14	K0000080202	BOLT, M8-20	20								
134-15	K0200080002	WASHER, SPRING M8	20								
134-16	K5000080002	WASHER, M8	20								
134-17	K0000060202	BOLT, M6-20	30								
134-18	K0200060002	WASHER, SPRING M6	30								

143. Light section

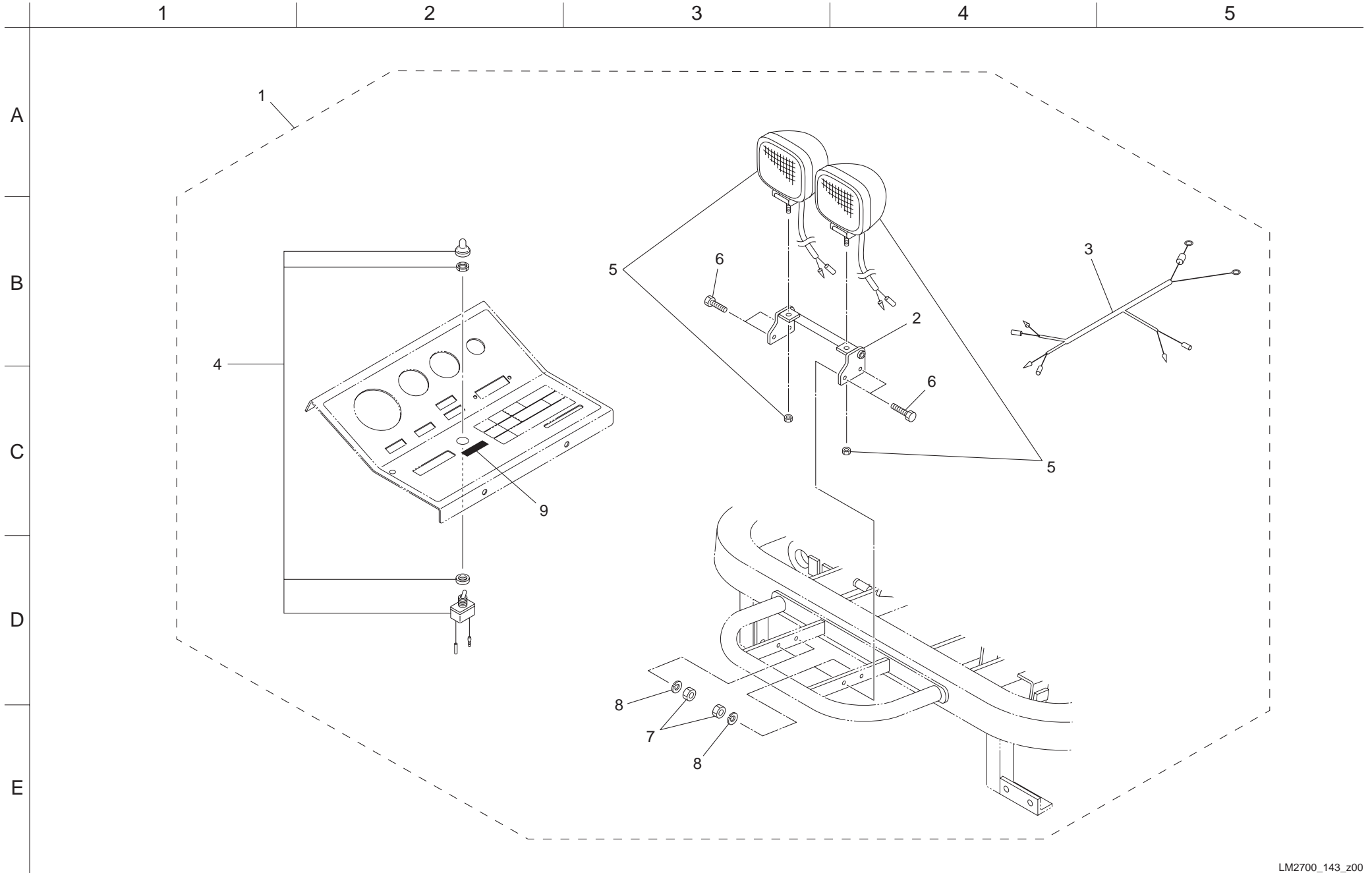

Cat No.	Code No.	Part name	Qty	Remark	SN of application
143-1	LM2700-1703Z0	LAMP KIT, LM2700	1		
143-2	LM2700-1701ZD	BRACKET, LAMP	1		
143-3	LM2700-1702Z0	WIRE, LAMP	1		
143-4	K3662000100	SWITCH, TOGGLE FOR LAMP WD101181	1		
143-5	K3640000070	LAMP, WORKING WL-B220A	2		
143-6	K0000080302	BOLT, M8-30	4		
143-7	K0100080002	NUT, M8	4		
143-8	K0200080002	WASHER, SPRING M8	4		
143-9	K4203001140	STICKER, ON/OFF A	1		

Cat No.	Code No.	Part name	Qty	Remark	SN of application

144. 26inch Mower section A

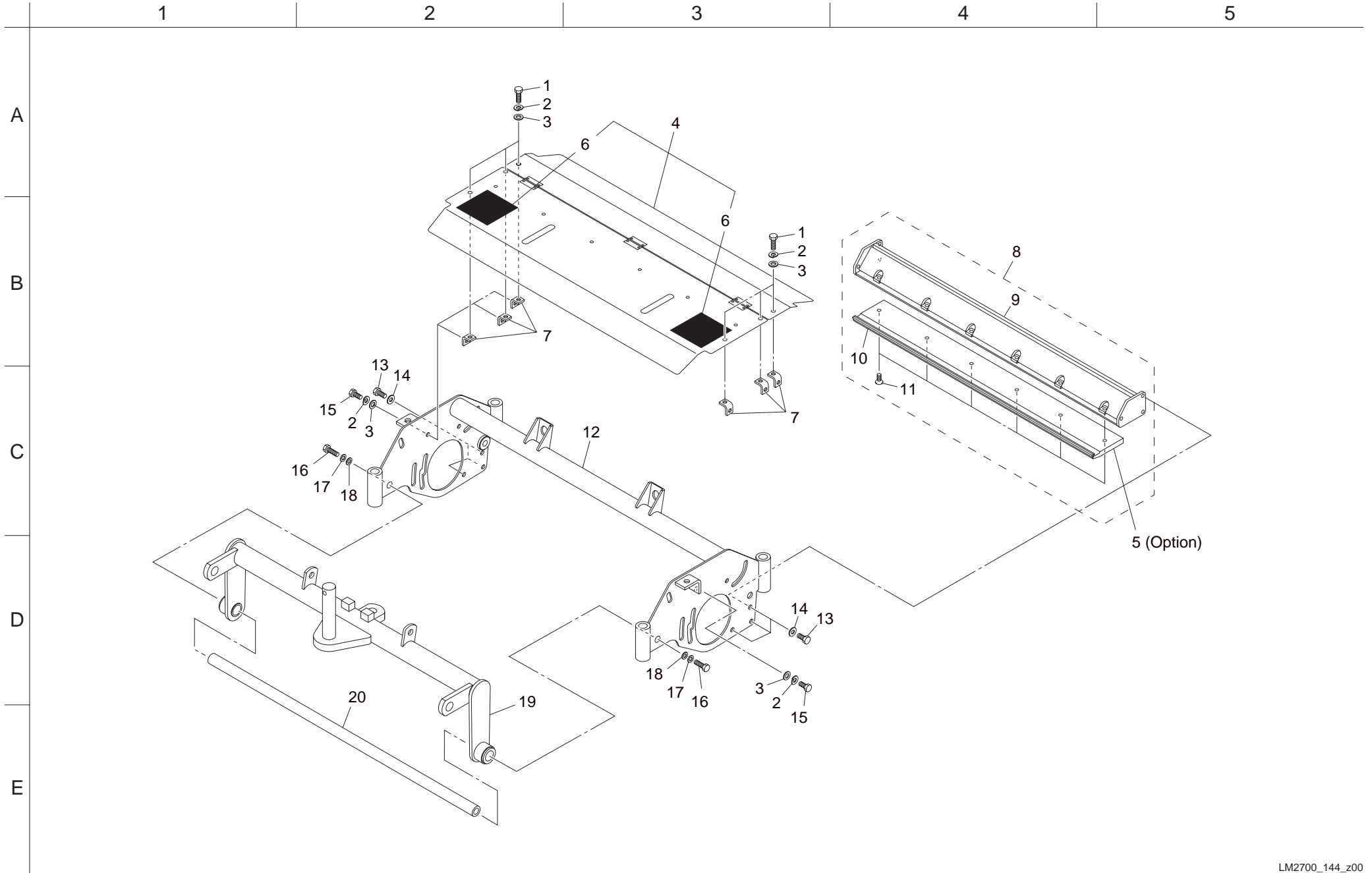

Cat No.	Code No.	Part name	Qty	Remark	SN of application	Cat No.	Code No.	Part name	Qty	Remark	SN of application
144-1	K0000080152	BOLT, M8-15	30								
144-2	K0200080002	WASHER, SPRING M8	60								
144-3	K5000080002	WASHER, M8	60								
144-4	LH6690-0510Z0	COVER COMP, REEL	5								
144-5	K2510000250	BEDKNIFE (BOTTOM BLADE), 5-87-662	5	Option							
144-6	K4205001600	DECAL, CAUTION TO MUTILATION	10								
144-7	LM2700-0139ZR	PLATE, MOUNTING COVER	30								
144-8	LM2700-0117A0	BASE ASSY,BEDKNIFE 732	5								
144-9	LM2700-0116BR	BASE, BEDKNIFE 732	5								
144-10	K2510000030	BEDKNIFE (BOTTOM BLADE), 7-85-662	5								
144-11	K0071001182	SCREW, HT FLAT HEAD M10-16	30								
144-12	LH6690-0101ZR	FRAME MOWER 22	5								
144-13	K0008100202	BOLT, SMALL M10-20	30								
144-14	K0214100002	WASHER, DISK SPRING L M10-2	30								
144-15	K0000080102	BOLT, M8-10	30								
144-16	K0001140252	BOLT, P1.5 M14-25	10								
144-17	K0200140002	WASHER, SPRING M14	10								
144-18	K5000140002	WASHER, M14	10								
144-19	LM2700-0144BR	ARM, MOWER	5								
144-20	LM2700-0140Z8	STAY, FRONT	5								

145. 22inch Mower section A

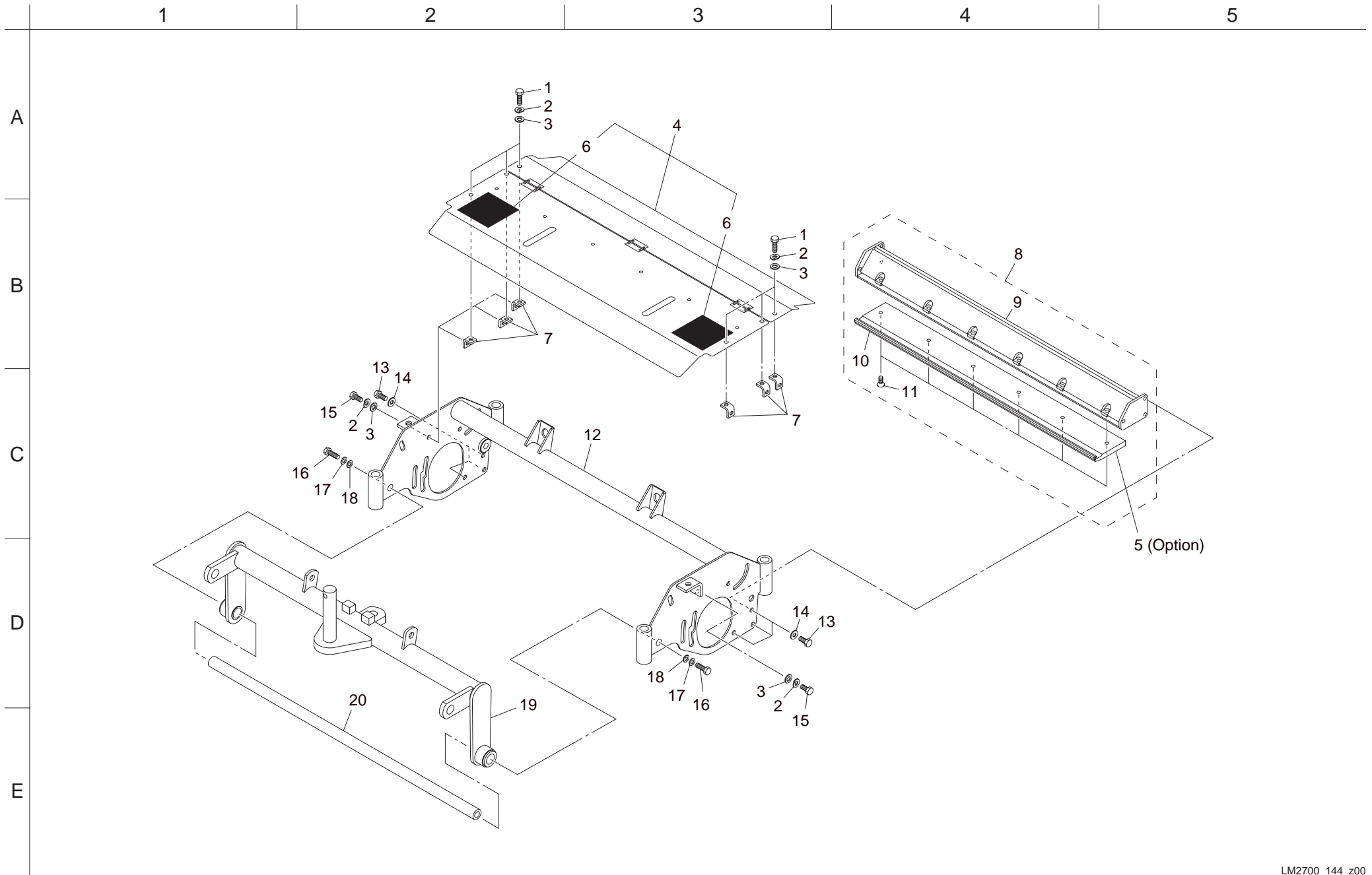

Cat No.	Code No.	Part name	Qty	Remark	SN of application	Cat No.	Code No.	Part name	Qty	Remark	SN of application
145-1	K0000080152	BOLT, M8-15	30								
145-2	K0200080002	WASHER, SPRING M8	60								
145-3	K5000080002	WASHER, M8	60								
145-4	LH6290-0510Z0	COVER COMP, REEL 22	5								
145-5	K2510000280	BEDKNIFE (BOTTOM BLADE), 5.0-87-559	5	Option							
145-6	K4205001600	DECAL, CAUTION TO MUTILATION	10								
145-7	LM2700-0139ZR	PLATE, MOUNTING COVER	30								
145-8	LH6290-0381Z0	BASE ASSY,BEDKNIFE 629.5	5								
145-9	LH6290-0380ZR	BASE, BEDKNIFE 629.5	5								
145-10	K2510000290	BEDKNIFE (BOTTOM BLADE), 7-87-559A	5								
145-11	K0071001182	SCREW, HT FLAT HEAD M10-16	30								
145-12	LH6290-0101ZR	FRAME, MOWER 22	5								
145-13	K0008100202	BOLT, SMALL M10-20	30								
145-14	K0214100002	WASHER, DISK SPRING L M10-2	30								
145-15	K0000080102	BOLT, M8-10	30								
145-16	K0001140252	BOLT, P1.5 M14-25	10								
145-17	K0200140002	WASHER, SPRING M14	10								
145-18	K5000140002	WASHER, M14	10								
145-19	LM2700-2103BR	ARM, MOWER 22	5								
145-20	LM2700-2106Z8	STAY, FRONT 22	5								

146. 26inch Mower section B

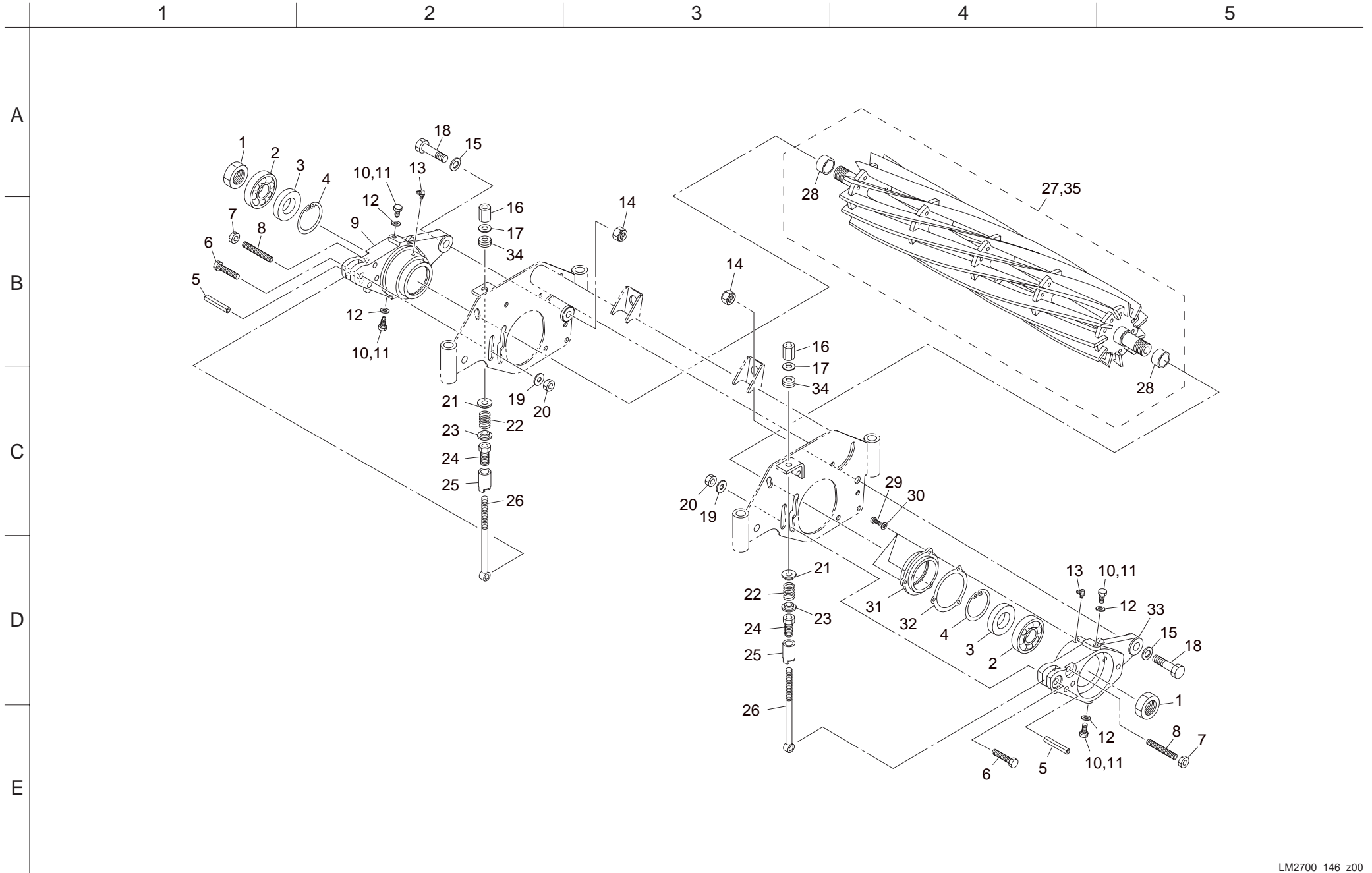

Cat No.	Code No.	Part name	Qty	Remark	SN of application	Cat No.	Code No.	Part name	Qty	Remark	SN of application
146-1	LM2700-0142Z2	NUT, SMALL M30 P2	10								
146-2	K0610062060	BEARING, BALL SEAL RD 6206	10								
146-3	K0823552110	OIL SEAL, MHSA355211	10								
146-4	K0402052001	RING, RETAINING R M52	10								
146-5	K0320100501	PIN, SPRING M10-50	10								
146-6	K0003100502	BOLT, M10-50	10								
146-7	K0102100002	NUT, M10-3	10								
146-8	K0028100601	SETSCREW, SUS M10-60	10								
146-9	LM2700-0149Z0	HOUSING, REEL (R)	5								
146-10	K0000080102	BOLT, M8-10	10	Motor side							
146-11	LM2700-0146A2	BOLT, STOP	10	Groomer side							
146-12	K0922080000	SEAL, WASHER 8WF	20								
146-13	K1440000020	GREASE NIPPLE, C	10								
146-14	K0105140002	NUT, P1.5 M14-3	10								
146-15	K5012314252	WASHER, SPCC 2.3-14-25	10								
146-16	LM56G--0506Z2	NUT, ADJUSTING BEDKNIFE	10								
146-17	K5051010160	WASHER, C5191P 1-10-16	10								
146-18	K0071001132	BOLT, AXIS	10								
146-19	K5073210242	WASHER, SPHC 3.2-10-24	10								
146-20	K0144100002	NUT, WITH F-RING, M10	10								
146-21	K6206000172	RECEIVER, SPRING	10								
146-22	K1000000618	SPRING, COMPRESSION M5-25-35	10								
146-23	K6206000052	RECEIVER , FOR SPRING	10								
146-24	LM535E-1335Z2	PIPE, WITH CUTTER ADJUSTING SCREW	10								
146-25	LM535E-1334Z2	PIPE, ADJUSTING	10								
146-26	K6511000042	BOLT, ADJUSTING CUTTER 170	10								
146-27	LM2700-0192Z0	REEL CUTTER ASSY	5								
146-28	K0737000080	CAGE, INNER FOR NB LRTZ303518	10								
146-29	K0000060152	BOLT, M6-15	15								
146-30	K0212060002	WASHER, DISK SPRING L M6-1	15								
146-31	LM2700-0150Z0	COVER, HOUSING	5								
146-32	LM2700-0130Z0	PACKING, REEL	5								
146-33	LM2700-0148Z0	HOUSING, REEL (L)	5								
146-34	K5090000820	WASHER, SPHERICAL M10	6								
146-35	LM2700-1302Z0	REEL CUTTER ASSY, 26-7	5	Option							

147. 22inch Mower section B

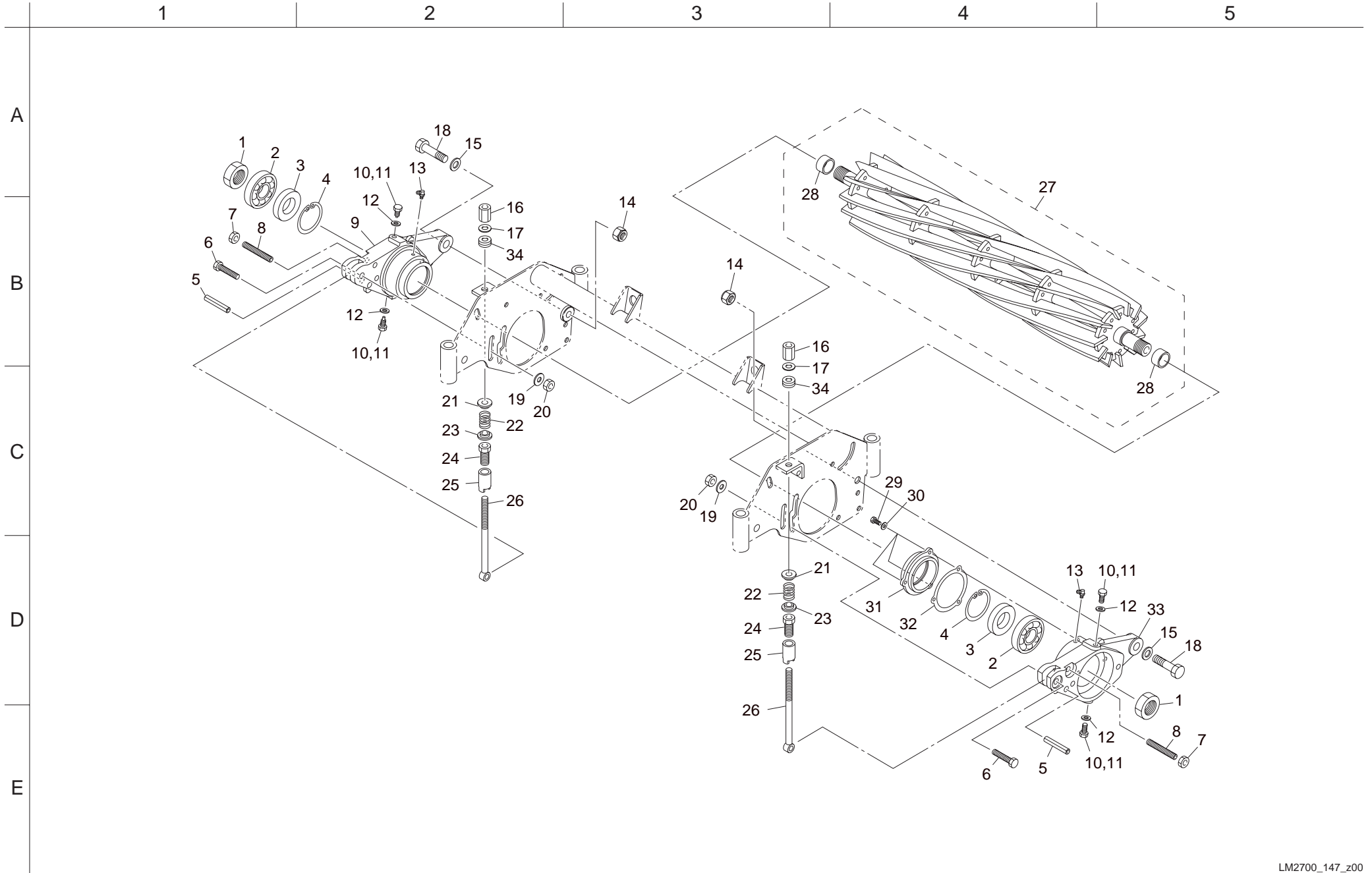

Cat No.	Code No.	Part name	Qty	Remark	SN of application	Cat No.	Code No.	Part name	Qty	Remark	SN of application
147-1	LM2700-0142Z2	NUT, SMALL M30 P2	10								
147-2	K0610062060	BEARING, BALL SEAL RD 6206	10								
147-3	K0823552110	OIL SEAL, MHSA355211	10								
147-4	K0402052001	RING, RETAINING R M52	10								
147-5	K0320100501	PIN, SPRING M10-50	10								
147-6	K0003100502	BOLT, M10-50	10								
147-7	K0102100002	NUT, M10-3	10								
147-8	K0028100601	SETSCREW, SUS M10-60	10								
147-9	LM2700-0149Z0	HOUSING, REEL (R)	5								
147-10	K0000080102	BOLT, M8-10	10	Motor side							
147-11	LM2700-0146A2	BOLT, STOP	10	Groomer side							
147-12	K0922080000	SEAL, WASHER 8WF	20								
147-13	K1440000020	GREASE NIPPLE, C	10								
147-14	K0105140002	NUT, P1.5 M14-3	10								
147-15	K5012314252	WASHER, SPCC 2.3-14-25	10								
147-16	LM56G--0506Z2	NUT, ADJUSTING BEDKNIFE	10								
147-17	K5051010160	WASHER, C5191P 1-10-16	10								
147-18	K0071001132	BOLT, AXIS	10								
147-19	K5073210242	WASHER, SPHC 3.2-10-24	10								
147-20	K0144100002	NUT, WITH F-RING, M10	10								
147-21	K6206000172	RECEIVER, SPRING	10								
147-22	K1000000618	SPRING, COMPRESSION M5-25-35	10								
147-23	K6206000052	RECEIVER , FOR SPRING	10								
147-24	LM535E-1335Z2	PIPE, WITH CUTTER ADJUSTING SCREW	10								
147-25	LM535E-1334Z2	PIPE, ADJUSTING	10								
147-26	K6511000042	BOLT, ADJUSTING CUTTER 170	10								
147-27	LM2700-2114Z0	REEL CUTTER ASSY 22-9	5								
147-28	K0737000080	CAGE, INNER FOR NB LRTZ303518	10								
147-29	K0000060152	BOLT, M6-15	15								
147-30	K0212060002	WASHER, DISK SPRING L M6-1	15								
147-31	LM2700-0150Z0	COVER, HOUSING	5								
147-32	LM2700-0130Z0	PACKING, REEL	5								
147-33	LM2700-0148Z0	HOUSING, REEL (L)	5								
147-34	K5090000820	WASHER, SPHERICAL M10	6								

148. 26inch Mower section C

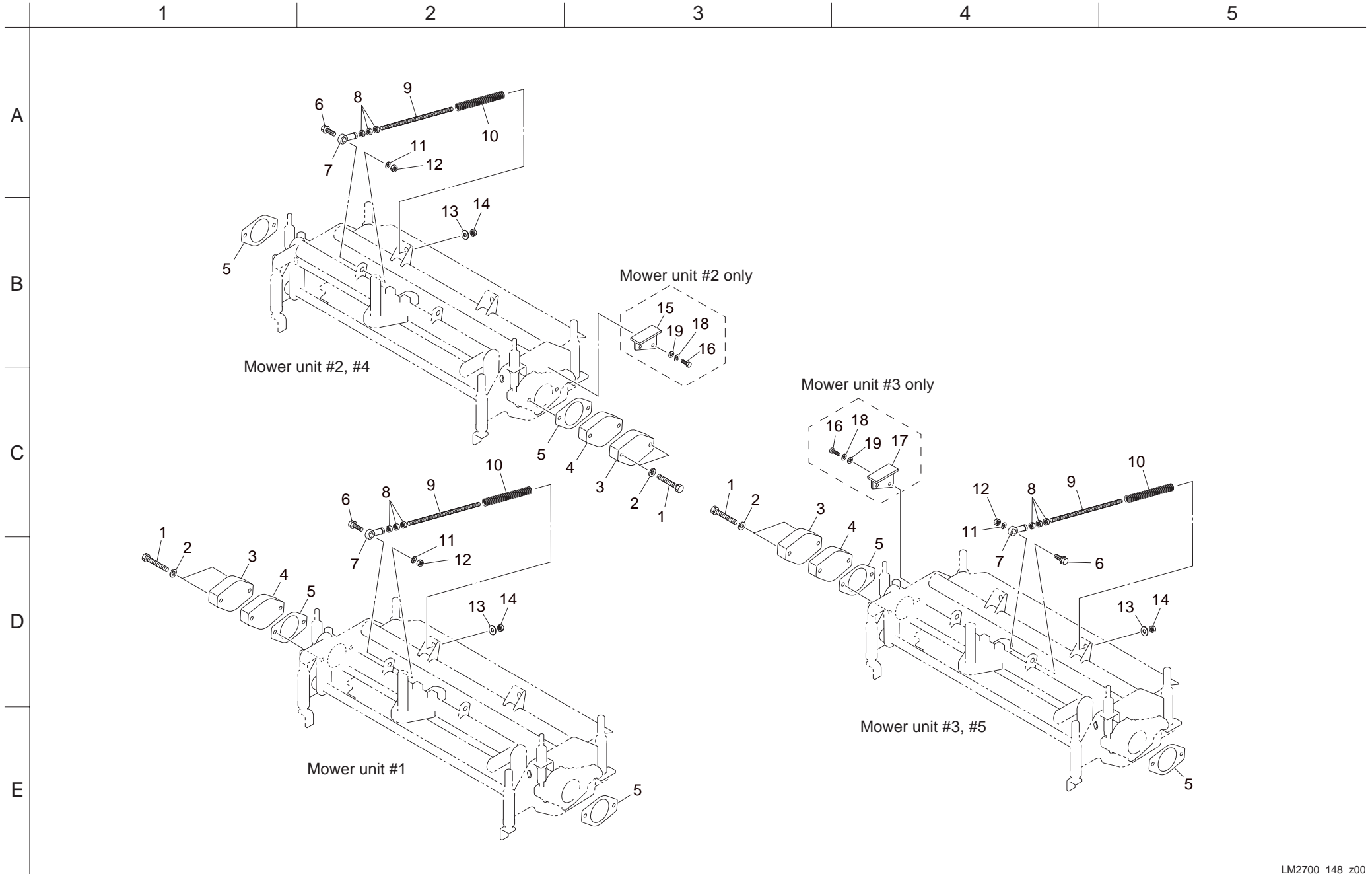

Cat No.	Code No.	Part name	Qty	Remark	SN of application	Cat No.	Code No.	Part name	Qty	Remark	SN of application
148-1	K0000100702	BOLT, M10-70	10								
148-2	K0200100002	WASHER, SPRING M10	10								
148-3	K690300017D	COVER, REEL HOUSING	5								
148-4	LM2700-1201ZD	WEIGHT, MOWER	5								
148-5	K4011000290	PACKING, OIL-SHEET	10								
148-6	K0000120352	BOLT, M12-35	5								
148-7	K1607120000	JOINT, SPHERICAL PHS12EC	5								
148-8	K0102120002	NUT, M12-3	15								
148-9	LM2700-0219Z2	SHAFT, THREADED M12-240	5								
148-10	K1000000118	SPRING, COMPRESSION M3-21-150	5								
148-11	K0200120002	WASHER, SPRING M12	5								
148-12	K0100120002	NUT, M12	5								
148-13	K5073212352	WASHER, SPHC 3.2-12-35	5								
148-14	K0144120002	NUT, WITH F-RING, M12	5								
148-15	LM2700-0166ZD	STOPPER, #2 MOWER	1								
148-16	K0000080202	BOLT, M8-20	4								
148-17	LM2700-0167ZD	STOPPER, #3 MOWER	1								
148-18	K0200080002	WASHER, SPRING M8	4								
148-19	K5000080002	WASHER, M8	4								

149. 22inch Mower section C

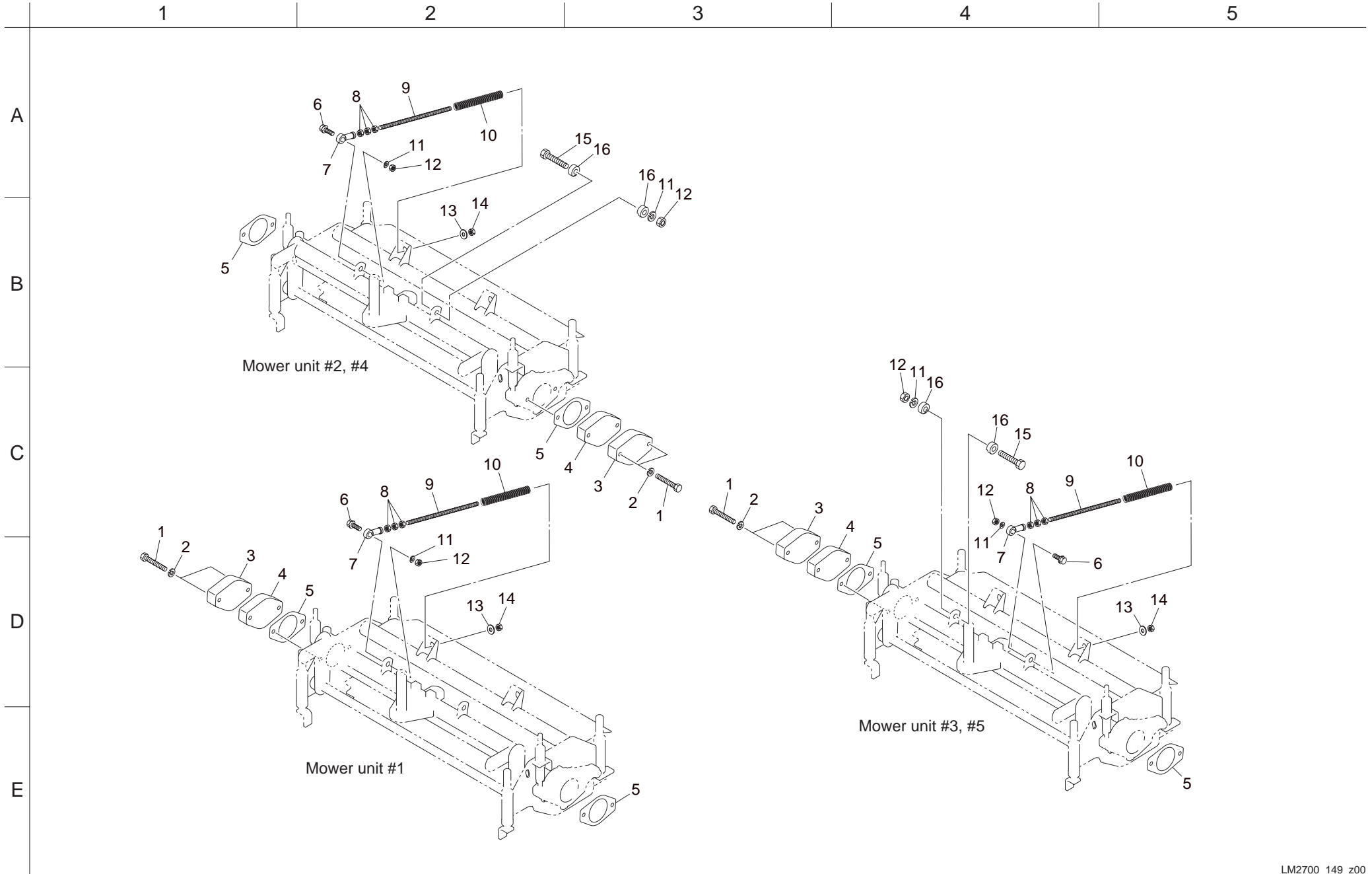

Cat No.	Code No.	Part name	Qty	Remark	SN of application	Cat No.	Code No.	Part name	Qty	Remark	SN of application
149-1	K0000100702	BOLT, M10-70	10								
149-2	K0200100002	WASHER, SPRING M10	10								
149-3	K690300017D	COVER, REEL HOUSING	5								
149-4	LM2700-1201ZD	WEIGHT, MOWER	5								
149-5	K4011000290	PACKING, OIL-SHEET	10								
149-6	K0000120352	BOLT, M12-35	5								
149-7	K1607120000	JOINT, SPHERICAL PHS12EC	5								
149-8	K0102120002	NUT, M12-3	15								
149-9	LM2700-0219Z2	SHAFT, THREADED M12-240	5								
149-10	K1000000118	SPRING, COMPRESSION M3-21-150	5								
149-11	K0200120002	WASHER, SPRING M12	7								
149-12	K0100120002	NUT, M12	7								
149-13	K5073212352	WASHER, SPHC 3.2-12-35	5								
149-14	K0144120002	NUT, WITH F-RING, M12	5								
149-15	K0013120702	BOLT, HT M12-70	2								
149-16	LM2700-2125ZR	STOPPER	4								
149-17	LM2700-0167ZD	STOPPER, #3 MOWER	1								
149-18	K0200080002	WASHER, SPRING M8	4								
149-19	K5000080002	WASHER, M8	4								

150. 26inch Roller Ass'y section A

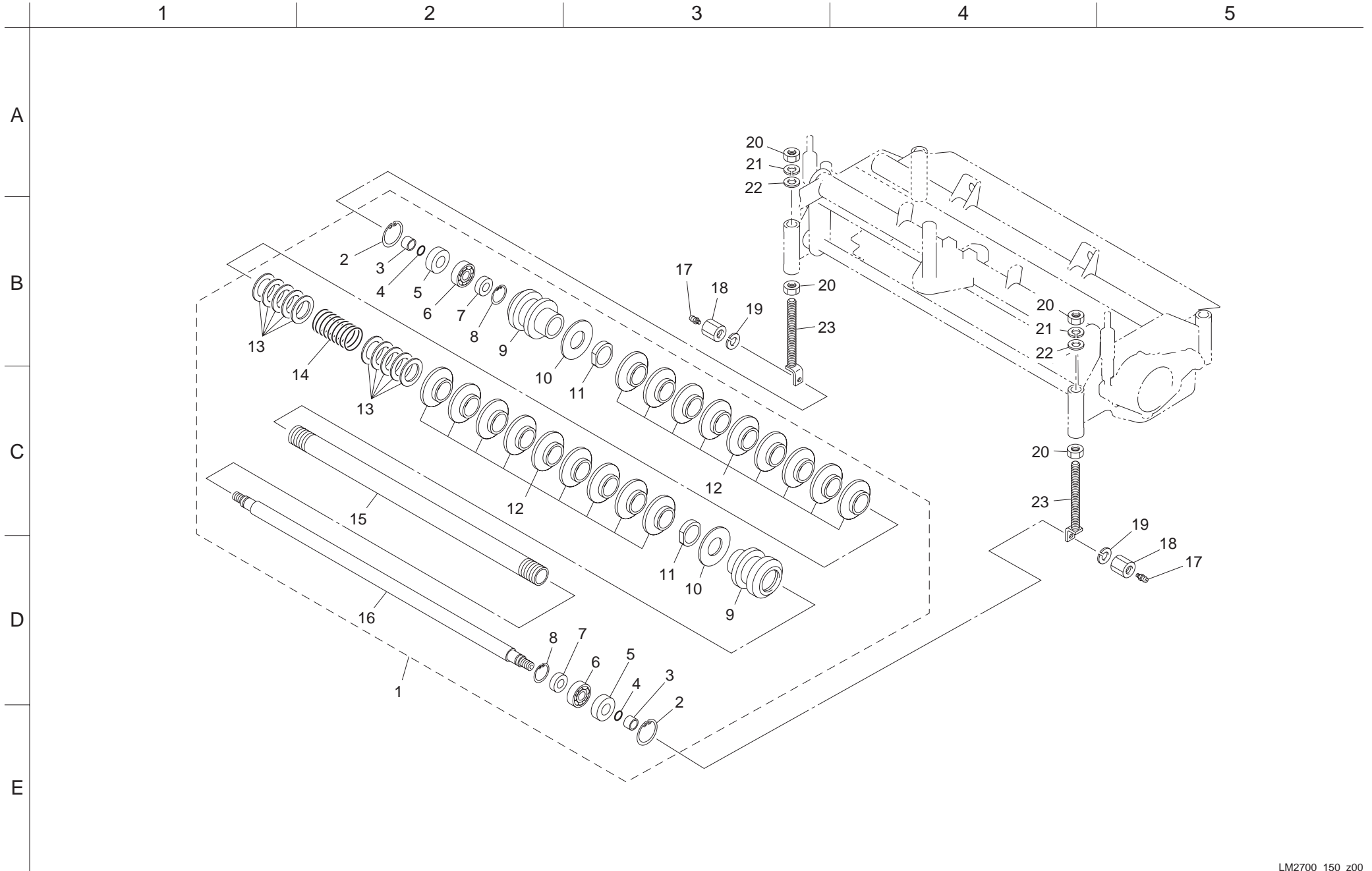

Cat No.	Code No.	Part name	Qty	Remark	SN of application	Cat No.	Code No.	Part name	Qty	Remark	SN of application
150-1	LH6690-0602Z0	ROLLER ASSY	5								
150-2	K0402047001	RING, RETAINING R M47	10								
150-3	K6219000580	COLLAR, SUS M17-25-16	10								
150-4	K0885015000	O-RING, S15	10								
150-5	K0822547080	OIL SEAL, MHSA25478	10								
150-6	K0600063030	BEARING, BALL 6303	10								
150-7	K0822235080	OIL SEAL, MHSA22358	10								
150-8	K0402035001	RING, RETAINING R M35	10								
150-9	LH6690-0601ZD	HOUSING, ROLLER	10								
150-10	K510100061D	PLATE, ROUND 80	10								
150-11	K016000062D	NUT, M40	10								
150-12	K5920000120	ROLLER, PLASTIC 80	90								
150-13	K5011040522	WASHER, SPCC 1-40-52	50	for adjustment							
150-14	K100000073D	SPRING, COMPRESSION M5-51-75	5								
150-15	LM2700-0151Z2	PIPE, ROLLER 34.2-40607.2	5								
150-16	LM2700-0152Z0	SHAFT, ROLLER 22-749	5								
150-17	K1440000010	GREASE NIPPLE, A TYPE	10								
150-18	K0160000652	NUT, SPECIAL M14-30	10								
150-19	K0200140002	WASHER, SPRING M14	10								
150-20	K0108180002	NUT, P1.5 M18-3	20								
150-21	K0200180002	WASHER, SPRING M18	10								
150-22	K5012018282	WASHER, SPCC 2-18-28	10								
150-23	LM2700-0137Z2	SCREW, ADJUSTING CUTTING HEIGHT	10								

151. 22inch Roller Ass'y section A

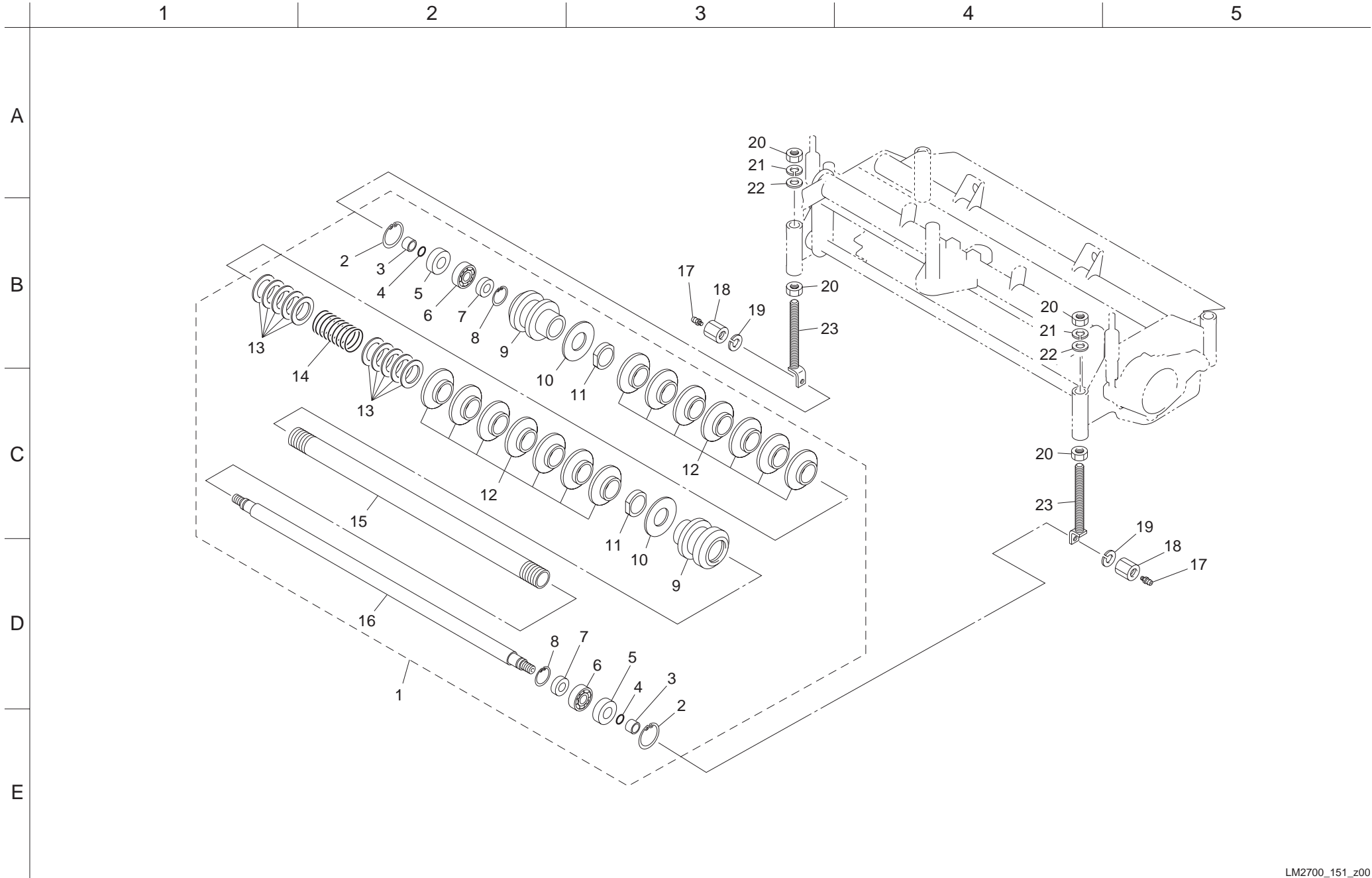

Cat No.	Code No.	Part name	Qty	Remark	SN of application	Cat No.	Code No.	Part name	Qty	Remark	SN of application
151-1	LH6290-0602Z0	ROLLER ASSY 22	5								
151-2	K0402047001	RING, RETAINING R M47	10								
151-3	K6219000580	COLLAR, SUS M17-25-16	10								
151-4	K0885015000	O-RING, S15	10								
151-5	K0822547080	OIL SEAL, MHSA25478	10								
151-6	K0600063030	BEARING, BALL 6303	10								
151-7	K0822235080	OIL SEAL, MHSA22358	10								
151-8	K0402035001	RING, RETAINING R M35	10								
151-9	LH6690-0601ZD	HOUSING, ROLLER	10								
151-10	K510100061D	PLATE, ROUND 80	10								
151-11	K016000062D	NUT, M40	10								
151-12	K5920000120	ROLLER, PLASTIC 80	70								
151-13	K5011040522	WASHER, SPCC 1-40-52	50	for adjustment							
151-14	K100000073D	SPRING, COMPRESSION M5-51-75	5								
151-15	LM2700-2109Z2	PIPE, ROLLER 34.2-40504.7	5								
151-16	LM2700-2107Z0	SHAFT, ROLLER 646.5	5								
151-17	K1440000010	GREASE NIPPLE, A TYPE	10								
151-18	K0160000652	NUT, SPECIAL M14-30	10								
151-19	K0200140002	WASHER, SPRING M14	10								
151-20	K0108180002	NUT, P1.5 M18-3	20								
151-21	K0200180002	WASHER, SPRING M18	10								
151-22	K5012018282	WASHER, SPCC 2-18-28	10								
151-23	LM2700-0137Z2	SCREW, ADJUSTING CUTTING HEIGHT	10								

152. 26inch Roller Ass'y section B

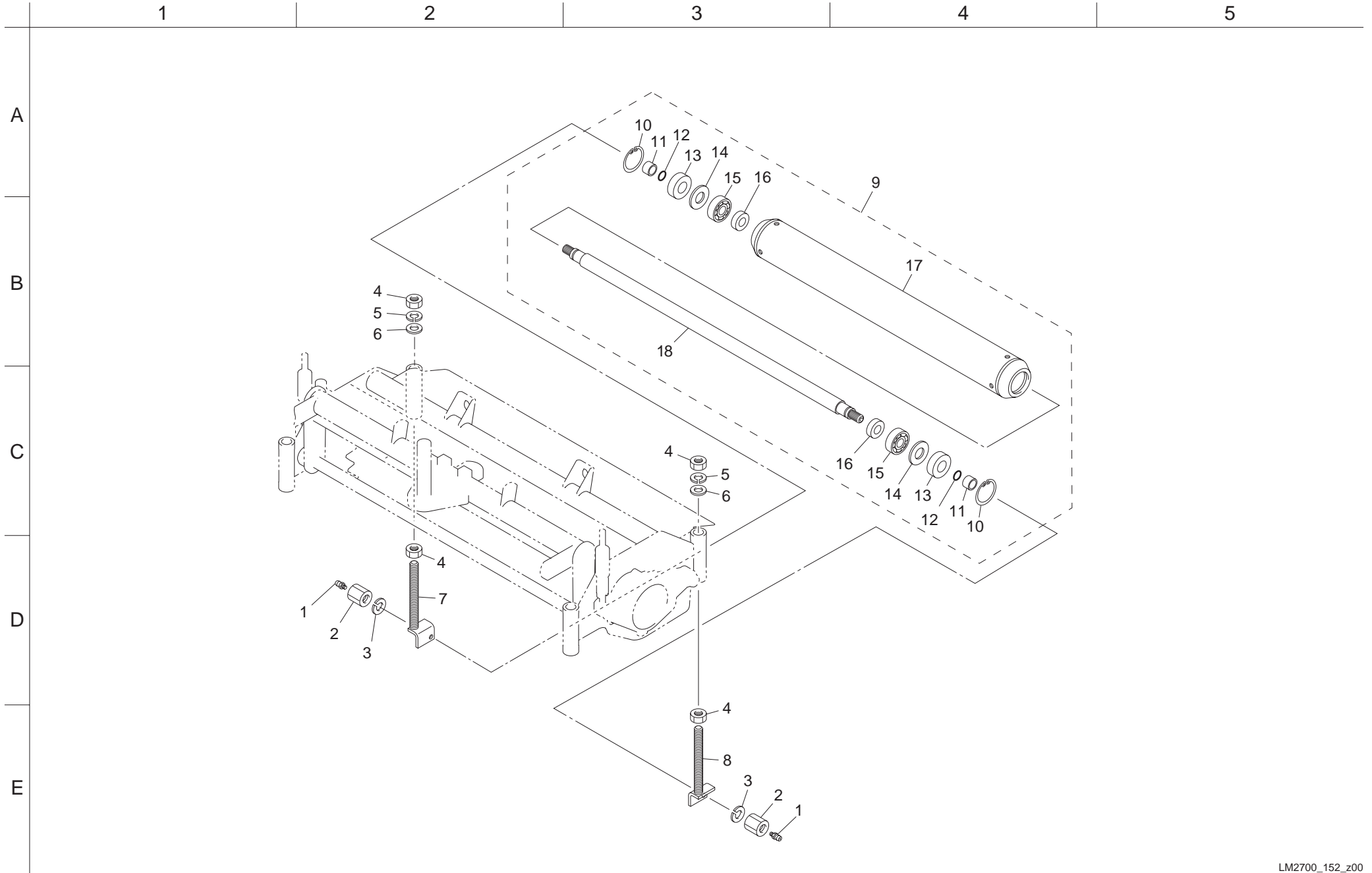

Cat No.	Code No.	Part name	Qty	Remark	SN of application	Cat No.	Code No.	Part name	Qty	Remark	SN of application
152-1	K1440000010	GREASE NIPPLE, A TYPE	10								
152-2	K0160000652	NUT, SPECIAL M14-30	10								
152-3	K0200140002	WASHER, SPRING M14	10								
152-4	K0108180002	NUT, P1.5 M18-3	20								
152-5	K0200180002	WASHER, SPRING M18	10								
152-6	K5012018282	WASHER, SPCC 2-18-28	10								
152-7	LM2700-0161Z2	SCREW, ADJUSTING CUTTING HEIGHT (R)	5								
152-8	LM2700-0162Z2	SCREW, ADJUSTING CUTTING HEIGHT (L)	5								
152-9	LM2700-0193Z0	ROLLER ASSY	5								
152-10	K0402047001	RING, RETAINING R M47	10								
152-11	K6219000580	COLLAR, SUS M17-25-16	10								
152-12	K0885015000	O-RING, S15	10								
152-13	K0822547080	OIL SEAL, MHSA25478	10								
152-14	K5090000802	WASHER, SPHC 3.2-40-47	10								
152-15	K0600063030	BEARING, BALL 6303	10								
152-16	K0822235080	OIL SEAL, MHSA22358	10								
152-17	LM2700-0154ZD	ROLLER, 76.2-696	5								
152-18	LM2700-0152Z0	SHAFT, ROLLER 22-749	5								

153. 22inch Roller Ass'y section B

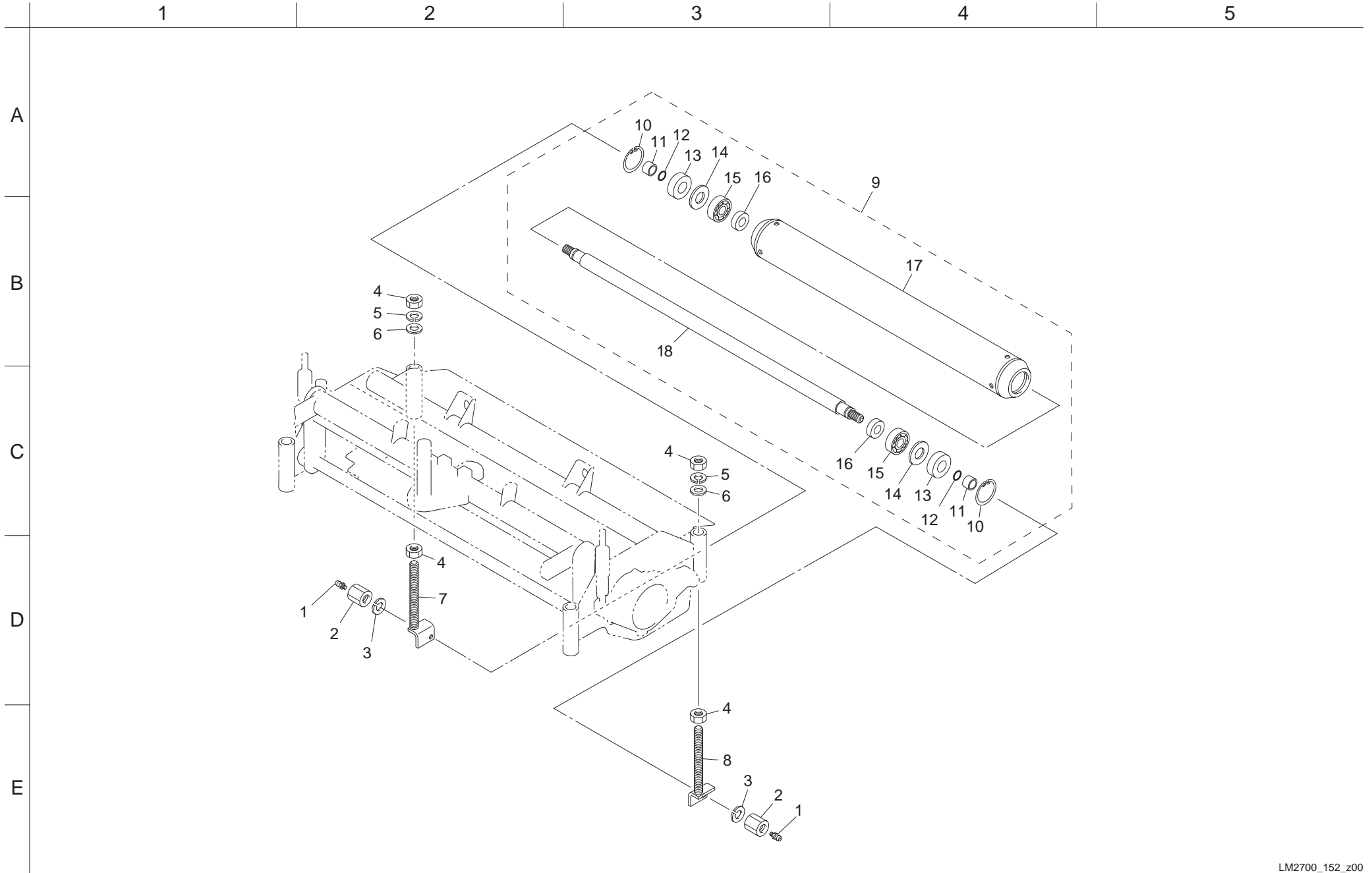

Cat No.	Code No.	Part name	Qty	Remark	SN of application	Cat No.	Code No.	Part name	Qty	Remark	SN of application
153-1	K1440000010	GREASE NIPPLE, A TYPE	10								
153-2	K0160000652	NUT, SPECIAL M14-30	10								
153-3	K0200140002	WASHER, SPRING M14	10								
153-4	K0108180002	NUT, P1.5 M18-3	20								
153-5	K0200180002	WASHER, SPRING M18	10								
153-6	K5012018282	WASHER, SPCC 2-18-28	10								
153-7	LM2700-0161Z2	SCREW, ADJUSTING CUTTING HEIGHT (R)	5								
153-8	LM2700-0162Z2	SCREW, ADJUSTING CUTTING HEIGHT (L)	5								
153-9	LM2700-2117Z0	ROLLER ASSY, 22	5								
153-10	K0402047001	RING, RETAINING R M47	10								
153-11	K6219000580	COLLAR, SUS M17-25-16	10								
153-12	K0885015000	O-RING, S15	10								
153-13	K0822547080	OIL SEAL, MHSA25478	10								
153-14	K5090000802	WASHER, SPHC 3.2-40-47	10								
153-15	K0600063030	BEARING, BALL 6303	10								
153-16	K0822235080	OIL SEAL, MHSA22358	10								
153-17	LM2700-2108ZD	ROLLER, 76.2-593.5	5								
153-18	LM2700-2107Z0	SHAFT, ROLLER 646.5	5								

154. 26inch Groomer Ass'y section A for mower unit #1,#3,#5 (Option)

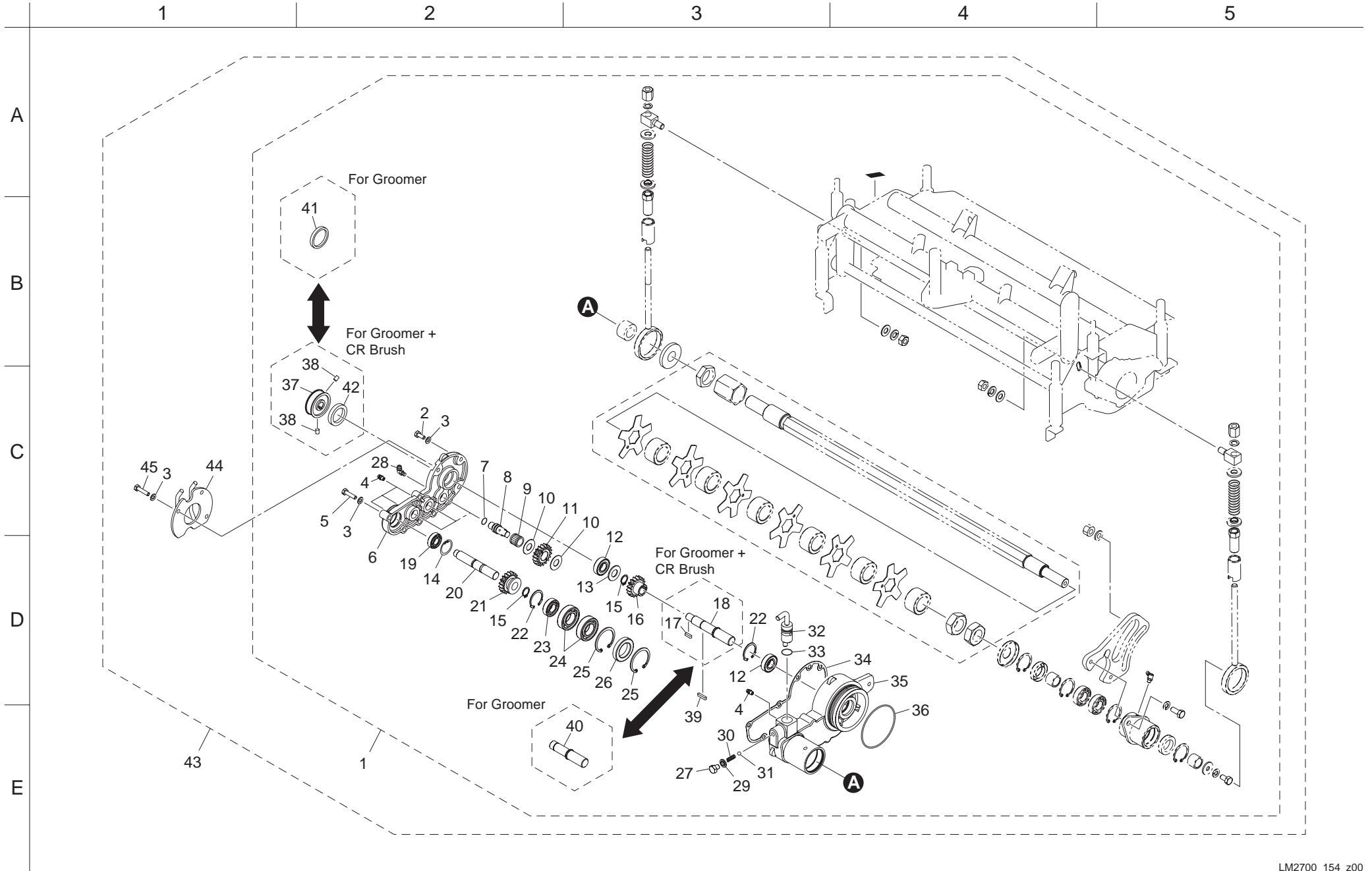

Cat No.	Code No.	Part name	Qty	Remark	SN of application	Cat No.	Code No.	Part name	Qty	Remark	SN of application
154-1	LH669L-1190Z0	GROOMER ASSY, LEFT MOWER	2			154-36	K0885080000	O-RING, S80	3		
154-2	K0000060152	BOLT, M6-15	9			154-37	LM2700-4106Z2	PULLEY, DRIVING	3		
154-3	K0212060002	WASHER, DISK SPRING L M6-1	24			154-38	K0023050081	SETSCREW, M5-8	6		
154-4	K1440000010	GREASE NIPPLE, A TYPE	12			154-39	K0500404180	KEY, BOTH ROUND M4-418	3		
154-5	K0000060252	BOLT, M6-25	12			154-40	LH669L-1101Z0	SHAFT, DRIVE	3		
154-6	LH669L-1302Z0	COVER, GROOMER (R)	3			154-41	K0890000030	CAP, BLANK 25	3		
154-7	K0885014000	O-RING, S14	9			154-42	K0821525070	OIL SEAL, MHSA15257	3		
154-8	LM2700-0111Z0	COUNTERSHAFT	9			154-43	LM2700-3103Z0	GROOMER ASSY, MOWER #5	1	for #5 mower only	
154-9	K0701317120	BEARING, NEEDLE CAGE KT 131712	9			154-44	LM2700-3104Z2	GUARD	1	for #5 mower only	
154-10	K5051013280	WASHER, C5191P 1-13-28	18			154-45	K0000060302	BOLT, M6-30	3	for #5 mower only	
154-11	K6186000030	GEAR, 18 TEETH	9								
154-12	K0612060020	BEARING, BALL SEAL 2RD 6002	6								
154-13	K5051015220	WASHER, C5191P 1-15-22	3								
154-14	K0402028001	RING, RETAINING R M28	3								
154-15	K0401015001	RING, RETAINING S M15	6								
154-16	LH669L-1305Z0	GEAR, 17 TEETH	3								
154-17	K0520404140	KEY, ROUND/SQUARE, M4-414	3								
154-18	LH669L-1304Z0	SHAFT, DRIVE	3								
154-19	K0600006001	BEARING, BALL 6001	3								
154-20	LH669L-1303Z0	SHAFT, SPLINE OUTPUT	3								
154-21	LM2700-0110Z0	GEAR, CLUTCH 18 TEETH	3								
154-22	K0404032001	RING, RETAINING ROUND R M32	6								
154-23	K0600060020	BEARING, 6002	3								
154-24	K0600060220	BEARING, 60/22	6								
154-25	K0402045001	RING, RETAINING R M45	6								
154-26	K0822844080	OIL SEAL, MHSA28448	3								
154-27	K0000080102	BOLT, M8-10	3								
154-28	K1440000020	GREASE NIPPLE, C	3								
154-29	K0922080000	SEAL, WASHER 8WF	3								
154-30	K1000000090	SPRING, COMPRESSION M1-6-18	3								
154-31	K1500635000	BALL, STEEL 6.35	3								
154-32	LH669L-1306Z8	LEVER, CLUTCH (R)	3								
154-33	K0880015000	O-RING, P15	3								
154-34	LM2700-0129A0	PACKING, GROOMER	3								
154-35	LH669L-1301Z0	CASE, GROOMER (R)	3								

155. 22inch Groomer Ass'y section A for mower unit #1,#3,#5 (Option)

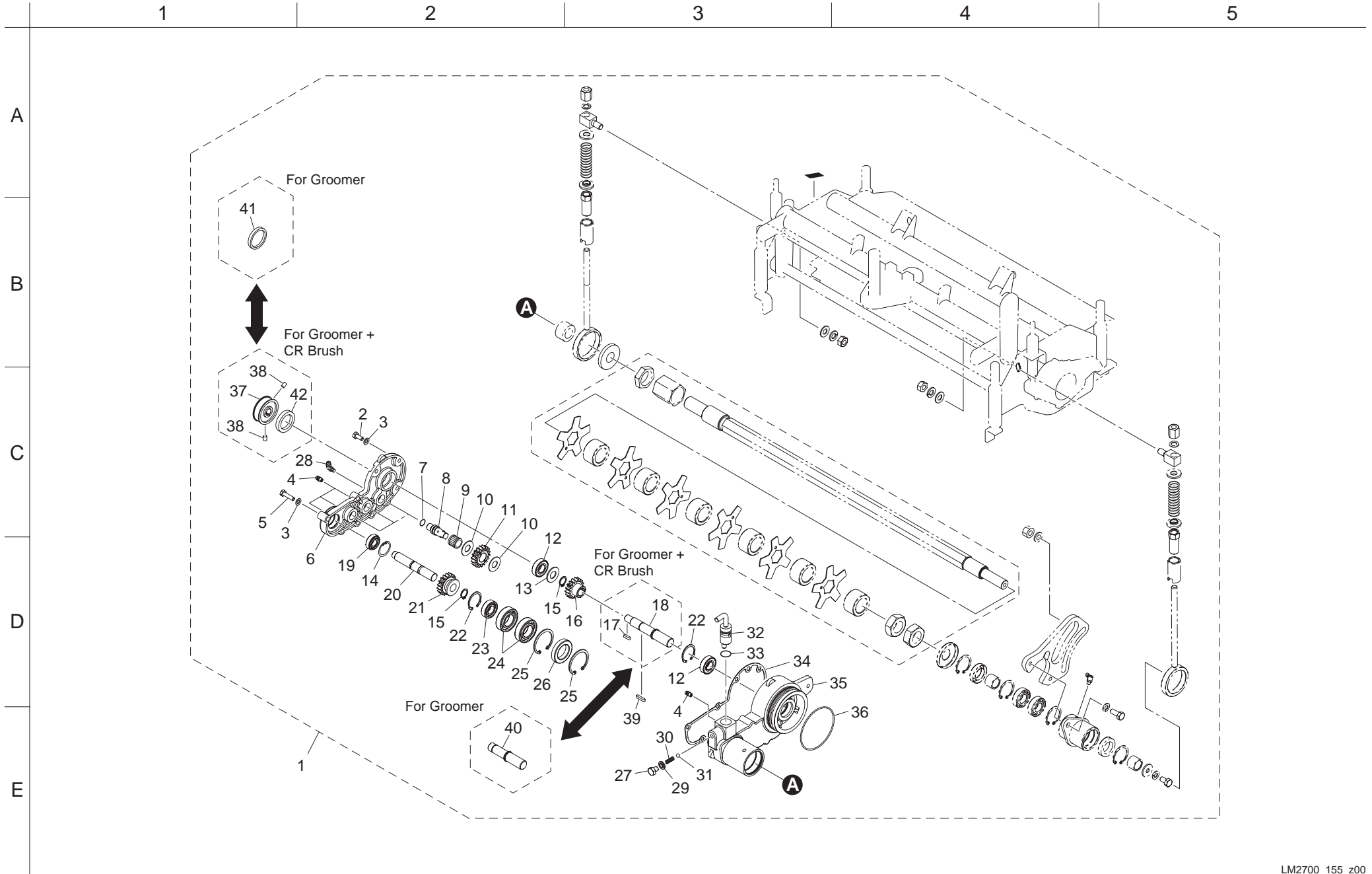

Cat No.	Code No.	Part name	Qty	Remark	SN of application	Cat No.	Code No.	Part name	Qty	Remark	SN of application
155-1	LH629L-1190Z0	GROOMER & GEAR ASSY (L)	3			155-36	K0885080000	O-RING, S80	3		
155-2	K0000060152	BOLT, M6-15	9			155-37	LM2700-4106Z2	PULLEY, DRIVING	3		
155-3	K0212060002	WASHER, DISK SPRING L M6-1	24			155-38	K0023050081	SETSCREW, M5-8	6		
155-4	K1440000010	GREASE NIPPLE, A TYPE	12			155-39	K0500404180	KEY, BOTH ROUND M4-418	3		
155-5	K0000060252	BOLT, M6-25	15			155-40	LH669L-1101Z0	SHAFT, DRIVE	3		
155-6	LH669L-1302Z0	COVER, GROOMER (R)	3			155-41	K0890000030	CAP, BLANK 25	3		
155-7	K0885014000	O-RING, S14	9			155-42	K0821525070	OIL SEAL, MHSA15257	3		
155-8	LM2700-0111Z0	COUNTERSHAFT	9								
155-9	K0701317120	BEARING, NEEDLE CAGE KT 131712	9								
155-10	K5051013280	WASHER, C5191P 1-13-28	18								
155-11	K6186000030	GEAR, 18 TEETH	9								
155-12	K0612060020	BEARING, BALL SEAL 2RD 6002	6								
155-13	K5051015220	WASHER, C5191P 1-15-22	3								
155-14	K0402028001	RING, RETAINING R M28	3								
155-15	K0401015001	RING, RETAINING S M15	6								
155-16	LH669L-1305Z0	GEAR, 17 TEETH	3								
155-17	K0520404140	KEY, ROUND/SQUARE, M4-414	3								
155-18	LH669L-1304Z0	SHAFT, DRIVE	3								
155-19	K0600006001	BEARING, BALL 6001	3								
155-20	LH669L-1303Z0	SHAFT, SPLINE OUTPUT	3								
155-21	LM2700-0110Z0	GEAR, CLUTCH 18 TEETH	3								
155-22	K0404032001	RING, RETAINING ROUND R M32	6								
155-23	K0600060020	BEARING, 6002	3								
155-24	K0600060220	BEARING, 60/22	6								
155-25	K0402045001	RING, RETAINING R M45	6								
155-26	K0822844080	OIL SEAL, MHSA28448	3								
155-27	K0000080102	BOLT, M8-10	3								
155-28	K1440000020	GREASE NIPPLE, C	3								
155-29	K0922080000	SEAL, WASHER 8WF	3								
155-30	K1000000090	SPRING, COMPRESSION M1-6-18	3								
155-31	K1500635000	BALL, STEEL 6.35	3								
155-32	LH669L-1306Z8	LEVER, CLUTCH (R)	3								
155-33	K0880015000	O-RING, P15	3								
155-34	LM2700-0129A0	PACKING, GROOMER	3								
155-35	LH669L-1301Z0	CASE, GROOMER (R)	3								

156. 26inch Groomer Ass'y section B for mower unit #1,#3,#5 (Option)

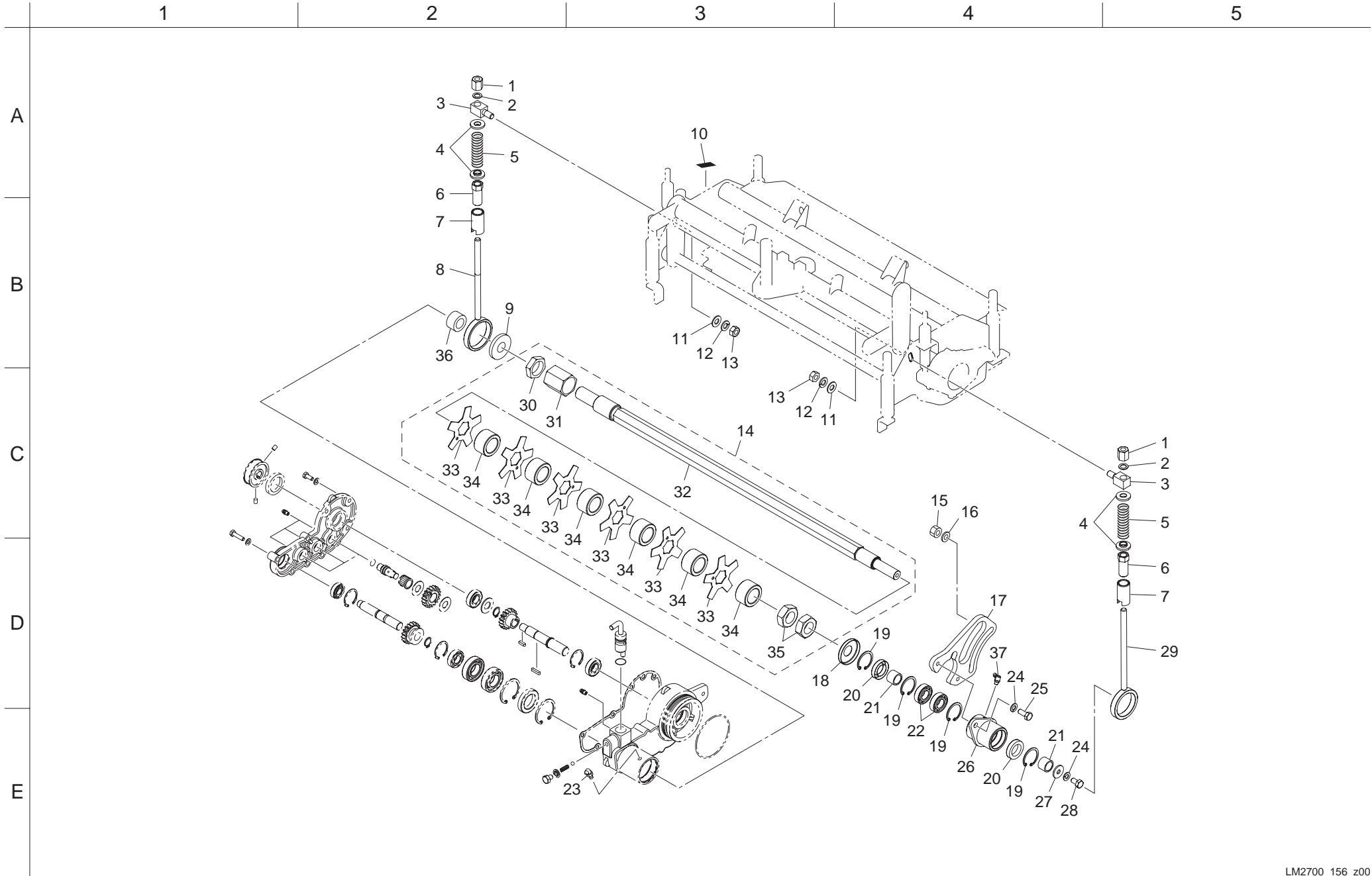

Cat No.	Code No.	Part name	Qty	Remark	SN of application	Cat No.	Code No.	Part name	Qty	Remark	SN of application
156-1	K0160000032	NUT, ADJUSTING BED-KNIFE P1 M10	6			156-36	K0737000090	RACE, INNER LRTZ 222818	3		
156-2	K5051010160	WASHER, C5191P 1-10-16	6			156-37	K1440000020	GREASE NIPPLE, C	3		
156-3	LM2700-0136Z2	RECEIVER, ROD 10	6								
156-4	K6206000052	RECEIVER , FOR SPRING	12								
156-5	K1000000578	SPRING, COMPRESSION M3.5-22-73	6								
156-6	LM535E-1335Z2	PIPE, WITH CUTTER ADJUSTING SCREW	6								
156-7	LM2700-0135Z2	PIPE, ADJUSTING	6								
156-8	LH669L-1313Z2	BOLT, ADJUSTING GROOMER	3								
156-9	LH669L-1310Z2	COVER, CASE DUST PROOF	3								
156-10	K4203000080	STICKER, ON/OFF	3								
156-11	K5000100002	WASHER, M10	6								
156-12	K0200100002	WASHER, SPRING M10	6								
156-13	K0100100002	NUT, M10	6								
156-14	LH669L-1391Z0	SHAFT ASSY, GROOMER	3								
156-15	K0144100002	NUT, WITH F-RING, M10	3								
156-16	K5073210242	WASHER, SPHC 3.2-10-24	3								
156-17	LH669L-1312Z2	BRACKET, GROOMER HOUSING	3								
156-18	K5370000312	COVER, DUST PROOF	3								
156-19	K0402035001	RING, RETAINING R M35	12								
156-20	K0822235080	OIL SEAL, MHSA22358	6								
156-21	K0737000060	CAGE, INNER FOR NB LRT172216	6								
156-22	K0600060030	BEARING, BALL 6003	6								
156-23	K1440000030	GREASE NIPPLE, B	3								
156-24	K0200080002	WASHER, SPRING M8	9								
156-25	K0000080202	BOLT, M8-20	6								
156-26	LH669L-1311Z2	HOUSING, GROOMER (L)	3								
156-27	K5012308242	WASHER, SPCC 2.3-8-24	3								
156-28	K0000080152	BOLT, M8-15	3								
156-29	LM2700-0134A2	BOLT, ADJUSTING GROOMER	3								
156-30	LH669L-1309Z2	NUT, SECURING (SMALL)	3								
156-31	LH669L-1308Z2	NUT, SECURING (LARGE)	3								
156-32	LH669L-1307Z2	SHAFT, GROOMER	3								
156-33	K2570000039	BLADE, VERTICAL 1.2-5-85	69								
156-34	K6214000020	COLLAR, AC M28-42-24.6	69								
156-35	K0108240002	NUT, P1.5 M24-3	6								

157. 22inch Groomer Ass'y section B for mower unit #1,#3,#5 (Option)

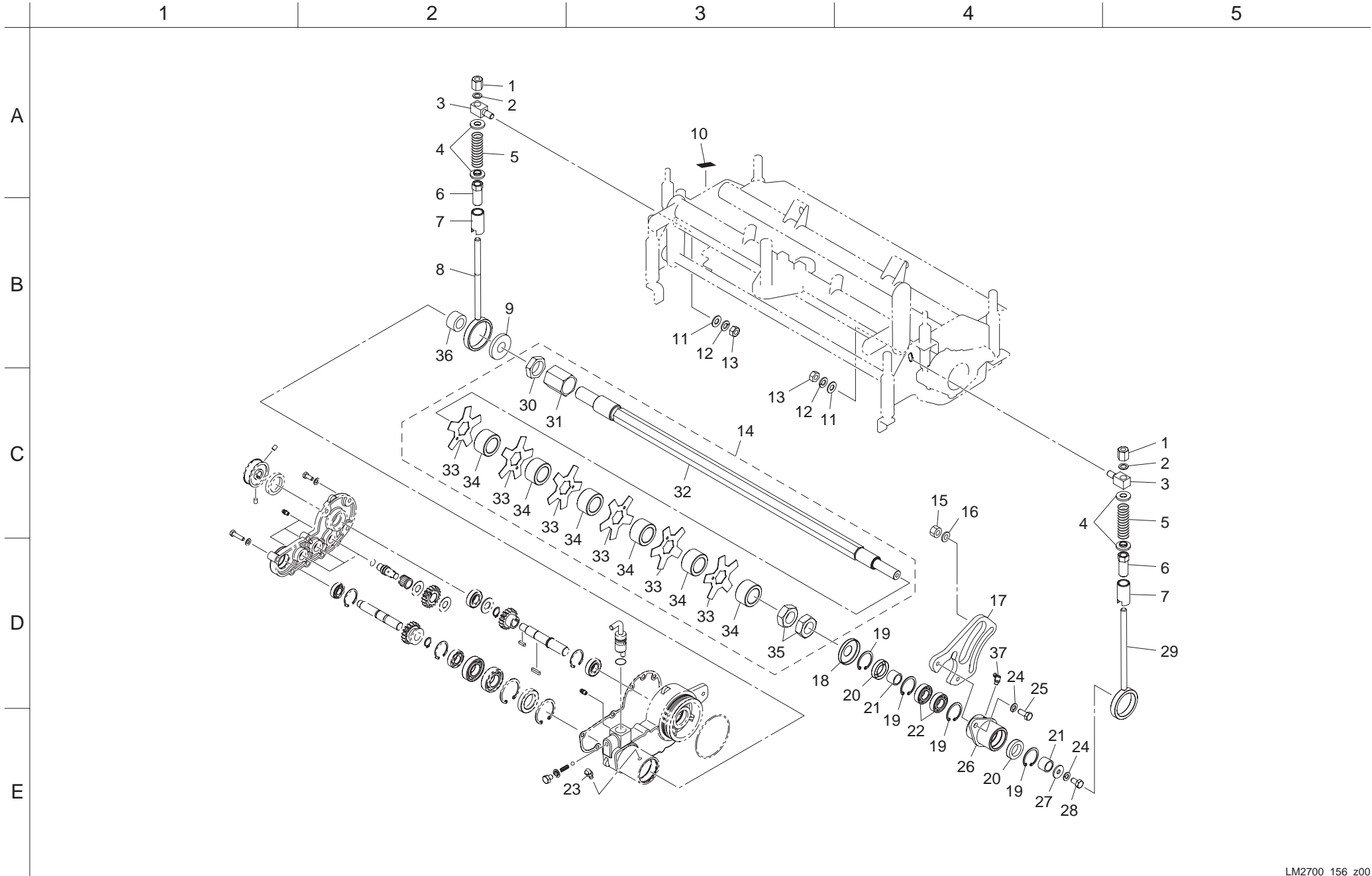

Cat No.	Code No.	Part name	Qty	Remark	SN of application	Cat No.	Code No.	Part name	Qty	Remark	SN of application
157-1	K0160000032	NUT, ADJUSTING BED-KNIFE P1 M10	6			157-36	K0737000090	RACE, INNER LRTZ 222818	3		
157-2	K5051010160	WASHER, C5191P 1-10-16	6			157-37	K1440000020	GREASE NIPPLE, C	3		
157-3	LM2700-0136Z2	RECEIVER, ROD 10	6								
157-4	K6206000052	RECEIVER , FOR SPRING	12								
157-5	K1000000578	SPRING, COMPRESSION M3.5-22-73	6								
157-6	LM535E-1335Z2	PIPE, WITH CUTTER ADJUSTING SCREW	6								
157-7	LM2700-0135Z2	PIPE, ADJUSTING	6								
157-8	LH669L-1313Z2	BOLT, ADJUSTING GROOMER	3								
157-9	LH669L-1310Z2	COVER, CASE DUST PROOF	3								
157-10	K4203000080	STICKER, ON/OFF	3								
157-11	K5000100002	WASHER, M10	6								
157-12	K0200100002	WASHER, SPRING M10	6								
157-13	K0100100002	NUT, M10	6								
157-14	LH629L-1391Z0	SHAFT ASSY, GROOMER 22	3								
157-15	K0144100002	NUT, WITH F-RING, M10	3								
157-16	K5073210242	WASHER, SPHC 3.2-10-24	3								
157-17	LH669L-1312Z2	BRACKET, GROOMER HOUSING	3								
157-18	K5370000312	COVER, DUST PROOF	3								
157-19	K0402035001	RING, RETAINING R M35	12								
157-20	K0822235080	OIL SEAL, MHSA22358	6								
157-21	K0737000060	CAGE, INNER FOR NB LRT172216	6								
157-22	K0600060030	BEARING, BALL 6003	6								
157-23	K1440000030	GREASE NIPPLE, B	3								
157-24	K0200080002	WASHER, SPRING M8	9								
157-25	K0000080202	BOLT, M8-20	6								
157-26	LH669L-1311Z2	HOUSING, GROOMER (L)	3								
157-27	K5012308242	WASHER, SPCC 2.3-8-24	3								
157-28	K0000080152	BOLT, M8-15	3								
157-29	LM2700-0134A2	BOLT, ADJUSTING GROOMER	3								
157-30	LH669L-1309Z2	NUT, SECURING (SMALL)	3								
157-31	LH669L-1308Z2	NUT, SECURING (LARGE)	3								
157-32	LH629L-1301Z2	SHAFT, GROOMER 22	3								
157-33	K2570000039	BLADE, VERTICAL 1.2-5-85	46								
157-34	K6214000020	COLLAR, AC M28-42-24.6	46								
157-35	K0108240002	NUT, P1.5 M24-3	6								

158. 26inch Groomer Ass'y section A for mower unit #2,#4 (Option)

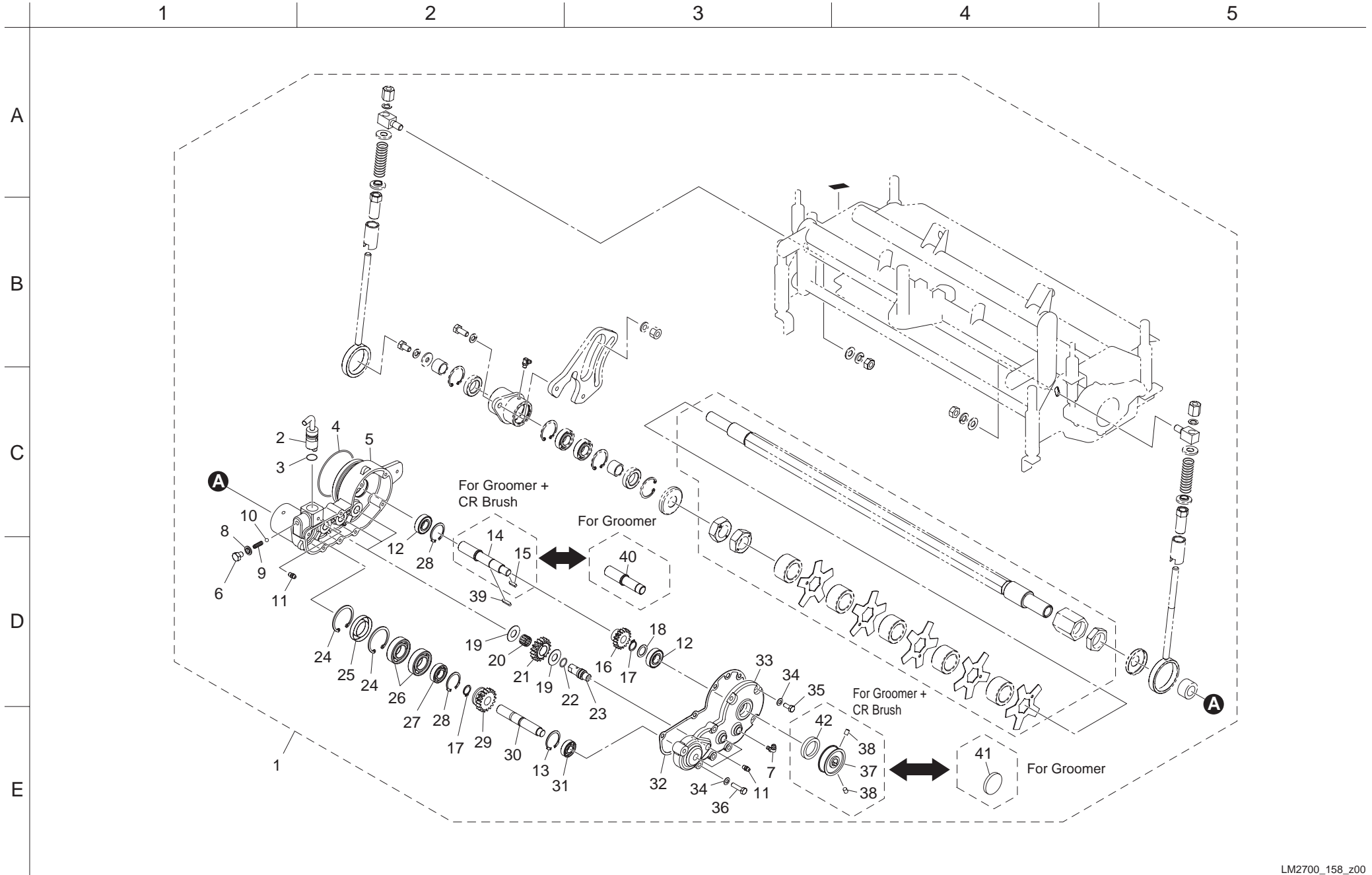

Cat No.	Code No.	Part name	Qty	Remark	SN of application	Cat No.	Code No.	Part name	Qty	Remark	SN of application
158-1	LH669R-1190Z0	GROOMER ASSY, RIGHT MOWER	2			158-36	K0000060252	BOLT, M6-25	10		
158-2	LH669R-1303Z8	LEVER, CLUTCH (L)	2			158-37	LM2700-4106Z2	PULLEY, DRIVING	2		
158-3	K0880015000	O-RING, P15	2			158-38	K0023050081	SETSCREW, M5-8	4		
158-4	K0885080000	O-RING, S80	2			158-39	K0500404180	KEY, BOTH ROUND M4-418	2		
158-5	LH669R-1301Z0	CASE, GROOMER (L)	2			158-40	LH669L-1101Z0	SHAFT, DRIVE	2		
158-6	K0000080102	BOLT, M8-10	2			158-41	K0890000030	CAP, BLANK 25	2		
158-7	K1440000020	GREASE NIPPLE, C	2			158-42	K0821525070	OIL SEAL, MHSA15257	2		
158-8	K0922080000	SEAL, WASHER 8WF	2								
158-9	K1000000090	SPRING, COMPRESSION M1-6-18	2								
158-10	K1500635000	BALL, STEEL 6.35	2								
158-11	K1440000010	GREASE NIPPLE, A TYPE	8								
158-12	K0612060020	BEARING, BALL SEAL 2RD 6002	4								
158-13	K0402028001	RING, RETAINING R M28	2								
158-14	LH669L-1304Z0	SHAFT, DRIVE	2								
158-15	K0520404140	KEY, ROUND/SQUARE, M4-414	2								
158-16	LH669L-1305Z0	GEAR, 17 TEETH	2								
158-17	K0401015001	RING, RETAINING S M15	4								
158-18	K5051015220	WASHER, C5191P 1-15-22	2								
158-19	K5051013280	WASHER, C5191P 1-13-28	12								
158-20	K0701317120	BEARING, NEEDLE CAGE KT 131712	6								
158-21	K6186000030	GEAR, 18 TEETH	6								
158-22	K0885014000	O-RING, S14	6								
158-23	LM2700-0111Z0	COUNTERSHAFT	6								
158-24	K0402045001	RING, RETAINING R M45	4								
158-25	K0822844080	OIL SEAL, MHSA28448	2								
158-26	K0600060220	BEARING, 60/22	4								
158-27	K0600060020	BEARING, 6002	2								
158-28	K0404032001	RING, RETAINING ROUND R M32	2								
158-29	LM2700-0110Z0	GEAR, CLUTCH 18 TEETH	2								
158-30	LH669L-1303Z0	SHAFT, SPLINE OUTPUT	2								
158-31	K0600006001	BEARING, BALL 6001	2								
158-32	LM2700-0129A0	PACKING, GROOMER	2								
158-33	LH669R-1302Z0	COVER, GROOMER (L)	2								
158-34	K0212060002	WASHER, DISK SPRING L M6-1	16								
158-35	K0000060152	BOLT, M6-15	6								

159. 22inch Groomer Ass'y section A for mower unit #2,#4 (Option)

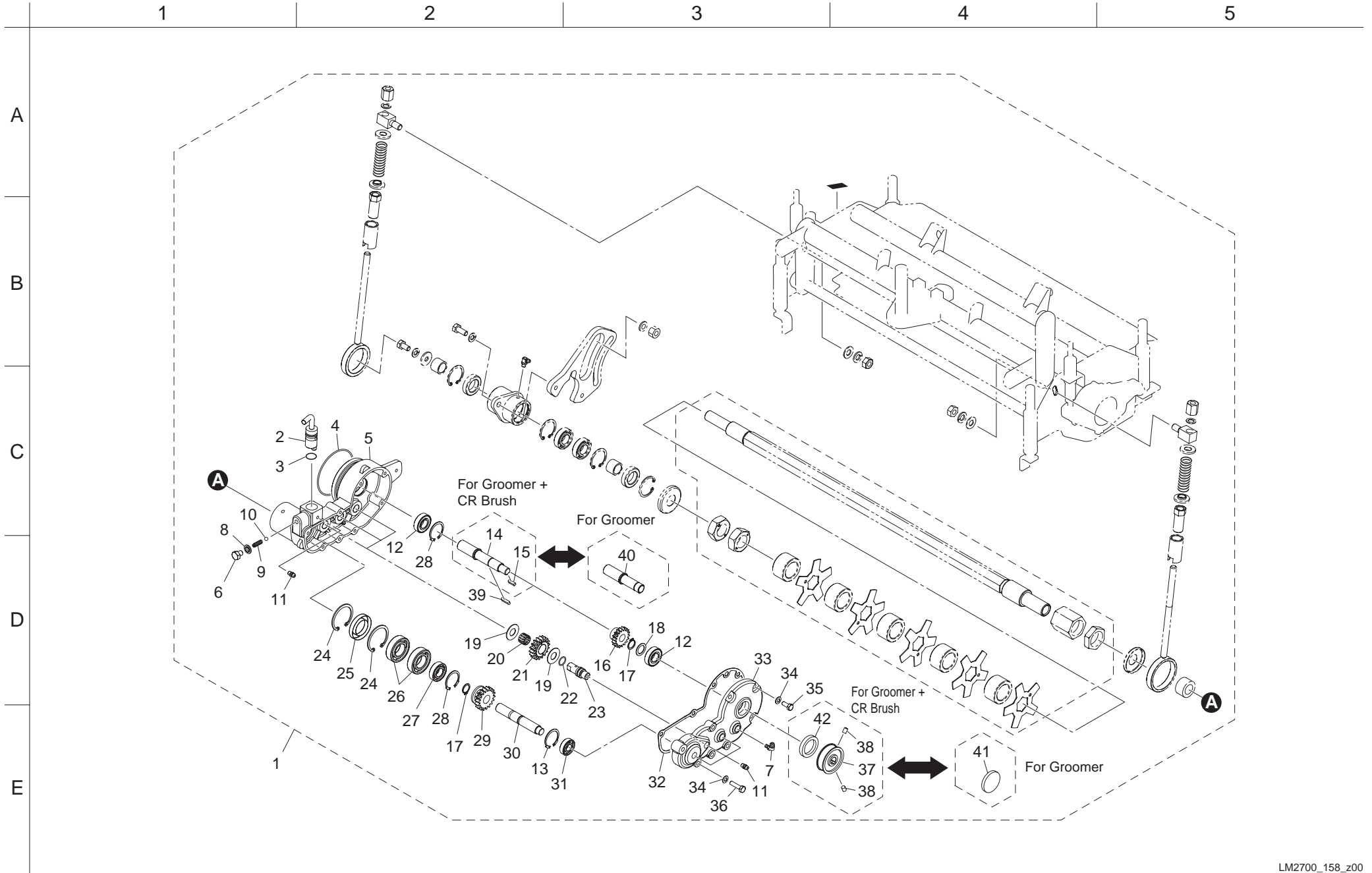

Cat No.	Code No.	Part name	Qty	Remark	SN of application	Cat No.	Code No.	Part name	Qty	Remark	SN of application
159-1	LH629R-1190Z0	GROOMER ASSY, RIGHT MOWER	2			159-36	K0000060252	BOLT, M6-25	10		
159-2	LH669R-1303Z8	LEVER, CLUTCH (L)	2			159-37	LM2700-4106Z2	PULLEY, DRIVING	2		
159-3	K0880015000	O-RING, P15	2			159-38	K0023050081	SETSCREW, M5-8	4		
159-4	K0885080000	O-RING, S80	2			159-39	K0500404180	KEY, BOTH ROUND M4-418	2		
159-5	LH669R-1301Z0	CASE, GROOMER (L)	2			159-40	LH669L-1101Z0	SHAFT, DRIVE	2		
159-6	K0000080102	BOLT, M8-10	2			159-41	K0890000030	CAP, BLANK 25	2		
159-7	K1440000020	GREASE NIPPLE, C	2			159-42	K0821525070	OIL SEAL, MHSA15257	2		
159-8	K0922080000	SEAL, WASHER 8WF	2								
159-9	K1000000090	SPRING, COMPRESSION M1-6-18	2								
159-10	K1500635000	BALL, STEEL 6.35	2								
159-11	K1440000010	GREASE NIPPLE, A TYPE	8								
159-12	K0612060020	BEARING, BALL SEAL 2RD 6002	4								
159-13	K0402028001	RING, RETAINING R M28	2								
159-14	LH669L-1304Z0	SHAFT, DRIVE	2								
159-15	K0520404140	KEY, ROUND/SQUARE, M4-414	2								
159-16	LH669L-1305Z0	GEAR, 17 TEETH	2								
159-17	K0401015001	RING, RETAINING S M15	4								
159-18	K5051015220	WASHER, C5191P 1-15-22	2								
159-19	K5051013280	WASHER, C5191P 1-13-28	12								
159-20	K0701317120	BEARING, NEEDLE CAGE KT 131712	6								
159-21	K6186000030	GEAR, 18 TEETH	6								
159-22	K0885014000	O-RING, S14	6								
159-23	LM2700-0111Z0	COUNTERSHAFT	6								
159-24	K0402045001	RING, RETAINING R M45	4								
159-25	K0822844080	OIL SEAL, MHSA28448	2								
159-26	K0600060220	BEARING, 60/22	4								
159-27	K0600060020	BEARING, 6002	2								
159-28	K0404032001	RING, RETAINING ROUND R M32	2								
159-29	LM2700-0110Z0	GEAR, CLUTCH 18 TEETH	2								
159-30	LH669L-1303Z0	SHAFT, SPLINE OUTPUT	2								
159-31	K0600006001	BEARING, BALL 6001	2								
159-32	LM2700-0129A0	PACKING, GROOMER	2								
159-33	LH669R-1302Z0	COVER, GROOMER (L)	2								
159-34	K0212060002	WASHER, DISK SPRING L M6-1	16								
159-35	K0000060152	BOLT, M6-15	6								

160. 26inch Groomer Ass'y section B for mower unit #2,#4 (Option)

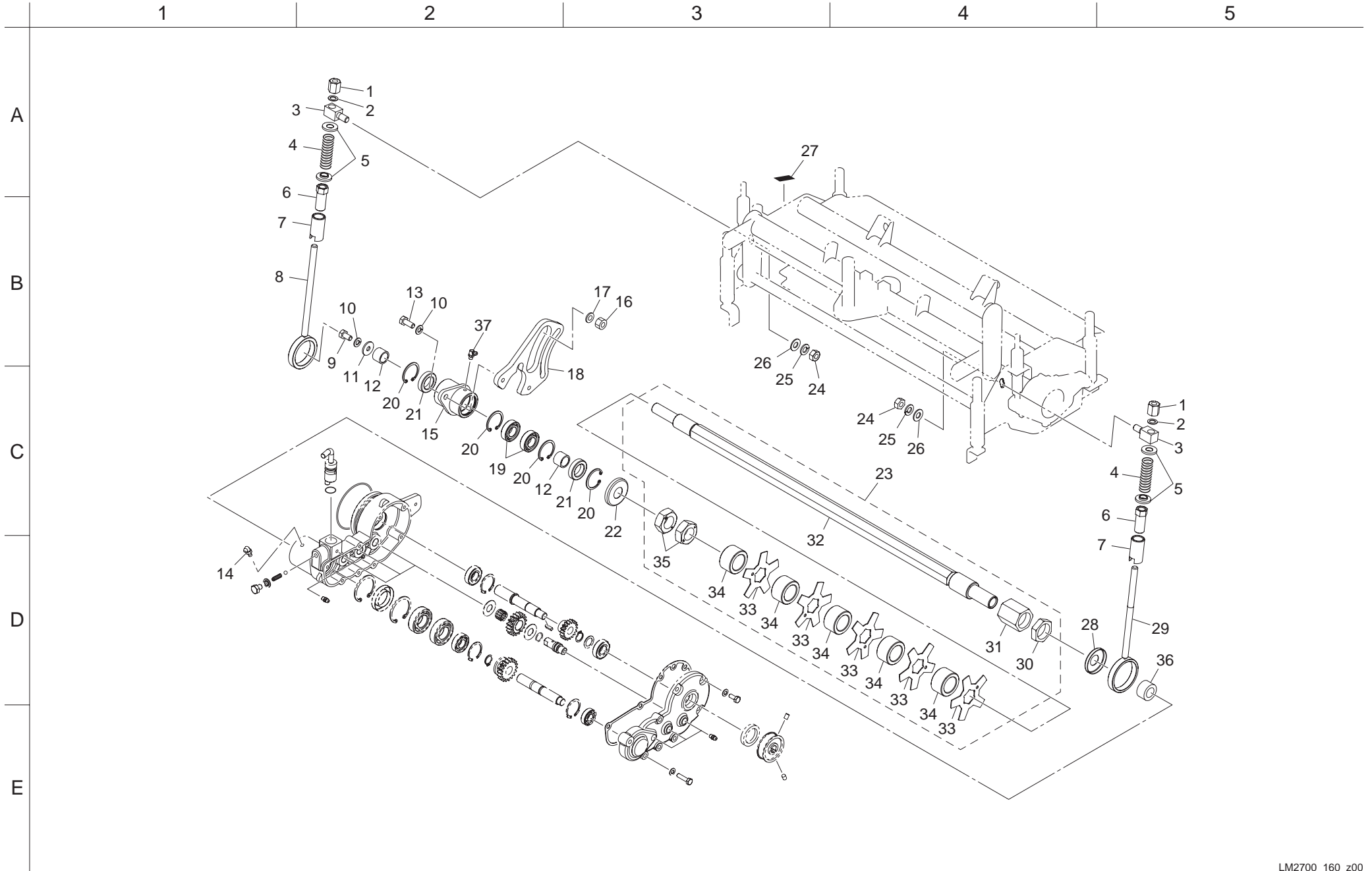

Cat No.	Code No.	Part name	Qty	Remark	SN of application	Cat No.	Code No.	Part name	Qty	Remark	SN of application
160-1	K0160000032	NUT, ADJUSTING BED-KNIFE P1 M10	4			160-36	K0737000090	RACE, INNER LRTZ 222818	2		
160-2	K5051010160	WASHER, C5191P 1-10-16	4			160-37	K1440000020	GREASE NIPPLE, C	2		
160-3	LM2700-0136Z2	RECEIVER, ROD 10	4								
160-4	K1000000578	SPRING, COMPRESSION M3.5-22-73	4								
160-5	K6206000052	RECEIVER , FOR SPRING	8								
160-6	LM535E-1335Z2	PIPE, WITH CUTTER ADJUSTING SCREW	4								
160-7	LM2700-0135Z2	PIPE, ADJUSTING	4								
160-8	LM2700-0134A2	BOLT, ADJUSTING GROOMER	2								
160-9	K0000080152	BOLT, M8-15	2								
160-10	K0200080002	WASHER, SPRING M8	6								
160-11	K5012308242	WASHER, SPCC 2.3-8-24	2								
160-12	K0737000060	CAGE, INNER FOR NB LRT172216	4								
160-13	K0000080202	BOLT, M8-20	4								
160-14	K1440000030	GREASE NIPPLE, B	2								
160-15	LH669R-1304Z2	HOUSING, GROOMER (R)	2								
160-16	K0144100002	NUT, WITH F-RING, M10	2								
160-17	K5073210242	WASHER, SPHC 3.2-10-24	2								
160-18	LH669L-1312Z2	BRACKET, GROOMER HOUSING	2								
160-19	K0600060030	BEARING, BALL 6003	4								
160-20	K0402035001	RING, RETAINING R M35	8								
160-21	K0822235080	OIL SEAL, MHSA22358	2								
160-22	K5370000312	COVER, DUST PROOF	2								
160-23	LH669L-1391Z0	SHAFT ASSY, GROOMER	2								
160-24	K0100100002	NUT, M10	4								
160-25	K0200100002	WASHER, SPRING M10	4								
160-26	K5000100002	WASHER, M10	4								
160-27	K4203000080	STICKER, ON/OFF	2								
160-28	LH669L-1310Z2	COVER, CASE DUST PROOF	2								
160-29	LH669L-1313Z2	BOLT, ADJUSTING GROOMER	2								
160-30	LH669L-1309Z2	NUT, SECURING (SMALL)	2								
160-31	LH669L-1308Z2	NUT, SECURING (LARGE)	2								
160-32	LH669L-1307Z2	SHAFT, GROOMER	2								
160-33	K2570000039	BLADE, VERTICAL 1.2-5-85	46								
160-34	K6214000020	COLLAR, AC M28-42-24.6	46								
160-35	K0108240002	NUT, P1.5 M24-3	4								

161. 22inch Groomer Ass'y section B for mower unit #2,#4 (Option)

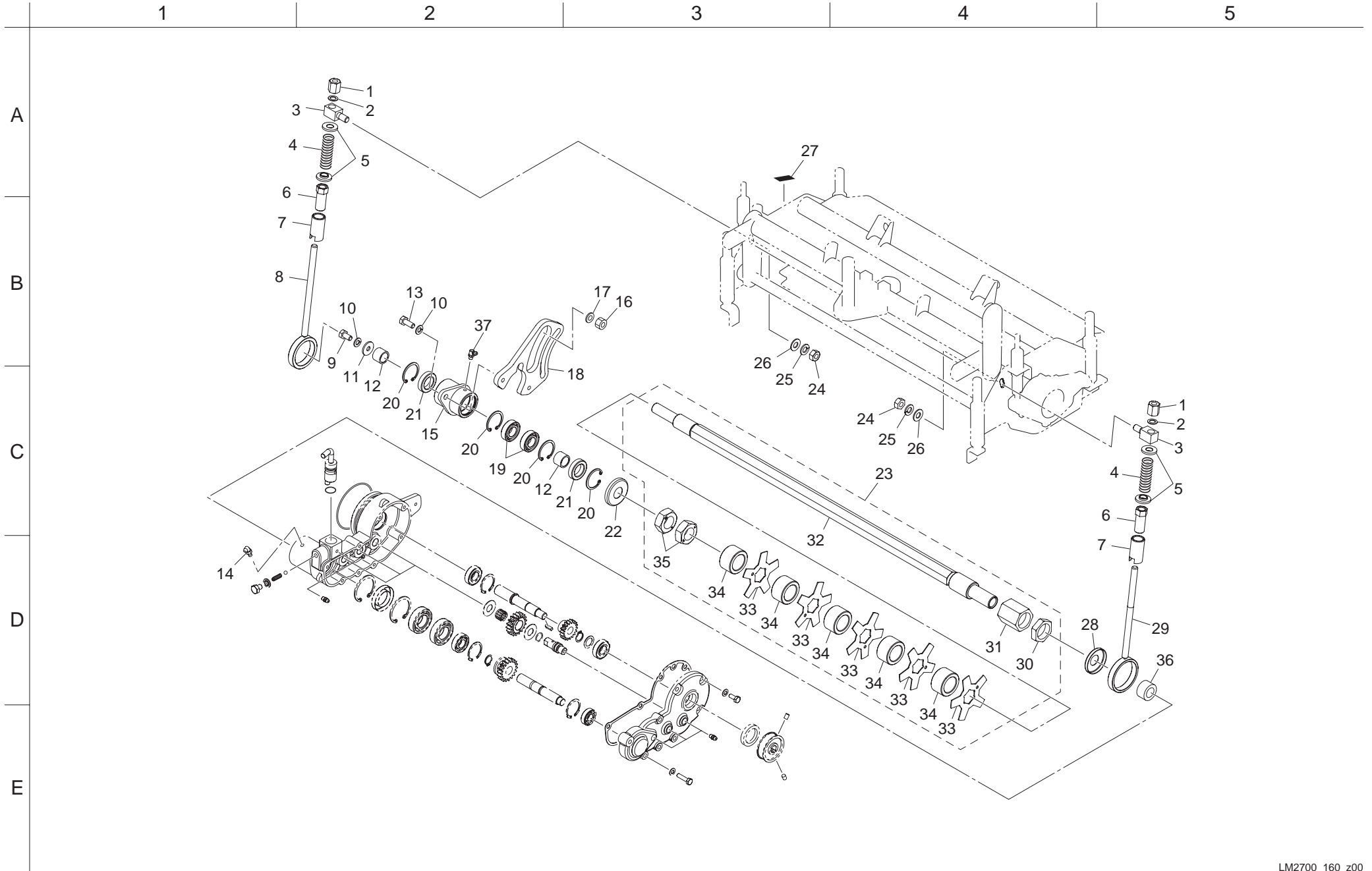

Cat No.	Code No.	Part name	Qty	Remark	SN of application	Cat No.	Code No.	Part name	Qty	Remark	SN of application
161-1	K0160000032	NUT, ADJUSTING BED-KNIFE P1 M10	4			161-36	K0737000090	RACE, INNER LRTZ 222818	2		
161-2	K5051010160	WASHER, C5191P 1-10-16	4			161-37	K1440000020	GREASE NIPPLE, C	2		
161-3	LM2700-0136Z2	RECEIVER, ROD 10	4								
161-4	K1000000578	SPRING, COMPRESSION M3.5-22-73	4								
161-5	K6206000052	RECEIVER , FOR SPRING	8								
161-6	LM535E-1335Z2	PIPE, WITH CUTTER ADJUSTING SCREW	4								
161-7	LM2700-0135Z2	PIPE, ADJUSTING	4								
161-8	LM2700-0134A2	BOLT, ADJUSTING GROOMER	2								
161-9	K0000080152	BOLT, M8-15	2								
161-10	K0200080002	WASHER, SPRING M8	6								
161-11	K5012308242	WASHER, SPCC 2.3-8-24	2								
161-12	K0737000060	CAGE, INNER FOR NB LRT172216	4								
161-13	K0000080202	BOLT, M8-20	4								
161-14	K1440000030	GREASE NIPPLE, B	2								
161-15	LH669R-1304Z2	HOUSING, GROOMER (R)	2								
161-16	K0144100002	NUT, WITH F-RING, M10	2								
161-17	K5073210242	WASHER, SPHC 3.2-10-24	2								
161-18	LH669L-1312Z2	BRACKET, GROOMER HOUSING	2								
161-19	K0600060030	BEARING, BALL 6003	4								
161-20	K0402035001	RING, RETAINING R M35	8								
161-21	K0822235080	OIL SEAL, MHSA22358	2								
161-22	K5370000312	COVER, DUST PROOF	2								
161-23	LH629L-1391Z0	SHAFT ASSY, GROOMER 22	2								
161-24	K0100100002	NUT, M10	4								
161-25	K0200100002	WASHER, SPRING M10	4								
161-26	K5000100002	WASHER, M10	4								
161-27	K4203000080	STICKER, ON/OFF	2								
161-28	LH669L-1310Z2	COVER, CASE DUST PROOF	2								
161-29	LH669L-1313Z2	BOLT, ADJUSTING GROOMER	2								
161-30	LH669L-1309Z2	NUT, SECURING (SMALL)	2								
161-31	LH669L-1308Z2	NUT, SECURING (LARGE)	2								
161-32	LH629L-1301Z2	SHAFT, GROOMER 22	2								
161-33	K2570000039	BLADE, VERTICAL 1.2-5-85	46								
161-34	K6214000020	COLLAR, AC M28-42-24.6	46								
161-35	K0108240002	NUT, P1.5 M24-3	4								

162. 26inch CR brush section for mower unit #1,#3,#5 (Option) (accompanied by groomer)

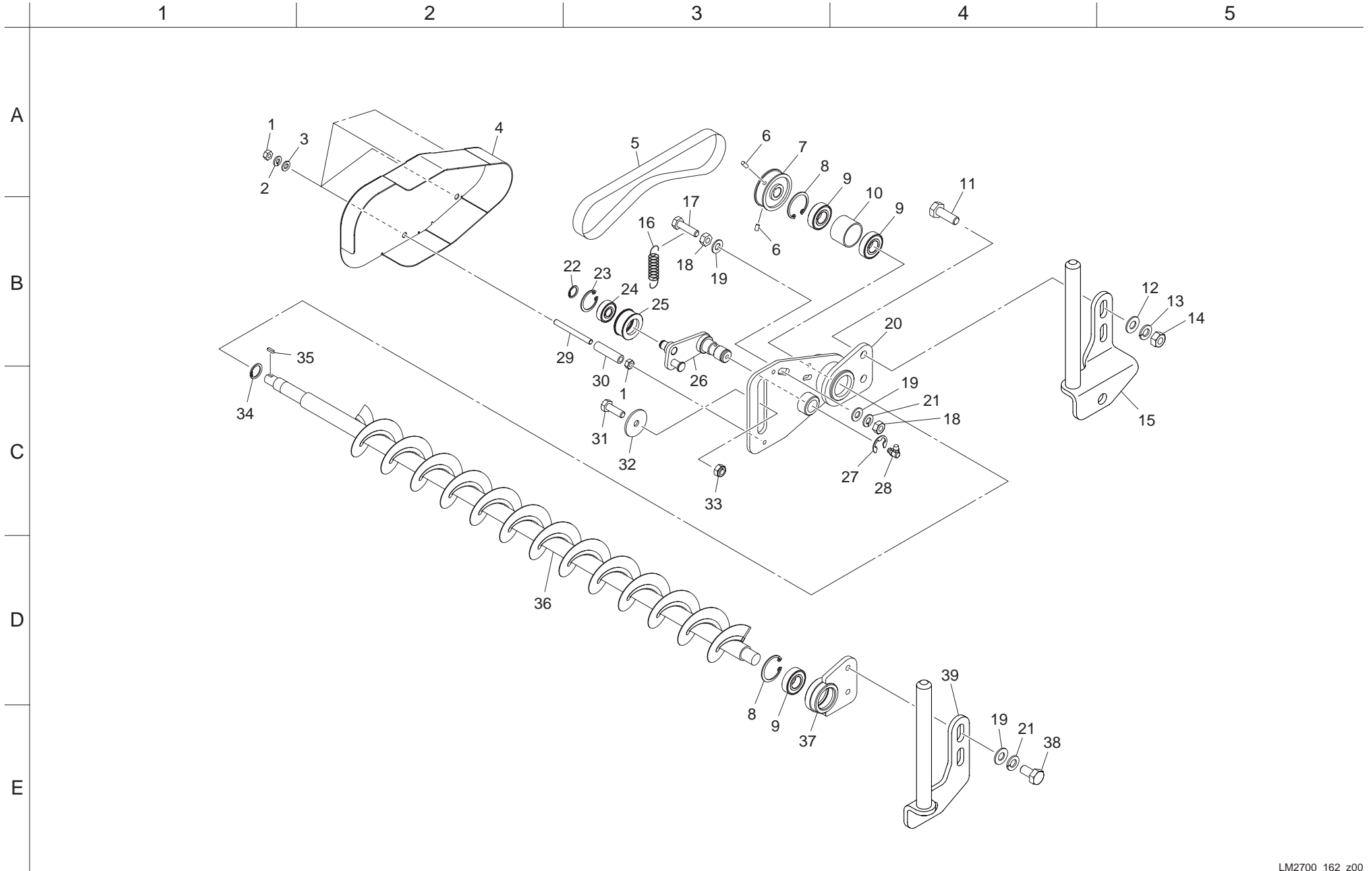

Cat No.	Code No.	Part name	Qty	Remark	SN of application	Cat No.	Code No.	Part name	Qty	Remark	SN of application
162-1	K0100060002	NUT, M6	24			162-36	LH669L-1321Z0	BRUSH, CR	3		
162-2	K0200060002	WASHER, SPRING M6	12			162-37	LH669L-1315ZD	HOUSING, BRUSH (L)	3		
162-3	K5000060002	WASHER, M6	12			162-38	K0000080202	BOLT, M8-20	6		
162-4	LH669L-1318ZD	COVER, CASE (R)	3			162-39	LH669L-0801Z2	SCREW, ADJUSTING CUTTING HEIGHT (L)	3		
162-5	K2380000030	BELT, 10FL-500	3								
162-6	K0023050081	SETSCREW, M5-8	6								
162-7	LM2700-4107Z2	PULLEY, BRUSH SHAFT	3								
162-8	K0402032001	RING, RETAINING R M32	6								
162-9	K0612060020	BEARING, BALL SEAL 2RD 6002	9								
162-10	LH669L-1317Z2	COLLAR, STKM 28.6-31.8-22	3								
162-11	K0000100302	BOLT, M10-30	6								
162-12	K5000100002	WASHER, M10	6								
162-13	K0200100002	WASHER, SPRING M10	6								
162-14	K0100100002	NUT, M10	6								
162-15	LH669L-0802Z2	SCREW, ADJUSTING CUTTING HEIGHT (R)	3								
162-16	K1020000208	SPRING, WITH ROUND HOOK M1.6-16.6-65.2	3								
162-17	K0000080302	BOLT, M8-30	3								
162-18	K0100080002	NUT, M8	6								
162-19	K5000080002	WASHER, M8	9								
162-20	LH669L-1314ZD	FRAME, BRUSH (R)	3								
162-21	K0200080002	WASHER, SPRING M8	9								
162-22	K0401010001	RING, RETAINING S M10	3								
162-23	K0402026001	RING, RETAINING R M26	3								
162-24	K0608060000	BEARING, BALL SEAL 2RS 6000	3								
162-25	LM2700-4108Z2	PULLEY, TENSION 1232	3								
162-26	LH669L-1316Z2	LEVER, TENSION (R)	3								
162-27	K0400012002	RING, RETAINING E M12	3								
162-28	K1440000020	GREASE NIPPLE, C	3								
162-29	LH669L-1319Z2	SHAFT, SCREWED 60	12								
162-30	LH669L-1320Z2	COLLAR, SPG 6.5-10.5-40	12								
162-31	K0000080252	BOLT, M8-25	3								
162-32	K5012308352	WASHER, SPCC 2.3-8-35	3								
162-33	K0144080002	NUT, WITH F-RING, M8	3								
162-34	K0401015001	RING, RETAINING S M15	3								
162-35	K0520404140	KEY, ROUND/SQUARE, M4-414	3								

163. 22inch CR brush section for mower unit #1,#3,#5 (Option) (accompanied by groomer)

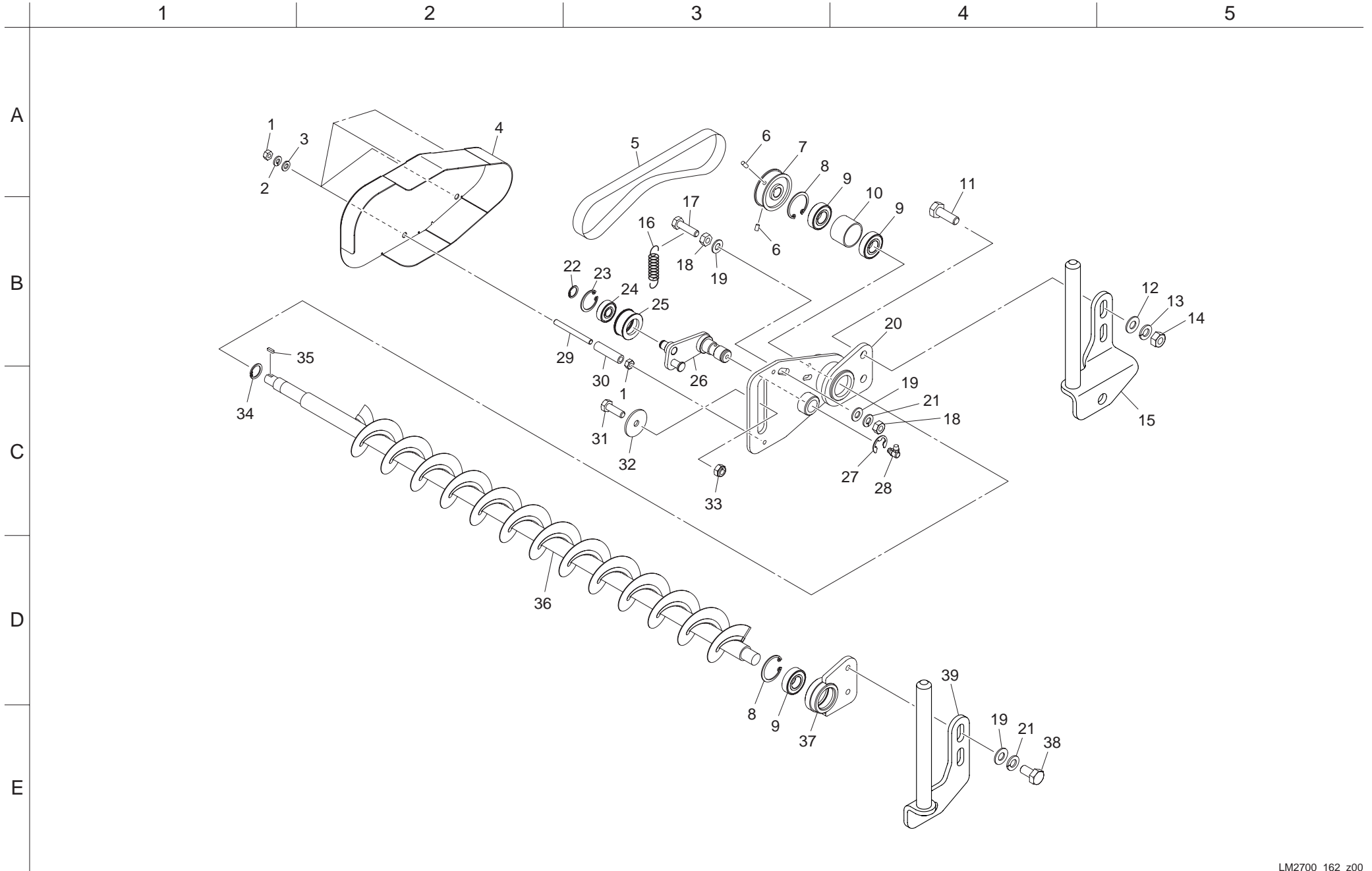

Cat No.	Code No.	Part name	Qty	Remark	SN of application	Cat No.	Code No.	Part name	Qty	Remark	SN of application
163-1	K0100060002	NUT, M6	24			163-36	LH629L-1302Z0	BRUSH, CR 22	3		
163-2	K0200060002	WASHER, SPRING M6	12			163-37	LH669L-1315ZD	HOUSING, BRUSH (L)	3		
163-3	K5000060002	WASHER, M6	12			163-38	K0000080202	BOLT, M8-20	6		
163-4	LH669L-1318ZD	COVER, CASE (R)	3			163-39	LH669L-0801Z2	SCREW, ADJUSTING CUTTING HEIGHT (L)	3		
163-5	K2380000030	BELT, 10FL-500	3								
163-6	K0023050081	SETSCREW, M5-8	6								
163-7	LM2700-4107Z2	PULLEY, BRUSH SHAFT	3								
163-8	K0402032001	RING, RETAINING R M32	6								
163-9	K0612060020	BEARING, BALL SEAL 2RD 6002	9								
163-10	LH669L-1317Z2	COLLAR, STKM 28.6-31.8-22	3								
163-11	K0000100302	BOLT, M10-30	6								
163-12	K5000100002	WASHER, M10	6								
163-13	K0200100002	WASHER, SPRING M10	6								
163-14	K0100100002	NUT, M10	6								
163-15	LH669L-0802Z2	SCREW, ADJUSTING CUTTING HEIGHT (R)	3								
163-16	K1020000208	SPRING, WITH ROUND HOOK M1.6-16.6-65.2	3								
163-17	K0000080302	BOLT, M8-30	3								
163-18	K0100080002	NUT, M8	6								
163-19	K5000080002	WASHER, M8	9								
163-20	LH669L-1314ZD	FRAME, BRUSH (R)	3								
163-21	K0200080002	WASHER, SPRING M8	9								
163-22	K0401010001	RING, RETAINING S M10	3								
163-23	K0402026001	RING, RETAINING R M26	3								
163-24	K0608060000	BEARING, BALL SEAL 2RS 6000	3								
163-25	LM2700-4108Z2	PULLEY, TENSION 1232	3								
163-26	LH669L-1316Z2	LEVER, TENSION (R)	3								
163-27	K0400012002	RING, RETAINING E M12	3								
163-28	K1440000020	GREASE NIPPLE, C	3								
163-29	LH669L-1319Z2	SHAFT, SCREWED 60	12								
163-30	LH669L-1320Z2	COLLAR, SPG 6.5-10.5-40	12								
163-31	K0000080252	BOLT, M8-25	3								
163-32	K5012308352	WASHER, SPCC 2.3-8-35	3								
163-33	K0144080002	NUT, WITH F-RING, M8	3								
163-34	K0401015001	RING, RETAINING S M15	3								
163-35	K0520404140	KEY, ROUND/SQUARE, M4-414	3								

164. 26inch CR brush section for mower unit #1,#3,#5 (Option)

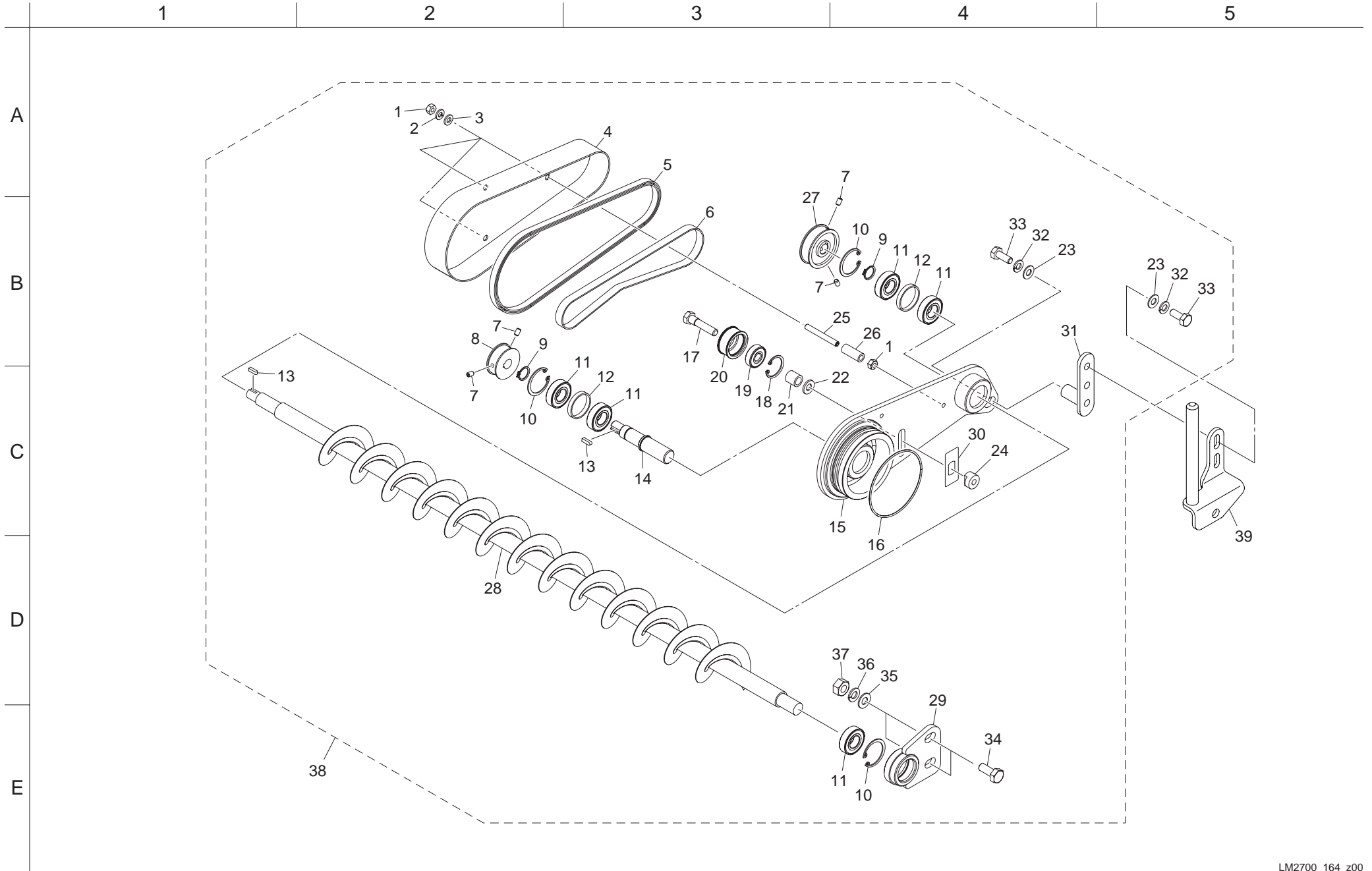

Cat No.	Code No.	Part name	Qty	Remark	SN of application	Cat No.	Code No.	Part name	Qty	Remark	SN of application
164-1	K0100060002	NUT, M6	18			164-36	K0200100002	WASHER, SPRING M10	6		
164-2	K0200060002	WASHER, SPRING M6	9			164-37	K0100100002	NUT, M10	6		
164-3	K5000060002	WASHER, M6	9			164-38	LH669L-1290Z0	BRUSH ASSY, CR (R)	3		
164-4	LM2700-4120ZD	COVER, BELT	3			164-39	LH669L-0802Z2	SCREW, ADJUSTING CUTTING HEIGHT (R)	3		
164-5	LM2700-4123Z0	RUBBER, 8U-615	3								
164-6	K2380000030	BELT, 10FL-500	3								
164-7	K0023050081	SETSCREW, M5-8	12								
164-8	LM2700-4106Z2	PULLEY, DRIVING	3								
164-9	K0401015001	RING, RETAINING S M15	6								
164-10	K0402032001	RING, RETAINING R M32	9								
164-11	K0612060020	BEARING, BALL SEAL 2RD 6002	15								
164-12	K6212004172	COLLAR, STKM M28.6-31.8-5	9								
164-13	K0520404140	KEY, ROUND/SQUARE, M4-414	6								
164-14	LM2700-4105Z0	SHAFT, DRIVING	3								
164-15	LH669L-1201ZD	FRAME, BRUSH (R)	3								
164-16	K0885080000	O-RING, S80	3								
164-17	LM2700-4111Z8	BOLT, SPECIAL M8	3								
164-18	K0402026001	RING, RETAINING R M26	3								
164-19	K0608006290	BEARING, BALL SEAL 2RS 629	3								
164-20	LM2700-4108Z2	PULLEY, TENSION 1232	3								
164-21	K6211000482	COLLAR, SGP M9.2-13.8-14	3								
164-22	K0213080002	WASHER, DISK SPRING H M8-1	3								
164-23	K5000080002	WASHER, M8	9								
164-24	LM2700-4109Z2	BASE, SCREW	3								
164-25	K0023060502	SETSCREW, M6-50	9								
164-26	K6211000492	COLLAR, SGP M6.5-10.5-26.4	9								
164-27	LM2700-4107Z2	PULLEY, BRUSH SHAFT	3								
164-28	LH669L-1203Z0	BRUSH, CR	3								
164-29	LH669L-1202ZD	HOUSING, BRUSH (L)	3								
164-30	LH669L-1206Z2	PLATE	3								
164-31	LH669L-1205ZD	ADJUSTER	3								
164-32	K0200080002	WASHER, SPRING M8	9								
164-33	K0000080152	BOLT, M8-15	9								
164-34	K0000100302	BOLT, M10-30	6								
164-35	K5000100002	WASHER, M10	6								

165. 22inch CR brush section for mower unit #1,#3,#5 (Option)

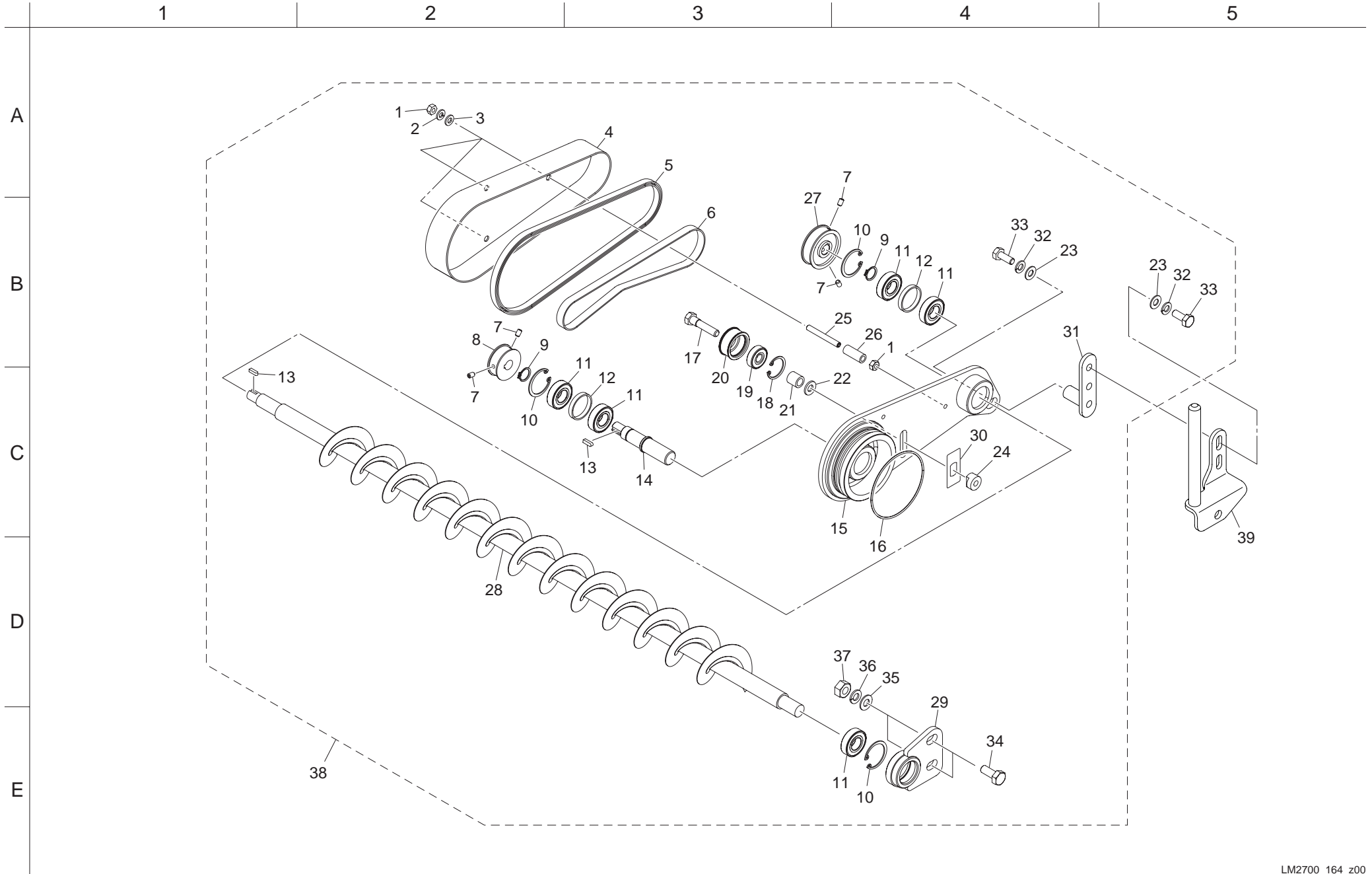

Cat No.	Code No.	Part name	Qty	Remark	SN of application	Cat No.	Code No.	Part name	Qty	Remark	SN of application
165-1	K0100060002	NUT, M6	18			165-36	K0200100002	WASHER, SPRING M10	6		
165-2	K0200060002	WASHER, SPRING M6	9			165-37	K0100100002	NUT, M10	6		
165-3	K5000060002	WASHER, M6	9			165-38	LH629L-1290Z0	CR BRUSH ASSY (R)	3		
165-4	LM2700-4120ZD	COVER, BELT	3			165-39	LH669L-0802Z2	SCREW, ADJUSTING CUTTING HEIGHT (R)	3		
165-5	LM2700-4123Z0	RUBBER, 8U-615	3								
165-6	K2380000030	BELT, 10FL-500	3								
165-7	K0023050081	SETSCREW, M5-8	12								
165-8	LM2700-4106Z2	PULLEY, DRIVING	3								
165-9	K0401015001	RING, RETAINING S M15	6								
165-10	K0402032001	RING, RETAINING R M32	9								
165-11	K0612060020	BEARING, BALL SEAL 2RD 6002	15								
165-12	K6212004172	COLLAR, STKM M28.6-31.8-5	9								
165-13	K0520404140	KEY, ROUND/SQUARE, M4-414	6								
165-14	LM2700-4105Z0	SHAFT, DRIVING	3								
165-15	LH669L-1201ZD	FRAME, BRUSH (R)	3								
165-16	K0885080000	O-RING, S80	3								
165-17	LM2700-4111Z8	BOLT, SPECIAL M8	3								
165-18	K0402026001	RING, RETAINING R M26	3								
165-19	K0608006290	BEARING, BALL SEAL 2RS 629	3								
165-20	LM2700-4108Z2	PULLEY, TENSION 1232	3								
165-21	K6211000482	COLLAR, SGP M9.2-13.8-14	3								
165-22	K0213080002	WASHER, DISK SPRING H M8-1	3								
165-23	K5000080002	WASHER, M8	9								
165-24	LM2700-4109Z2	BASE, SCREW	3								
165-25	K0023060502	SETSCREW, M6-50	9								
165-26	K6211000492	COLLAR, SGP M6.5-10.5-26.4	9								
165-27	LM2700-4107Z2	PULLEY, BRUSH SHAFT	3								
165-28	LH629L-1201Z0	BRUSH, CR 22	3								
165-29	LH669L-1202ZD	HOUSING, BRUSH (L)	3								
165-30	LH669L-1206Z2	PLATE	3								
165-31	LH669L-1205ZD	ADJUSTER	3								
165-32	K0200080002	WASHER, SPRING M8	9								
165-33	K0000080152	BOLT, M8-15	9								
165-34	K0000100302	BOLT, M10-30	6								
165-35	K5000100002	WASHER, M10	6								

166. 26inch CR brush section for mower unit #2,#4 (Option) (accompanied by groomer)

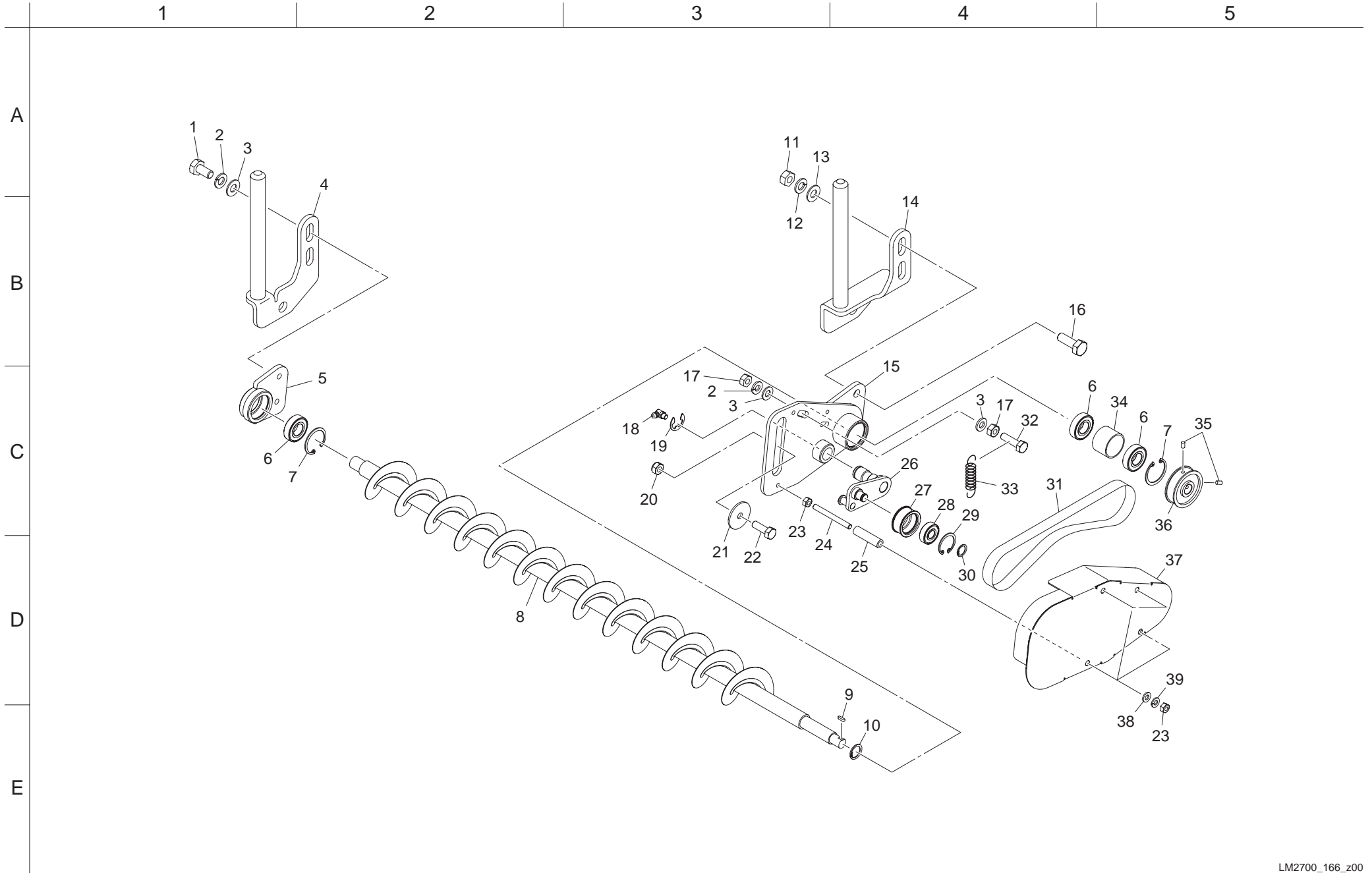

Cat No.	Code No.	Part name	Qty	Remark	SN of application	Cat No.	Code No.	Part name	Qty	Remark	SN of application
166-1	K0000080202	BOLT, M8-20	4			166-36	LM2700-4107Z2	PULLEY, BRUSH SHAFT	2		
166-2	K0200080002	WASHER, SPRING M8	6			166-37	LH669R-1309ZD	COVER, CASE (L)	2		
166-3	K5000080002	WASHER, M8	6			166-38	K5000060002	WASHER, M6	8		
166-4	LH669R-0801Z2	SCREW, ADJUSTING CUTTING HEIGHT (R)	2			166-39	K0200060002	WASHER, SPRING M6	8		
166-5	LH669R-1307ZD	HOUSING, BRUSH (R)	2								
166-6	K0612060020	BEARING, BALL SEAL 2RD 6002	6								
166-7	K0402032001	RING, RETAINING R M32	4								
166-8	LH669L-1321Z0	BRUSH, CR	2								
166-9	K0520404140	KEY, ROUND/SQUARE, M4-414	2								
166-10	K0401015001	RING, RETAINING S M15	2								
166-11	K0100100002	NUT, M10	4								
166-12	K0200100002	WASHER, SPRING M10	4								
166-13	K5000100002	WASHER, M10	4								
166-14	LH669R-0802Z2	SCREW, ADJUSTING CUTTING HEIGHT (L)	2								
166-15	LH669R-1306ZD	FRAME, BRUSH (L)	2								
166-16	K0000100302	BOLT, M10-30	4								
166-17	K0100080002	NUT, M8	4								
166-18	K1440000020	GREASE NIPPLE, C	2								
166-19	K0400012002	RING, RETAINING E M12	2								
166-20	K0144080002	NUT, WITH F-RING, M8	2								
166-21	K5012308352	WASHER, SPCC 2.3-8-35	2								
166-22	K0000080252	BOLT, M8-25	2								
166-23	K0100060002	NUT, M6	16								
166-24	LH669L-1319Z2	SHAFT, SCREWED 60	8								
166-25	LH669L-1320Z2	COLLAR, SPG 6.5-10.5-40	8								
166-26	LH669R-1308Z2	LEVER, TENSION (L)	2								
166-27	LM2700-4108Z2	PULLEY, TENSION 1232	2								
166-28	K0608060000	BEARING, BALL SEAL 2RS 6000	2								
166-29	K0402026001	RING, RETAINING R M26	2								
166-30	K0401010001	RING, RETAINING S M10	2								
166-31	K2380000030	BELT, 10FL-500	2								
166-32	K0000080302	BOLT, M8-30	2								
166-33	K1020000208	SPRING, WITH ROUND HOOK M1.6-16.6-65.2	2								
166-34	LH669L-1317Z2	COLLAR, STKM 28.6-31.8-22	2								
166-35	K0023050081	SETSCREW, M5-8	4								

167. 22inch CR brush section for mower unit #2,#4 (Option) (accompanied by groomer)

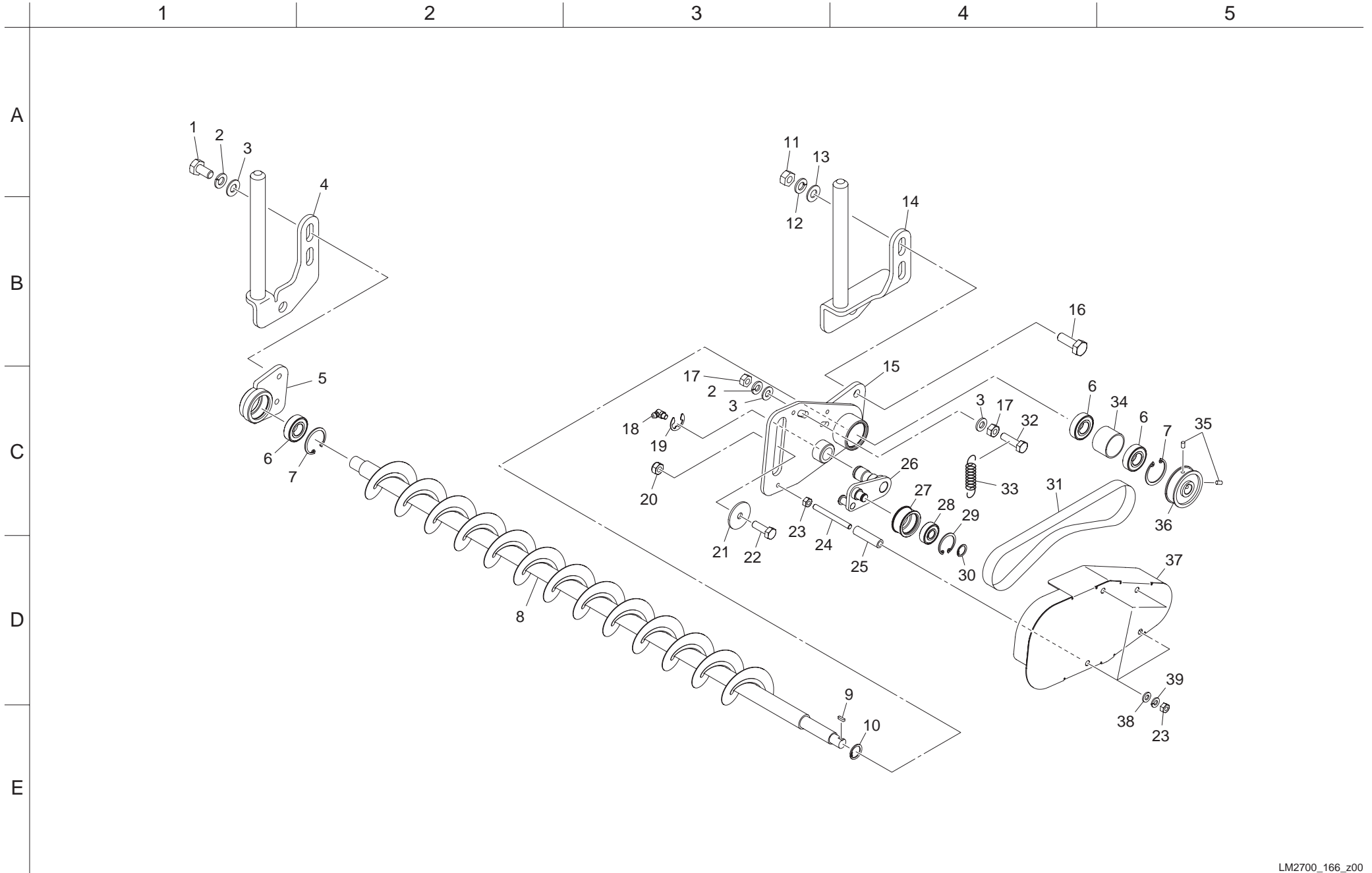

Cat No.	Code No.	Part name	Qty	Remark	SN of application	Cat No.	Code No.	Part name	Qty	Remark	SN of application
167-1	K0000080202	BOLT, M8-20	4			167-36	LM2700-4107Z2	PULLEY, BRUSH SHAFT	2		
167-2	K0200080002	WASHER, SPRING M8	6			167-37	LH669R-1309ZD	COVER, CASE (L)	2		
167-3	K5000080002	WASHER, M8	6			167-38	K5000060002	WASHER, M6	8		
167-4	LH669R-0801Z2	SCREW, ADJUSTING CUTTING HEIGHT (R)	2			167-39	K0200060002	WASHER, SPRING M6	8		
167-5	LH669R-1307ZD	HOUSING, BRUSH (R)	2								
167-6	K0612060020	BEARING, BALL SEAL 2RD 6002	6								
167-7	K0402032001	RING, RETAINING R M32	4								
167-8	LH629L-1302Z0	BRUSH, CR 22	2								
167-9	K0520404140	KEY, ROUND/SQUARE, M4-414	2								
167-10	K0401015001	RING, RETAINING S M15	2								
167-11	K0100100002	NUT, M10	4								
167-12	K0200100002	WASHER, SPRING M10	4								
167-13	K5000100002	WASHER, M10	4								
167-14	LH669R-0802Z2	SCREW, ADJUSTING CUTTING HEIGHT (L)	2								
167-15	LH669R-1306ZD	FRAME, BRUSH (L)	2								
167-16	K0000100302	BOLT, M10-30	4								
167-17	K0100080002	NUT, M8	4								
167-18	K1440000020	GREASE NIPPLE, C	2								
167-19	K0400012002	RING, RETAINING E M12	2								
167-20	K0144080002	NUT, WITH F-RING, M8	2								
167-21	K5012308352	WASHER, SPCC 2.3-8-35	2								
167-22	K0000080252	BOLT, M8-25	2								
167-23	K0100060002	NUT, M6	16								
167-24	LH669L-1319Z2	SHAFT, SCREWED 60	8								
167-25	LH669L-1320Z2	COLLAR, SPG 6.5-10.5-40	8								
167-26	LH669R-1308Z2	LEVER, TENSION (L)	2								
167-27	LM2700-4108Z2	PULLEY, TENSION 1232	2								
167-28	K0608060000	BEARING, BALL SEAL 2RS 6000	2								
167-29	K0402026001	RING, RETAINING R M26	2								
167-30	K0401010001	RING, RETAINING S M10	2								
167-31	K2380000030	BELT, 10FL-500	2								
167-32	K0000080302	BOLT, M8-30	2								
167-33	K1020000208	SPRING, WITH ROUND HOOK M1.6-16.6-65.2	2								
167-34	LH669L-1317Z2	COLLAR, STKM 28.6-31.8-22	2								
167-35	K0023050081	SETSCREW, M5-8	4								

168. 26inch CR brush section for mower unit #2,#4 (Option)

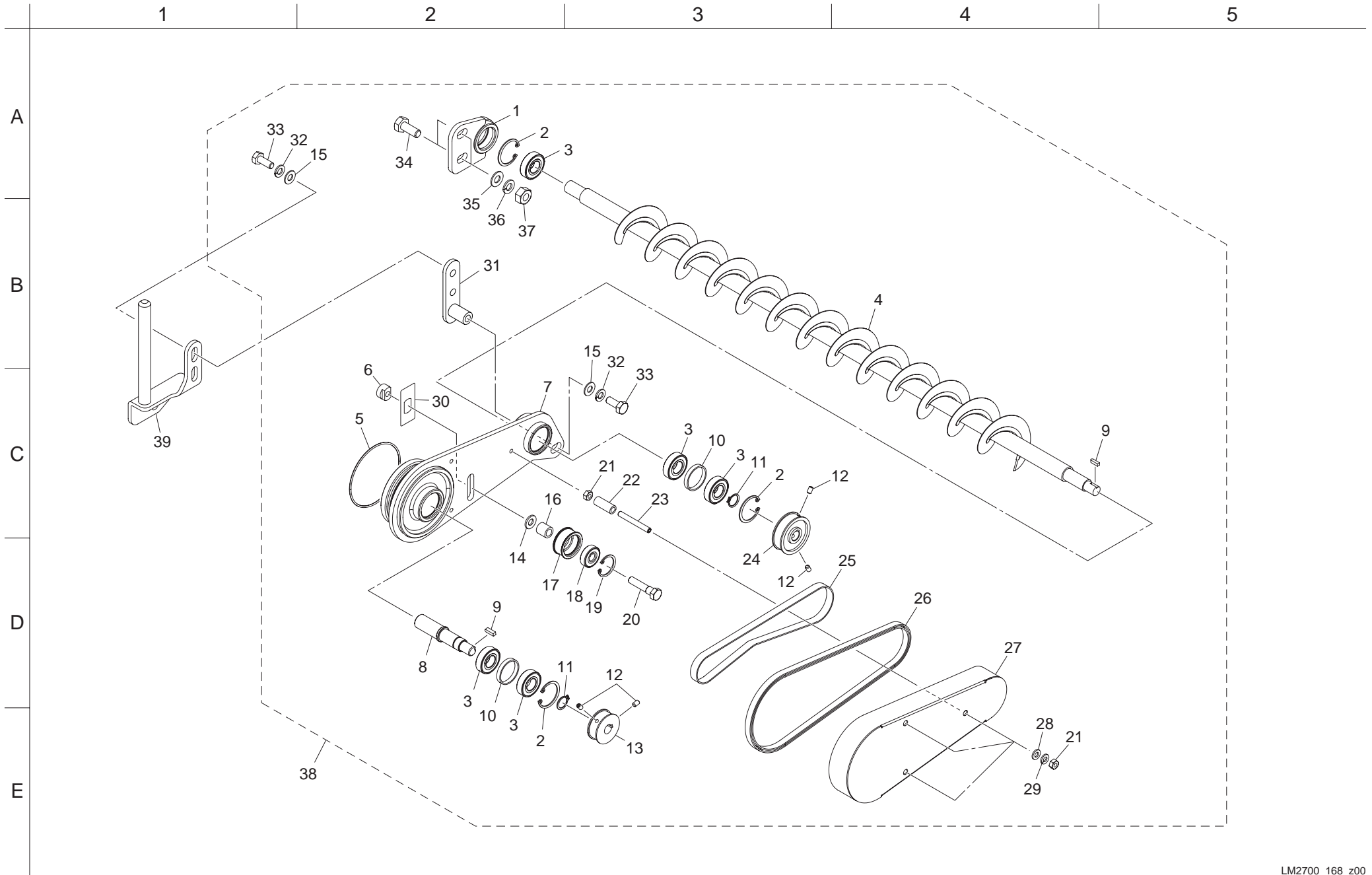

Cat No.	Code No.	Part name	Qty	Remark	SN of application	Cat No.	Code No.	Part name	Qty	Remark	SN of application
168-1	LH669R-1202ZD	HOUSING, BRUSH (R)	2			168-36	K0200100002	WASHER, SPRING M10	6		
168-2	K0402032001	RING, RETAINING R M32	6			168-37	K0100100002	NUT, M10	6		
168-3	K0612060020	BEARING, BALL SEAL 2RD 6002	10			168-38	LH669R-1290Z0	BRUSH ASSY, CR (L)	2		
168-4	LH669L-1203Z0	BRUSH, CR	2			168-39	LH669R-0802Z2	SCREW, ADJUSTING CUTTING HEIGHT (L)	2		
168-5	K0885080000	O-RING, S80	2								
168-6	LM2700-4109Z2	BASE, SCREW	2								
168-7	LH669R-1201ZD	FRAME, BRUSH (L)	2								
168-8	LM2700-4105Z0	SHAFT, DRIVING	2								
168-9	K0520404140	KEY, ROUND/SQUARE, M4-414	4								
168-10	K6212004172	COLLAR, STKM M28.6-31.8-5	6								
168-11	K0401015001	RING, RETAINING S M15	4								
168-12	K0023050081	SETSCREW, M5-8	8								
168-13	LM2700-4106Z2	PULLEY, DRIVING	2								
168-14	K0213080002	WASHER, DISK SPRING H M8-1	2								
168-15	K5000080002	WASHER, M8	6								
168-16	K6211000482	COLLAR, SGP M9.2-13.8-14	2								
168-17	LM2700-4108Z2	PULLEY, TENSION 1232	2								
168-18	K0608006290	BEARING, BALL SEAL 2RS 629	2								
168-19	K0402026001	RING, RETAINING R M26	2								
168-20	LM2700-4111Z8	BOLT, SPECIAL M8	2								
168-21	K0100060002	NUT, M6	12								
168-22	K6211000492	COLLAR, SGP M6.5-10.5-26.4	6								
168-23	K0023060502	SETSCREW, M6-50	6								
168-24	LM2700-4107Z2	PULLEY, BRUSH SHAFT	2								
168-25	K2380000030	BELT, 10FL-500	2								
168-26	LM2700-4123Z0	RUBBER, 8U-615	2								
168-27	LM2700-4120ZD	COVER, BELT	2								
168-28	K5000060002	WASHER, M6	6								
168-29	K0200060002	WASHER, SPRING M6	6								
168-30	LH669L-1206Z2	PLATE	2								
168-31	LH669L-1205ZD	ADJUSTER	3								
168-32	K0200080002	WASHER, SPRING M8	9								
168-33	K0000080152	BOLT, M8-15	9								
168-34	K0000100302	BOLT, M10-30	6								
168-35	K5000100002	WASHER, M10	6								

169. 22inch CR brush section for mower unit #2,#4 (Option)

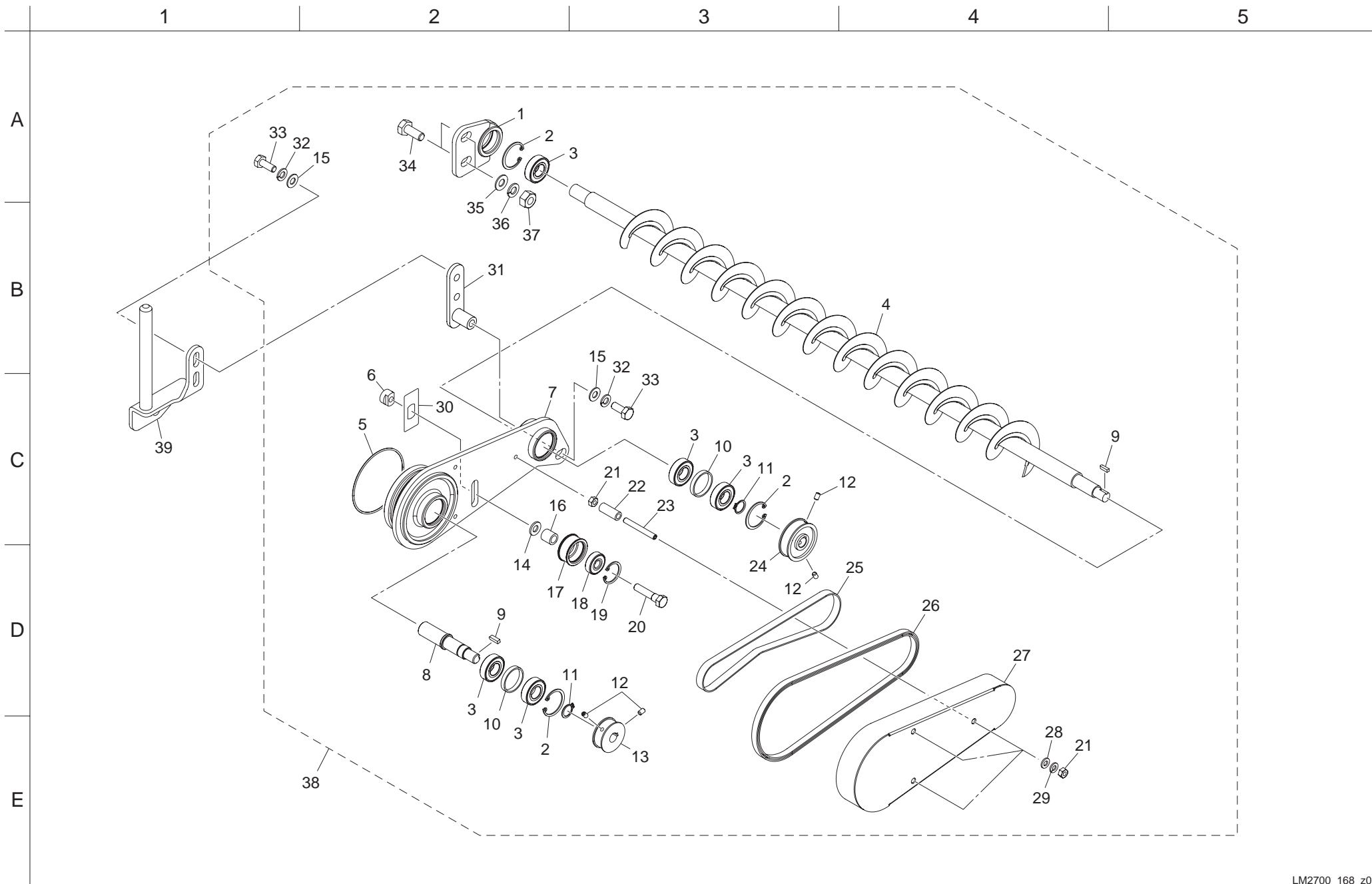

Cat No.	Code No.	Part name	Qty	Remark	SN of application	Cat No.	Code No.	Part name	Qty	Remark	SN of application
169-1	LH669R-1202ZD	HOUSING, BRUSH (R)	2			169-36	K0200100002	WASHER, SPRING M10	6		
169-2	K0402032001	RING, RETAINING R M32	6			169-37	K0100100002	NUT, M10	6		
169-3	K0612060020	BEARING, BALL SEAL 2RD 6002	10			169-38	LH629R-1290Z0	CR BRUSH ASSY (L)	2		
169-4	LH629L-1302Z0	BRUSH, CR 22	2			169-39	LH669R-0802Z2	SCREW, ADJUSTING CUTTING HEIGHT (L)	2		
169-5	K0885080000	O-RING, S80	2								
169-6	LM2700-4109Z2	BASE, SCREW	2								
169-7	LH669R-1201ZD	FRAME, BRUSH (L)	2								
169-8	LM2700-4105Z0	SHAFT, DRIVING	2								
169-9	K0520404140	KEY, ROUND/SQUARE, M4-414	4								
169-10	K6212004172	COLLAR, STKM M28.6-31.8-5	6								
169-11	K0401015001	RING, RETAINING S M15	4								
169-12	K0023050081	SETSCREW, M5-8	8								
169-13	LM2700-4106Z2	PULLEY, DRIVING	2								
169-14	K0213080002	WASHER, DISK SPRING H M8-1	2								
169-15	K5000080002	WASHER, M8	6								
169-16	K6211000482	COLLAR, SGP M9.2-13.8-14	2								
169-17	LM2700-4108Z2	PULLEY, TENSION 1232	2								
169-18	K0608006290	BEARING, BALL SEAL 2RS 629	2								
169-19	K0402026001	RING, RETAINING R M26	2								
169-20	LM2700-4111Z8	BOLT, SPECIAL M8	2								
169-21	K0100060002	NUT, M6	12								
169-22	K6211000492	COLLAR, SGP M6.5-10.5-26.4	6								
169-23	K0023060502	SETSCREW, M6-50	6								
169-24	LM2700-4107Z2	PULLEY, BRUSH SHAFT	2								
169-25	K2380000030	BELT, 10FL-500	2								
169-26	LM2700-4123Z0	RUBBER, 8U-615	2								
169-27	LM2700-4120ZD	COVER, BELT	2								
169-28	K5000060002	WASHER, M6	6								
169-29	K0200060002	WASHER, SPRING M6	6								
169-30	LH669L-1206Z2	PLATE	2								
169-31	LH669L-1205ZD	ADJUSTER	3								
169-32	K0200080002	WASHER, SPRING M8	9								
169-33	K0000080152	BOLT, M8-15	9								
169-34	K0000100302	BOLT, M10-30	6								
169-35	K5000100002	WASHER, M10	6								

BARONESS[®]
Quality on Demand



KYOEISHA CO.,LTD.

Head Office 1-26, Miyuki-cho, Toyokawa, Tel : (0533)84-1390
Aichi-Pref. 442-8530 Japan. Fax : (0533)89-3623