



TRU-TURF

RS48-11C USA GOLF ROLLER & SPIKER MANUAL

Contents

1. Important
2. Machine Information Record
3. Safety Information
4. Warranty
5. Assembly
8. Operation
10. Maintenance
12. Fault Finding
13. Machine Components
25. Options
26. Labels
27. Parts List

Note: Separate Engine Owners Manual Included

THE 1/2" SIZE FOR THE STEER & SMOOTHING HEAD CONNECTING RODS AND STEER ARM APPLIES FROM SERIAL NUMBER R10923 TO R11557 INCLUSIVE

A NEW DESIGN SMOOTHING ROLLER R8217 IS AVAILABLE TO REPLACE BOTH R8021 & R8290 TYPES.



Important

Please read and understand before operating machine.

1. Pre-check all nuts, bolts, grub screws for tightness prior to operating machine.
2. Understand the operating procedures and the controls before operating.
3. Use the machine to roll **18-36 greens** then **check** that all nuts, bolts etc. are tight. If loose and the Loctite seal has been broken, treat item as per Loctite instructions, reseal, then tighten securely.
4. **Loose transmission and drive roller sprockets will cause damage to shafts and keyways. Ensure they are correctly tightened at all times.**
5. **Change the transmission oil after 50 hours of operation, then as per the servicing schedule.**

We use and recommend Penrite Synthetic 5 SAE 5W-60. Available through our dealer network.

U.S.A. customers contact your dealer or visit www.truturf.com to find your nearest dealer.

Australian customers call 07 5594 7199.

International customers contact your dealer or visit www.truturf.com to find your nearest dealer.

Machine Information Record

Congratulations on your investment in the RS48-11C Roll 'n' Spike Golf Green Roller and your move to smoother, faster, more consistent putting Greens. The following operation and maintenance manual has been prepared for use with the RS48-11C Roll 'n' Spike Golf Green Roller. It is intended as a guide and supplemental updates to the manual may take place at a future date, without prior notice.

This machine is engineered to be simple to operate and easy to maintain. If you have any questions or concerns that this manual does not address, please feel free to contact your distributor.

Distributor Information

Name: _____

Address: _____

Telephone: _____

Fax: _____

Email: _____

Machine Information

Model. RS48-11C Roll 'n' Spike Golf Green Roller

Serial No. _____

Engine No. _____

Transmission No. _____

Purchase Date No. _____

Safety Information

Safety Information

Safety is of the utmost importance when operating turf equipment.

To ensure safe operation of the RS48-11C RS48-11C Roll 'n' Spike Golf Green Roller, please follow the following safety guidelines.

- Always make a pre-operation inspection before you start the engine. If this procedure is not carried out damage to property or personnel may occur.
- Keep children, pets and inexperienced personnel away from the machine. This machine should only be operated by trained and skilled personnel - check with your supervisor if you are unsure.
- Know how to stop the engine when in motion. Read and understand engine manufacturers manual, as supplied.
- Never permit inexperienced operators to use the machine. This machine requires certain knowledge and expertise to operate it; you must be a trained person to use this machine. Unskilled persons can harm themselves and others if they operate this machine.
- Do not use in enclosed areas unless well ventilated. Carbon monoxide gases are dangerous if inhaled, it can cause death; use the machine outdoors.
- When transporting the roller, make sure the trailer lock down mechanism is secure to prevent premature release of the catch. If the trailer catch is not correctly engaged while towing and releases accidentally, the front of the roller can drop and dig into the ground, causing the machine to move dangerously in any direction causing bodily injury. When carrying out maintenance ensure the catch is engaged correctly; if it is not the trailer arm could fly up making contact

with a person(s) causing serious injury.

- When engine is running, always keep hands and loose clothing away from rotating shafts, chains and sprockets in the transmission area. If hair, clothing or loose objects become entangled on a rotating shaft serious bodily injury could occur. Stop engine before opening safety cover fitted to the transmission area.
- Never ride on the machine when machine is being towed.

Operator, remember it is your responsibility to be aware of your surroundings. To avoid accidents, think safe and operate safe.

Five (5) Year Warranty

Universal Conditions:

Tru-Turf Pty. Ltd. will either repair or replace any item or part of a Tru-Turf Pty. Ltd. Golf Greens Roller that is defective in workmanship or material for a period of **sixty (60) months** from the date of delivery of the new product to the original end user. These items will be repaired or replaced free of charge and freight free.

Products Protected By This Warranty:

This Warranty relates to the following products manufactured by Tru-Turf Pty. Ltd. :-

GR7000C; GR11000C; RS48-11C; R52-11T and R52-ELT Golf Greens Rollers.

TR66 Triplex roll 'n' spike mower attachment heads and brackets; SR72 Sports ground roller.

MT5000-1, MT5000-2 and MT5000-3 Totes are covered for a period of twelve (12) months.

Parts Warranted By Suppliers To Tru-Turf:

Specific component parts supplied to Tru-Turf Pty. Ltd. are covered by that supplier's Warranty. These parts include Eaton Transmission, Honda Engines and Kohler Engines.

Only Tru-Turf Pty. Ltd. manufactured parts qualify for the the Sixty month warranty.

Normal Wear and Tear:

Tru-Turf Pty. Ltd. will not repair or replace parts subject to normal maintenance routines as specified in the products Operator's Manual nor to parts subject to wear and tear during the correct operation of the product. These parts include, but are not limited to, oils, filters, tyres, shafts, bearings, blades, spikers, slicers, brakes, belts, hoses, spark plugs, drive chains and sprockets.

Other Items Not Covered By This Warranty:

Tru-Turf Pty. Ltd. will not repair or replace free-of-charge any item that has been damaged by accident, lack of reasonable care and protection or lack of suitable storage. We will not cover parts that have been altered or modified by anyone other than Tru-Turf Pty. Ltd. nor will we cover used parts that are installed in place of failed parts. We will not cover parts that have not been installed correctly by the end user or its agents nor will we cover parts that have not been maintained as per the Operator's Manual. Service calls and overtime-labour rates will not be covered. We will not cover freight costs related to the return of the faulty product to Tru-Turf Pty. Ltd. or its agents. Tru-Turf Pty. Ltd. will not be liable for any consequential loss or damage or costs caused by or incidental to the failure of any new part supplied with the original purchase or any new part supplied as a replacement for any failed part.

Lodging Warranty Claims:

The final purchaser of the new Tru-Turf Pty. Ltd. product must lodge a Warranty Claim with Tru-Turf Pty. Ltd. or its agents. The original purchaser must provide written evidence detailing the product's delivery date to that purchaser and the reasons why the purchaser believes that the product or its part is defective in the categories of faulty material or workmanship. The purchaser is to deliver the faulty product or part to Tru-Turf Pty. Ltd. or its agents at the purchaser's expense. Acceptance or rejection of the Warranty Claim is entirely at the discretion of Tru-Turf Pty. Ltd. or their Suppliers who warrant their own part/s.

Visit www.truturf.com. Fill out the warranty form and return it to warranty@truturf.com

No person or organisation has the authority to modify the terms or conditions or limitations of this Warranty without the written consent of Tru-Turf Pty. Ltd.

Assembly

Initial Assembly

When you receive the crate, the machine will be broken down into components ready for assembly. If you run into any problems during assembly, please feel free to call your local distributor or agent.

List of Components

QTY	Description
1	Operation, Maintenance and Parts Manual
1	Machine Frame/Body
1	Drivers Seat
2	Armrests
4	$\frac{5}{16}$ " x $\frac{3}{4}$ " UNC Bolts (Seat)
2	Tires mounted on Wheel Rim
1	Steering Joystick
1	Dampener Strut (attached to main body end)
1	Left-side Trailer Arm
1	Right-side Trailer Arm
2	25mm External Circlips
1	Drawbar Coupling Assembly
2	$2\frac{1}{2}$ " x $\frac{3}{8}$ " UNF Hex Head Bolts (Drawbar)
2	$\frac{3}{8}$ " UNF Nyloc Nuts (Drawbar)

Assembly

Assembly Procedure

Step 1: Mounting the seat to the seat base.

- Use the four $\frac{5}{16}$ " x $\frac{3}{4}$ " UNC bolts to fasten the seat to the seat base.
- Remove armrest screws from the seat, position left and right side armrest, fasten and tighten.

Step 2: Mount the steering joystick to the steering shaft.

- Select the steering joystick.
- Remove the two bolts in the top of the steering shaft.
- Slide the joystick into the slot on the top of the steering shaft, already installed in the steering column directly in front of the foot pedal controls, insert the $\frac{3}{8}$ " bolt into the bottom bolt hole, select a comfortable operating position, joystick forward for extra operating room or back for less, once determined insert the other $\frac{3}{8}$ " bolt into the upper hole and tighten both bolts securely.

Step 3: Attaching the left-hand trailer arm to machine body.

- Locate the trailer arm support axle 25mm in diameter (1") which extends out on the left side of the machine, remove the circlip from the support axle. Oil machined portion. Slide the left hand side trailer arm, onto the axle, replace the circlip, ensuring the circlip is located in the groove correctly.

Step 4: Attaching dampener strut and right hand trailer arm.

- Locate the trailer arm support axle 25mm in diameter (1") which extends out on the right side of the machine, remove the circlip from the axle. Hold the right side trailer arm in the vertical position and slide it part way onto the axle. Locate dampener strut, remove packing from the unattached end.
- Apply thread lock "Loctite" to the M10 bolt attached to the dampener strut. Screw the M10 bolt into the strut support on the trailer arm.
- If necessary use a soft headed hammer and tap the trailer arm onto the axle until the circlip groove is revealed, fit the circlip, ensuring it is located in the groove correctly.

Step 5: Attaching draw bar to trailer arms.

- Locate the draw bar assembly.
- Gather the ends of the right and left trailer arms.
- Place the draw bar assembly between the trailer arms and align the holes, ensure the bend is upwards.
- Place one $2\frac{1}{2}$ " x $\frac{3}{8}$ " bolt through each hole, fit $\frac{3}{8}$ " Nyloc nut to each bolt and tighten securely.
- Test to ensure the trailer catch is correctly locking the trailer arms in the down position and the catch locking pin fits correctly when transporting the roller, for safety.

Step 6: Attaching wheels to trailer arms.

- Locate the two wheels for the left and right side trailer arms.

Assembly

- Check tires for the correct air pressure, approximately 18psi. Do not exceed this pressure. The tires act as the suspension, hence the low P.S.I.
- Remove wheel nuts from both hubs, slide wheels onto hub with air valves facing outwards. Replace wheel nuts and tighten securely.
- Ensure the taper on the nuts, mate into the wheel tapers correctly.

Step 7: Correct dampener strut operation

- When the roller is in the trailing position carefully hold the draw bar assembly, release the locking catch, gently with a firm grip begin to raise the draw bar, when it has travelled sufficiently the dampener strut will take over and prevent the trailer arms rapidly rotating on it's axle, allowing the roller to lower to the surface gently. This prevents the operator from being injured. When the roller is resting on the ground push the trailer arms back gently, **(do not use excessive force)** until the trailer arms will travel no further. The dampener strut is designed to hold the trailer arms back behind the operator with the wheels off the ground.

Step 8: Replace engine oil

- A tag is placed on the engine's On/Off switch indicating you must fill the machine with oil prior to operation. Low oil level will cause the engine to stop on steep hills, the engine cut off safety switch is designed this way to protect the engine from damage if low in oil.
- The oil in the engine upon delivery (if not pre-

delivered) is to prevent the inside of the engine from corroding, replace it with the correct engine oil, as per the manufacturers specifications.

Step 9: Transmission oil tank breather.

- Unscrew the plastic plug from the top of the tank if fitted and replace it with the anti-splash breather supplied. Seal damage and oil leakage will occur if the breather is not installed. If this is not done damage to the seals in the transmission will occur.

Step 10: Lubricate smoothing head pivot bearings.

- There is a grease nipple or zirk located on both smoothing head centre ball joint swivels. Apply grease to lubricate fittings.
- When rolling of the green is completed, move the roller onto the fringe, stop the engine, lock the trailer into the trailing position, connect it to the towing vehicle then move off to the next green to be rolled. Do not put the trailer down into the towing position on the green; damage may occur to the green from the roller tires and body. Remember turn off the fuel cock whilst towing the roller

Operation procedures

Operation procedures

Pre-operation checks

- Check engine as per Honda manual.
- Ensure steering joystick has no looseness.
- Check that foot pedal depresses under normal foot pressure in both directions and returns to the neutral position. (Similar resistance to a motor vehicle clutch). If this action is not smooth, check the yoke and transmission struts for correct operation.
- Ensure that the draw bar locking catch mechanism is securely locked to the main draw bar and the safety pin is fitted when trailing the roller.
- Check and tighten grub screws fitted to the end bearing lock rings on the rubber coated drive roller and the spiker shaft bearings & pivot bearings on each smoothing head.
- Grease lightly bearings fitted to drive roller, spiker shaft and Smoothing Head pivot bearings. Replace plastic caps if fitted.
- Grease rod ends, sparingly.
- Check tire pressure for proper operating pressure (18psi). **Do not over inflate.**
- Check for oil and fuel leaks - rectify before using machine.
- Lubricate the drive chain with a suitable chain lubricant.

Standard operation procedures

- Inspect and check that the roller is serviceable prior to departing from workshop.
- Use a suitable towing vehicle to move roller from green to green.
- Maximum recommended towing speed would be equal to a motorized golf buggy. Approximately 4mph/7kph. Towing at excess speed or across rough terrain may cause damage to the machine and trailer.
- When approaching the green do not tow the roller onto the green to set up, put the roller on the fringe of the green. Put trailer in the up position, start up the roller and drive it onto the green.
- Greens can be rolled in any direction; take care to ensure there are no crease lines produced on the surface.
- It is recommended that you place the smoothing head rollers on the high side of the green when rolling. This increases the weight on the rubber drive roller and gives better traction, it also reduces slipping or spinning of the drive roller on the green, depending also on the operators ability. Whilst becoming familiar with the roller, set the throttle at about $\frac{1}{2}$ - $\frac{3}{4}$ speed. Press the left or right foot pedal down gently but not suddenly. Be smooth with your action, hold in this position until nearing the edge of the green, then take your foot gently off the pedal, the roller will come to a stop. Rest your other foot on the opposite pedal and gently apply the pressure to the pedal. It then starts to move the roller in the opposite direction. Once again be gentle with the pedal, but not sudden. By using the left and right pedal in this manner, will ensure there is no damage to the green and less wear and tear on the equipment and operator.

Operation procedures

- The correct procedure for rolling the green is:
 - (a) Select the correct direction to roll the green, remember this roller can roll the greens in all directions.
 - (b) Start on one side of the green and work your way across the green in a zigzag fashion, slightly overlapping each lap you roll: this makes sure you miss no part of the green and all of the green is rolled. Avoid coming back across the green to roll missed areas if possible. You should be able to complete the rolling of 18 greens in the same time or quicker than by mowing using a triplex mower.
- When rolling of the green is completed, move the roller onto the fringe, stop the engine, lock the trailer into the trailing position, connect it to the towing vehicle then move off to the next green to be rolled. Do not put the trailer down into the towing position on the green; damage may occur to the green from the roller tires and body.
- Remember turn off the fuel cock whilst towing the roller.

Emergency and Park brake

- To engage, push parking lever forward until it will travel no further, the lever operates on a over cam principal, when it is fully engaged the lever will remain in this position with the brake applied. To dis-engage the park brake, pull the lever up and back. The lever will remain in the off position until re-applied. Do not operate the roller with the emergency brake engaged, damage to the drive roller rubber coating will occur.
- Ensure the park brake is released prior to operating the roller, if not irreparable damage to the rubber on the drive roller will occur.

Points to remember

- Make sure the roller is serviceable before rolling.
- Start rolling from the fringe of the green.
- Smooth operation on the foot pedals.
- Pick a point on the other side of the green to roll to.
- Do not look at the green close to the roller; it makes it difficult to steer the roller straight; look well ahead.
- Use 1/2 throttle until you are proficient at operating the roller.
- Once you choose your rolling line hold the joystick steady, correcting direction gently as required.
- Move the steering joystick a little at a time to change direction; excessive movement of the joystick makes it difficult to maintain a straight line.
- Roll in straight lines.
- Do not leave the engine running with the roller parked on the green; the engine vibration will cause roller depression marks on the green.
- Move off the green when rolling is complete before putting the trailer in the down position.
- When rolling steep greens and the engine stops, check engine oil level. The engine is fitted with a safety switch; when the engine oil level is low the engine will stop.

Maintenance

Maintenance

- Stop engine before performing any maintenance.
- Service the Honda engine according to the manufacturer's maintenance schedule.

Transmission (pump, Eaton 11)

- Initially, change the oil at 50 hours running time, then;
- Change oil every 500 hours or annually, whichever occurs first.
- Change hydraulic oil filter every 500 hours or annually, whichever occurs first.
- Only use the manufacturer's recommended replacement oil filter .
- When fitting the filter, follow the instructions supplied with the filter. This will ensure that the filter remains tight and that no leaks occur.
- Check all hard line oil pipes for rubbing, excessive vibration, leaks and tightness on a regular basis.
- Check transmission oil level on oil tank sight glass. Oil level should remain at a minimum of 25mm (1") and at a maximum of 40mm (1.5") from the top of the tank.
- Oil Capacity including filter is 6 liters or 5.3 U.S. quarts. For the ultimate performance we use and recommend the Penrite synthetic 5 SAE 5W-60 transmission oil. (Part No. R5226)

Storing

- It is important to store this roller in the towing position. This ensures the trailer strut is in the closed position, protecting the shaft from corrosion, then failure and also the weight is taken off the roller bearings.

Service of the drive chain system

- Replacement - Some chains look a like, but they are not, use only the chain and sprockets recommended as per the correct spare parts number. Wrong pitch drive chain fitted will cause excessive sprocket wear and possible drive failure.
- Tensioning the drive chain - No adjustment is required; the chain tension is automatically adjusted.

Lubrication

- Lubricate Drive Chain with Chain Oil, WD40 or equivalent (CRC; Penetrene etc.) each time prior to rolling of the Greens.

Service of smoothing roller bearings

- Whilst the Roller is suspended by the Trailer, check operational smoothness of the bearings fitted to each smoothing roller by rotating the rollers by hand. If bearing tightness, roughness or excessive looseness is detected, replace the faulty bearings, or rollers.

Maintenance

- If bearings are faulty
 - (a) Remove the complete smoothing head from the machine, undo the four swivel mount bolts on upper body and steering rod, wheel the roller away until the total head is exposed to work on.
 - (b) Remove roller shaft bolts from end plates, remove rollers from the heads.
 - (c) Screw a bolt back into the shaft end, knock out one end bearing, then use the same shaft to knock out the other end bearing. Some rollers are fully sealed and cannot be serviced.
 - (d) Fit new bearings, replace rollers into the heads, lubricate shaft bolts with an anti seize compound before installing them. Tighten securely and ensure rollers rotate freely when fully tightened.
 - (e) Be sure the spacing washers are fitted to the shaft ends before installing the rollers into the heads, in the correct sequence smaller diameter washer first and the larger diameter washer last.
 - (f) Sometimes, if the rollers do not rotate freely when installed use a soft headed hammer to hit the securing bolts on each end of the head, this will seat all parts and allow the roller to rotate freely.
 - (g) If the rods are removed or lengths altered ensure they are correctly adjusted so that the three heads are parallel to each other when in the straight ahead position. Adjust if necessary.

Changing engine oil

- Change oil and service as per the manufacturers Servicing Schedule enclosed as a separate insert to this manual.

Changing transmission oil

- See page 12 and 14.

Lubricating transmission yoke slides

- Lubricate slide where transmission strut attaches to the yoke, use a general purpose grease. If this is not done sticking of components in this area may occur, this will cause roller spin on the takeoff or foot pedal jamming. If fitted with nylon washers this is not necessary.

Ongoing Maintenance, Lubricant and Replacement Schedule (below)

Note. Areas indicated with a * need to be changed when defective or as required. This may be before the recommended replacement schedule. Please replace all parts as necessary.

Description	Pre-Delivery	Pre-Operating	12 Monthly
Check Engine oil	✓	✓	
Check Transmission Oil Level	✓	✓	
Beware of contaminants entering the transmission	✓	✓	
Lubricate drive chain with WD40 or equivalent	✓	✓	
Check Tires Max 18 P.S.I.	✓	✓	
Check Gas	✓	✓	
Check Smoothing Roller Bearing	✓	✓	
Check Drive Roller Bearings	✓	✓	
Check for loose Nuts and Bolts	✓	✓	
Renew Engine Oil	as per manufacturers Handbook		
Renew Transmission Oil - See page 1 for correct oil	every 500hrs or...		✓
Renew Transmission Oil Filter	*		✓
Renew Smoothing Roller Bearings	*		✓
Renew Drive Roller Bearings	*		✓
Renew Chain Tensioner Sprocket Bearings	*		✓
Renew Drive Chain	*		✓
Replace Foot Pedal Struts	*		
Replace Trailer Strut	*		

Fault Finding

Fault Finding

Roller will not move one or either way, check

- Chain is okay.
- Sprockets are not worn or slipping on the shaft.
- Foot control is operating - check all arms are secure.
- For Sheared Sprocket Keys.

Roller will not steer, check

- Woodruff Key is in place and not sheared.
- Rod ends are connected to smoothing roller head and the steering arm.
- Centre swivel bearing on top centre of each smoothing roller head has not seized.
- Connecting rod are in place and serviceable.
- Roller shaft bolts in the head centre have not worked loose and are locking.

Roller has excessive vibration, check

- Ensure the engine shaft is correctly aligned with the transmission shaft and or remove shims if too high or low - Align left or right.
- Disconnect engine-to-transmission and isolate the drive chain to determine whether the problem is in the engine or in the transmissions.
- If engine is at fault contact your nearest engine agent for rectification.

- If the transmission is at fault, repair or replace as necessary, or seek professional advice from a local Eaton Service Center.

Smoothing rollers seized, check

- Bearings have not seized.

Rubber drive roller will not rotate, check

- Roller shaft end bearings have not seized.
- Broken chain.
- Slipping sprockets.
- The Park Brake is not locked on.
- Accumulated dry debris is not locking the smoothing rollers.

Operating Positions

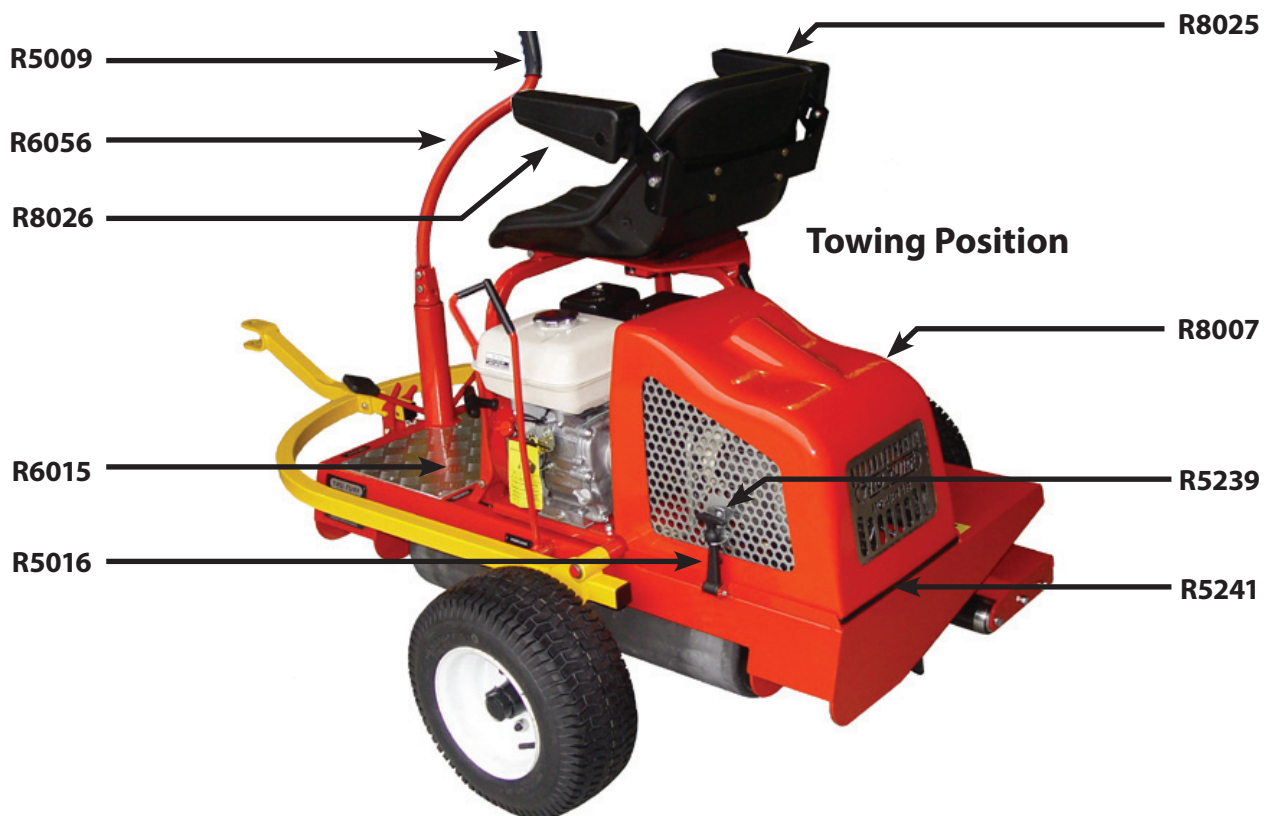

Bottom view, foot pedal & top view

THE 1/2" SIZE FOR THE STEER & SMOOTHING HEAD CONNECTING RODS AND STEER ARM APPLIES FROM SERIAL NUMBER R10923 TO R11557 INCLUSIVE

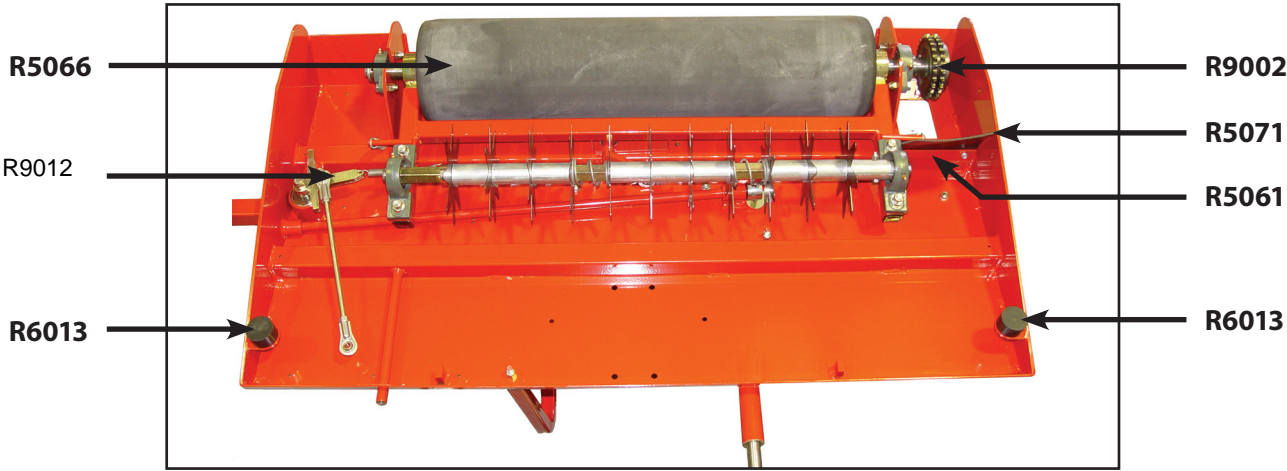

Bottom View

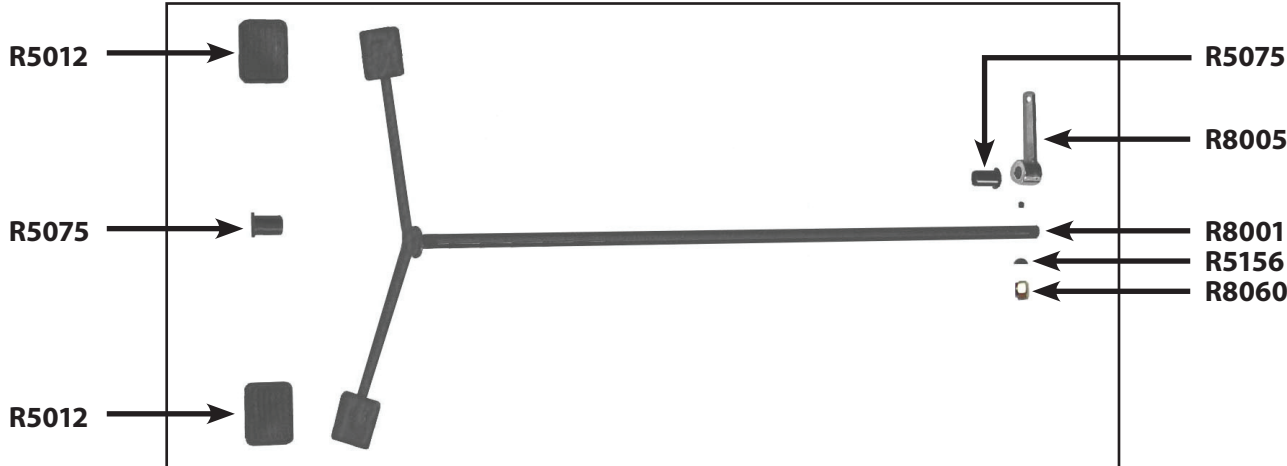

Foot Control

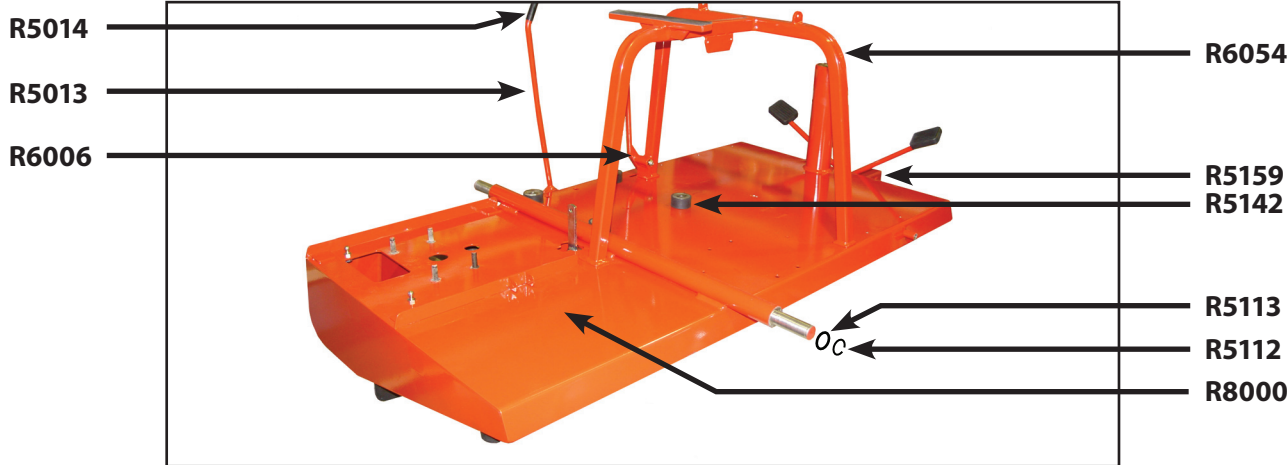

Top View

Engine

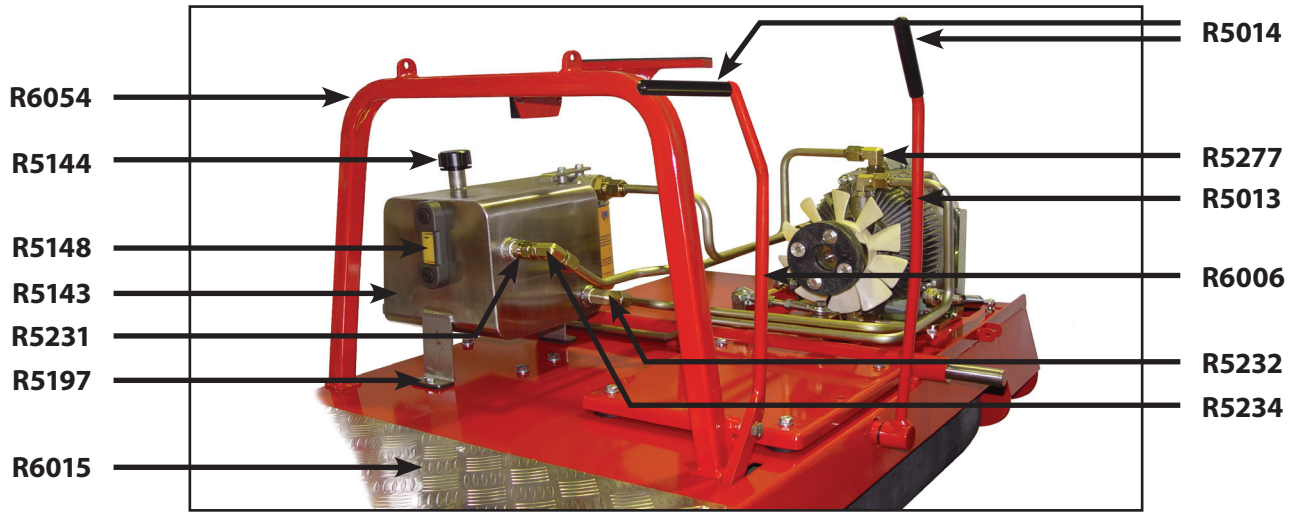

Top View

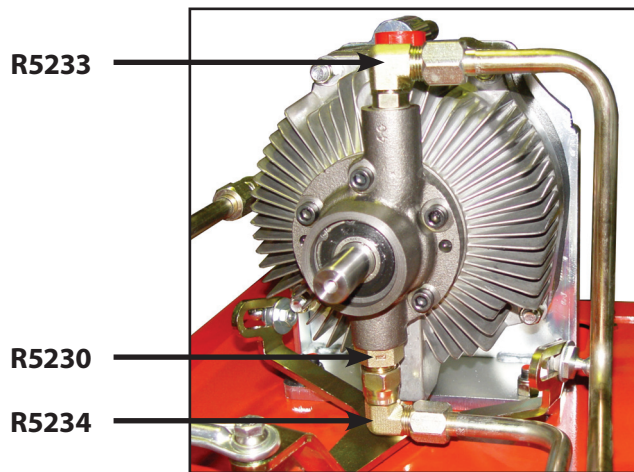

Oil Line Fittings

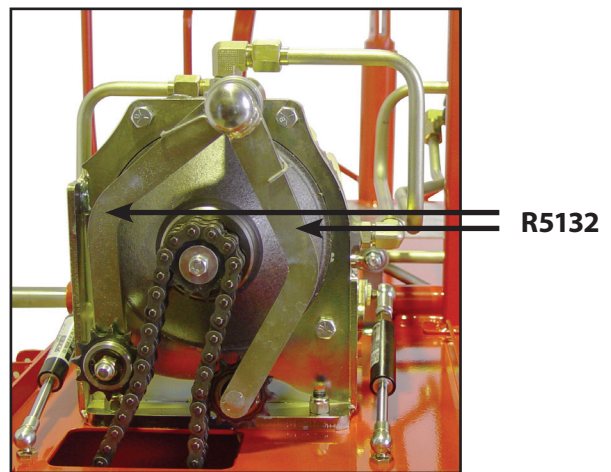

Chain Tensioner

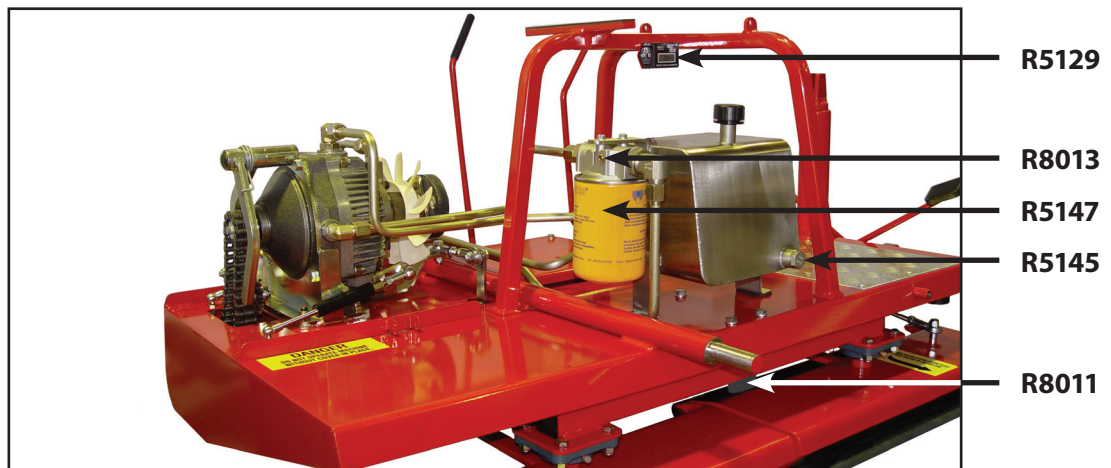

Top Rear View

Oil lines

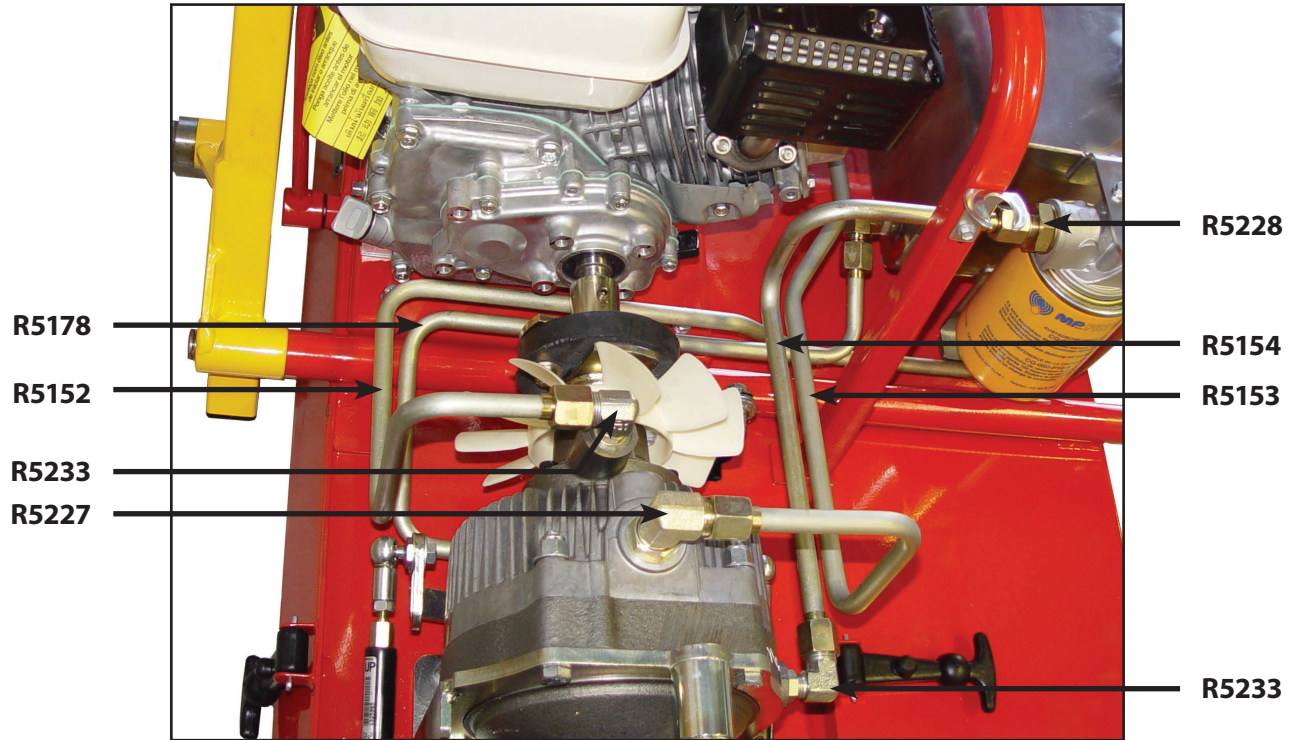

Oil Lines

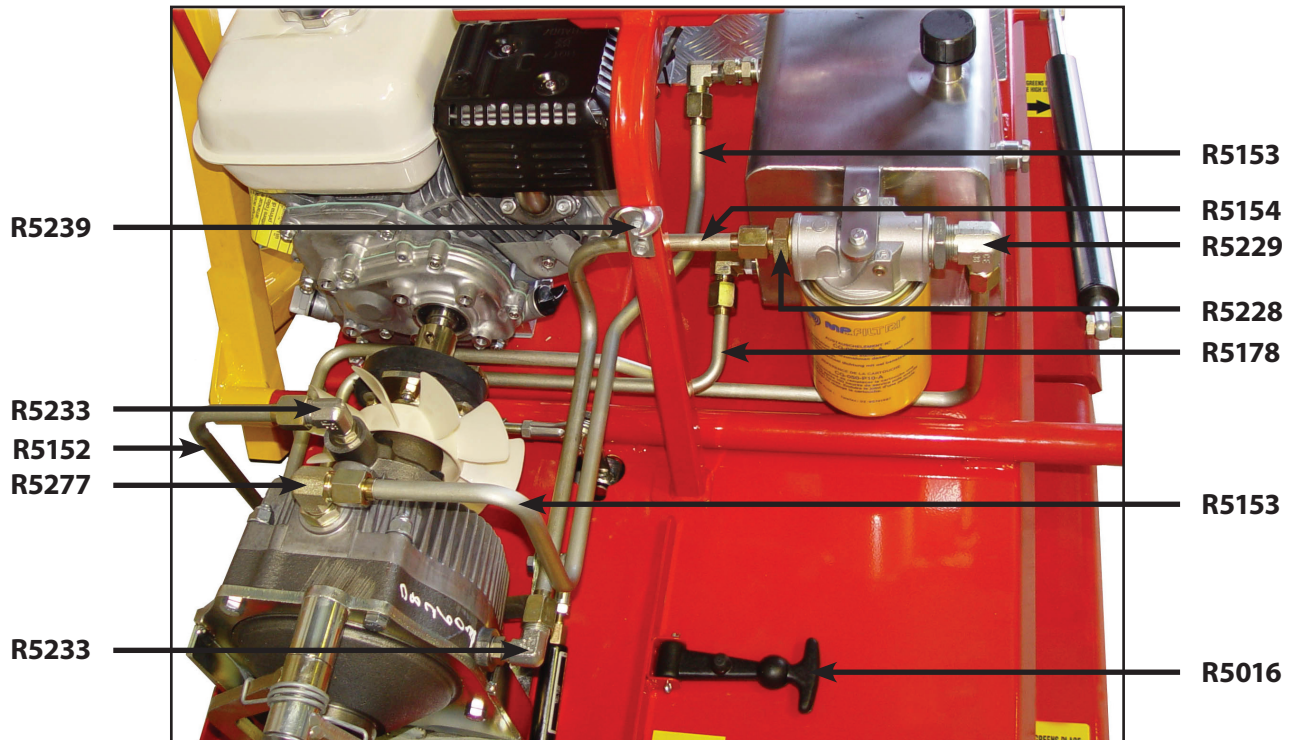

Oil Lines

Transmission & yoke

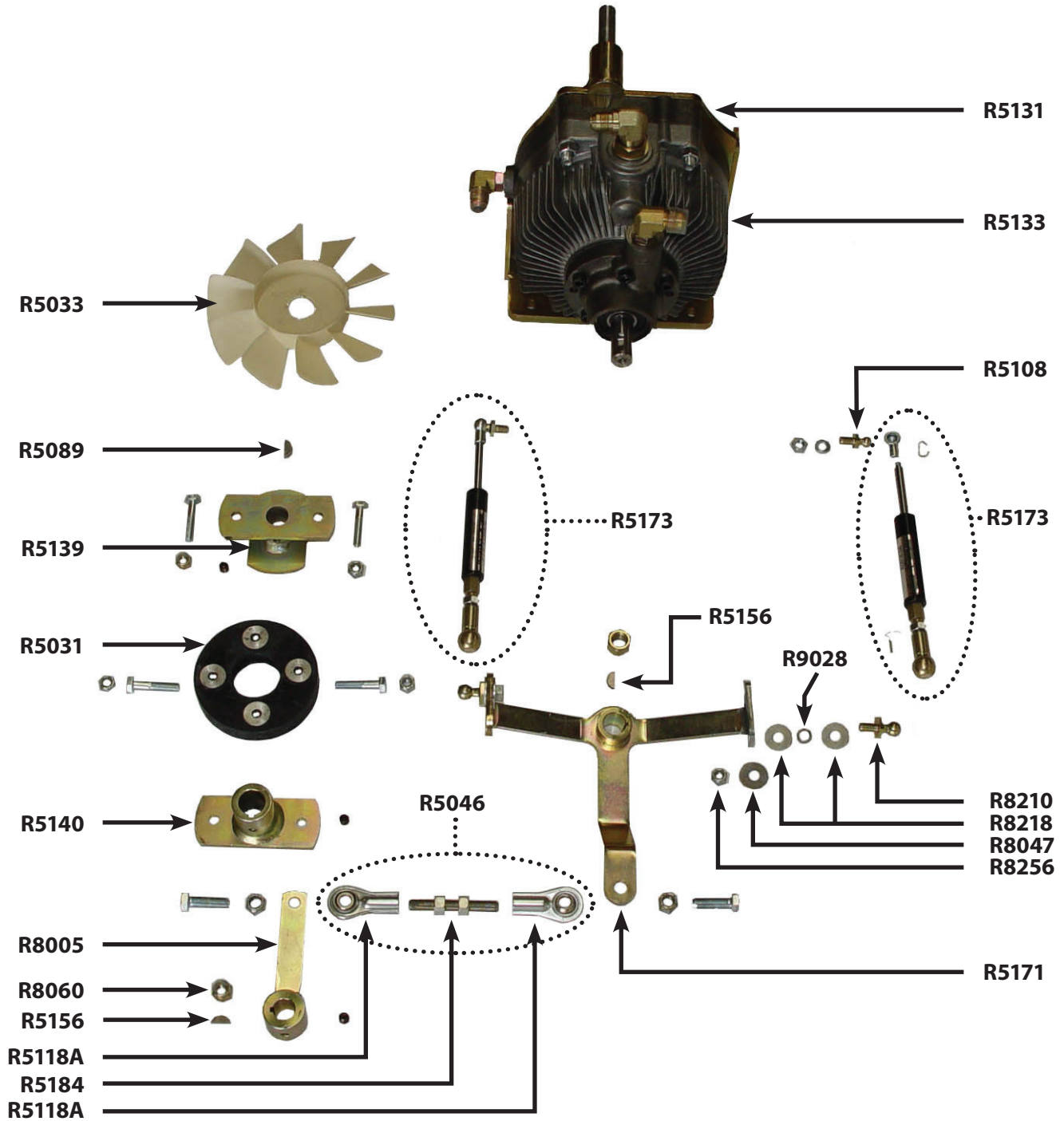

Transmission & chain tensioner

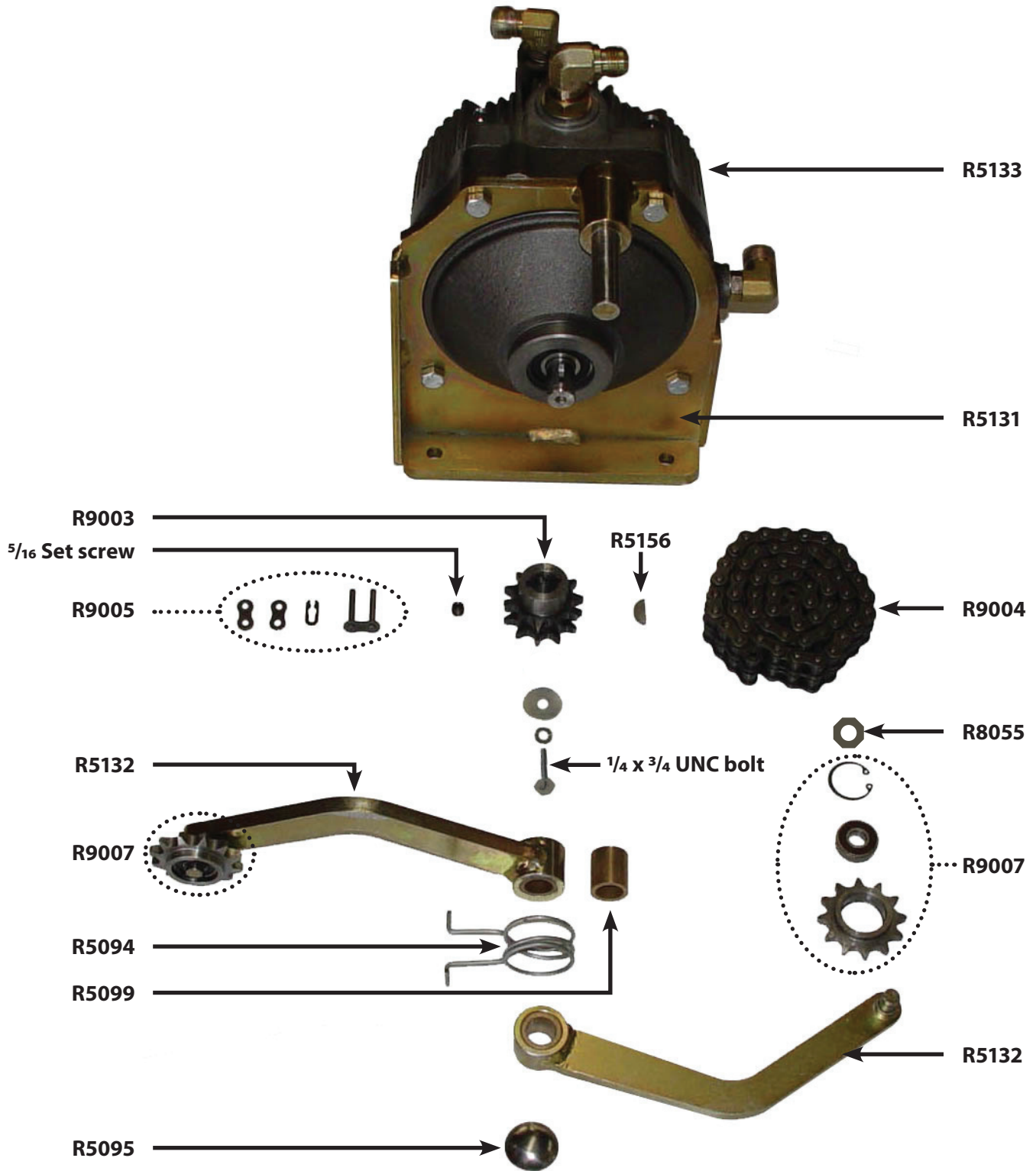

Drive roller & spiker

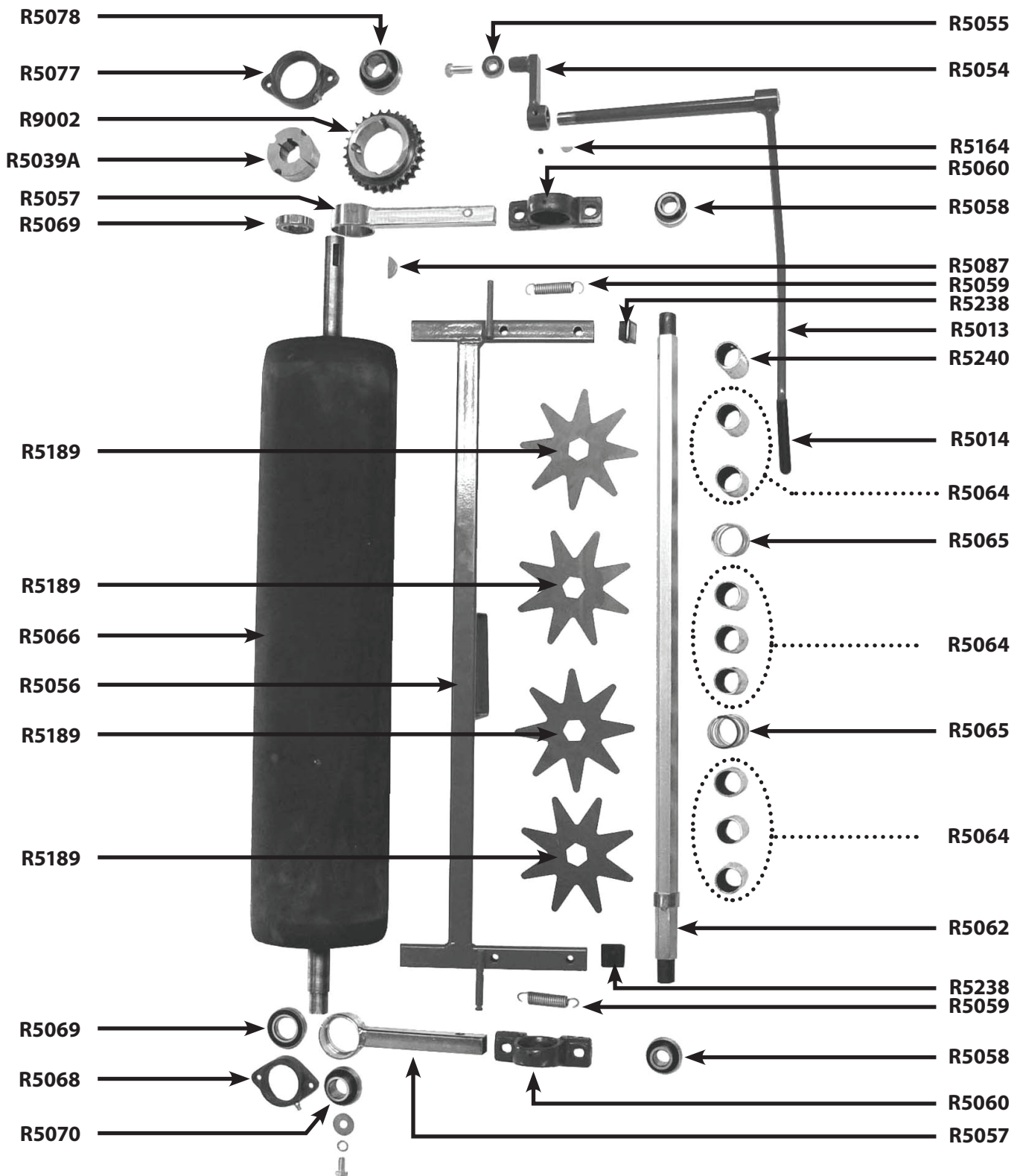

Pivot frame & smoothing heads

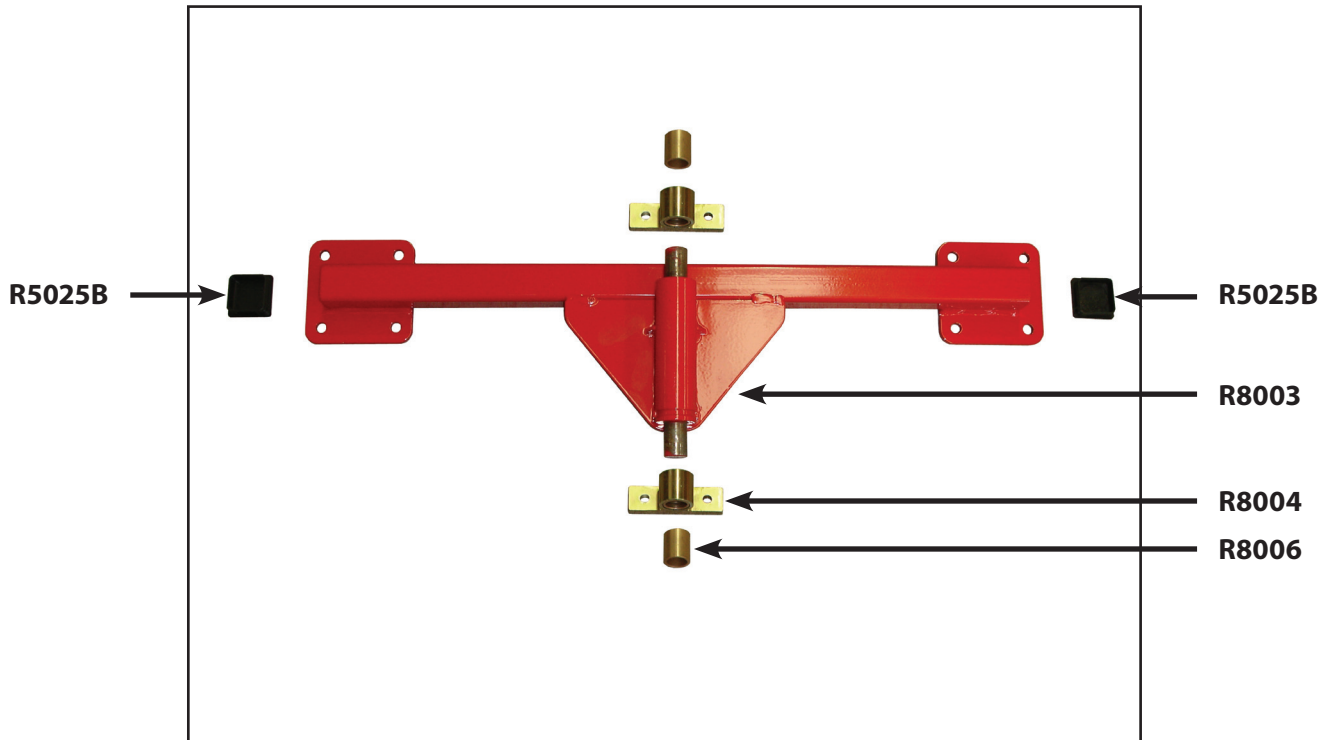

Pivot arm

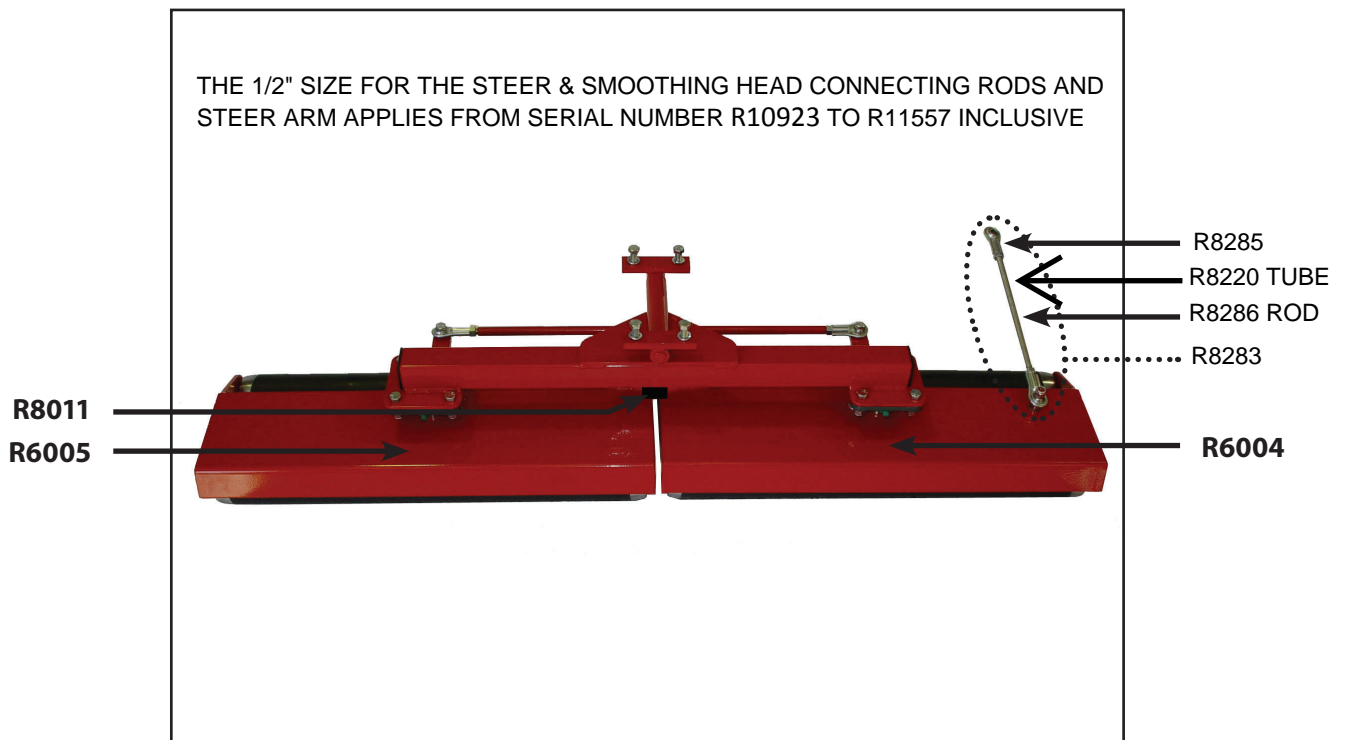

Pivot arm & smoothing head

Smoothing head & components

THE 1/2" SIZE FOR THE STEER & SMOOTHING HEAD CONNECTING RODS AND STEER ARM APPLIES FROM SERIAL NUMBER R10923 TO R11557 INCLUSIVE

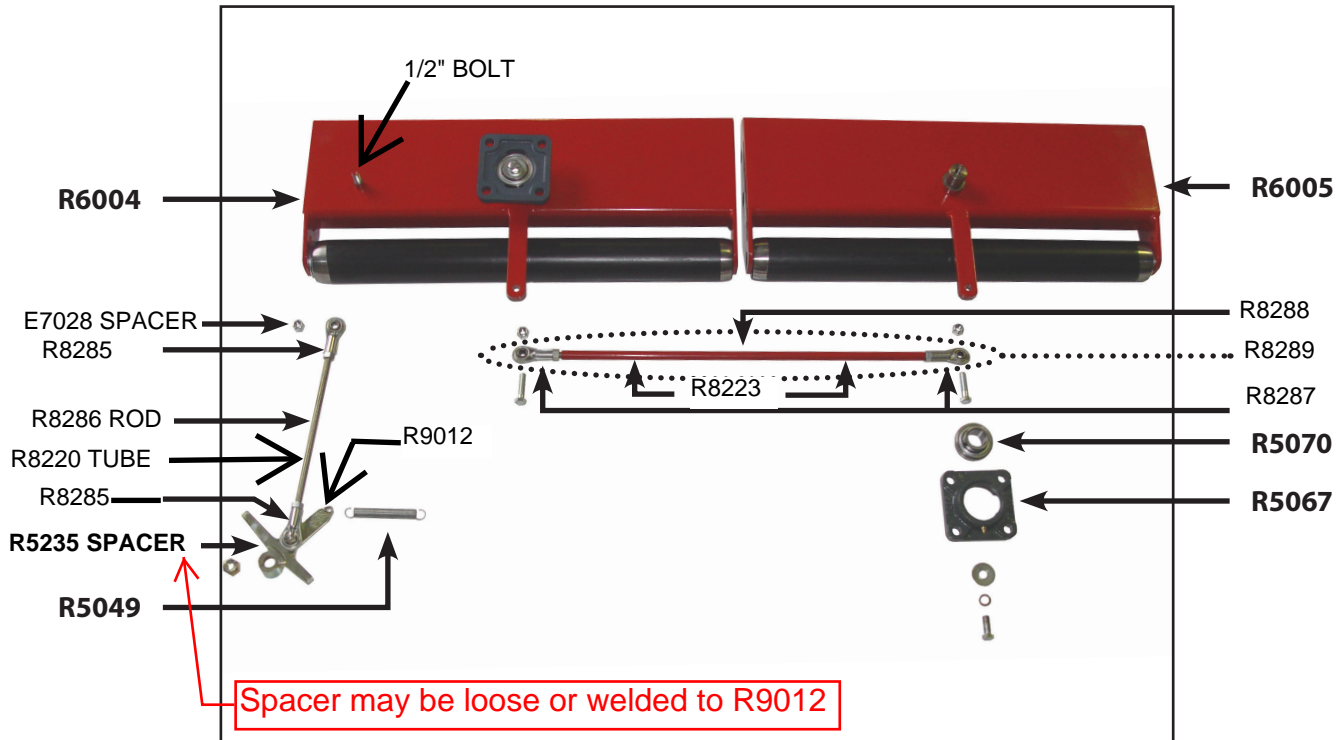

Smoothing head

A NEW DESIGN SMOOTHING ROLLER R8217 IS AVAILABLE TO REPLACE BOTH R8021 & R8290 TYPES.

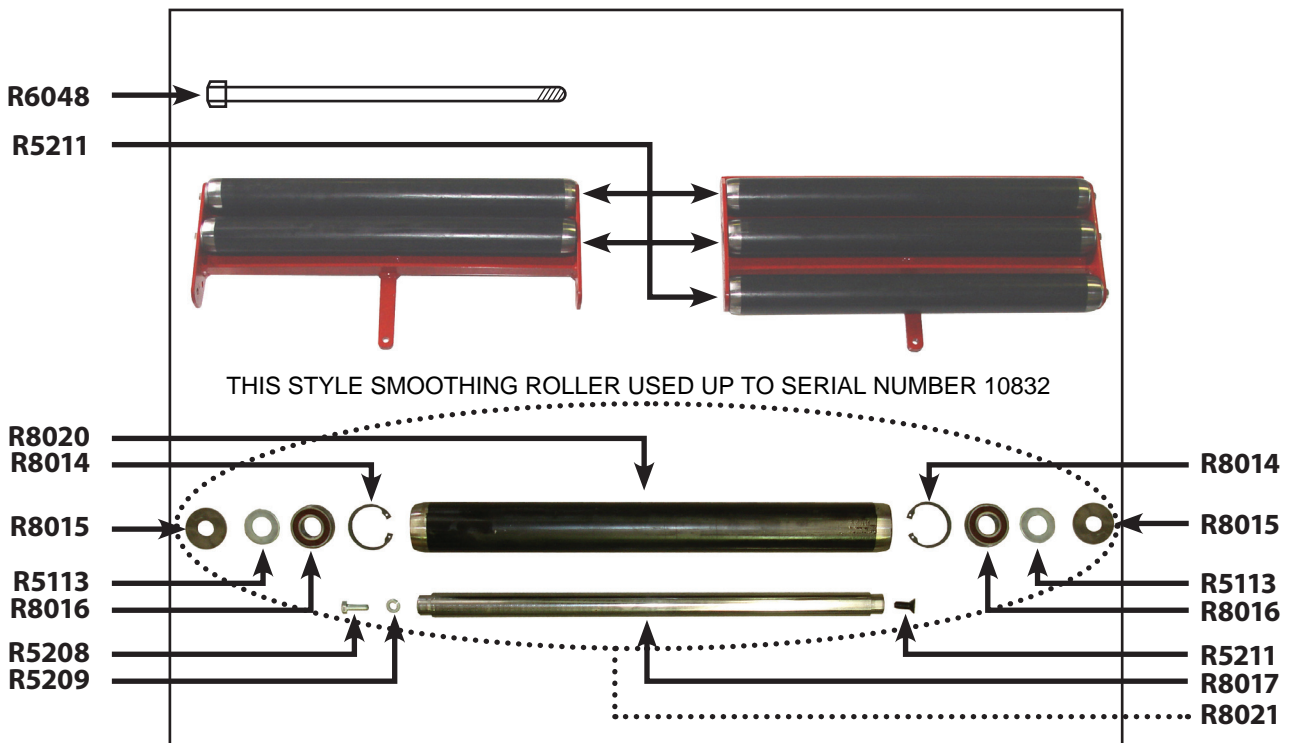

Smoothing head & components

R5208
R5209

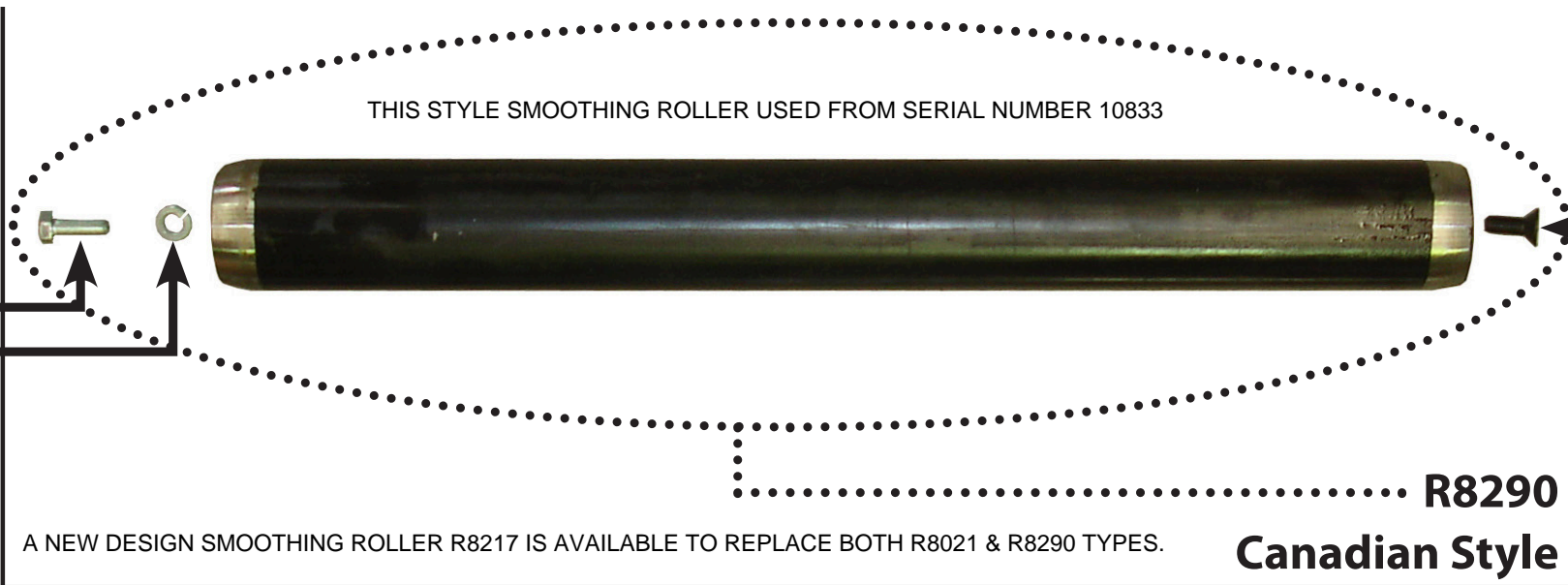

R5211

R8290

Canadian Style

Engine with base & seat with base

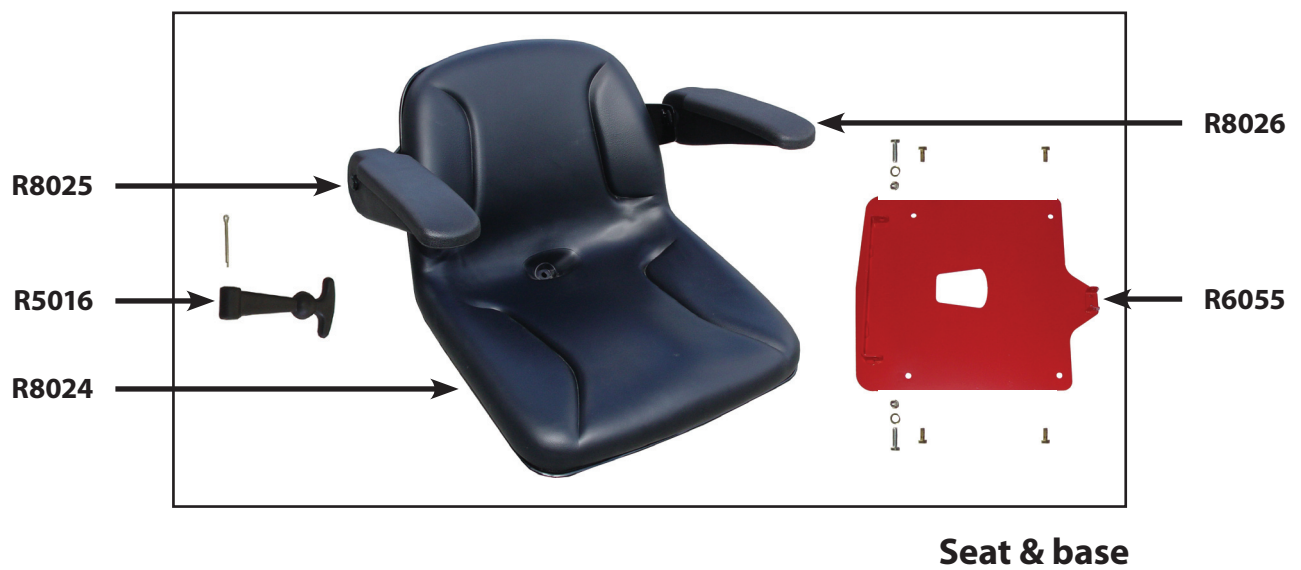
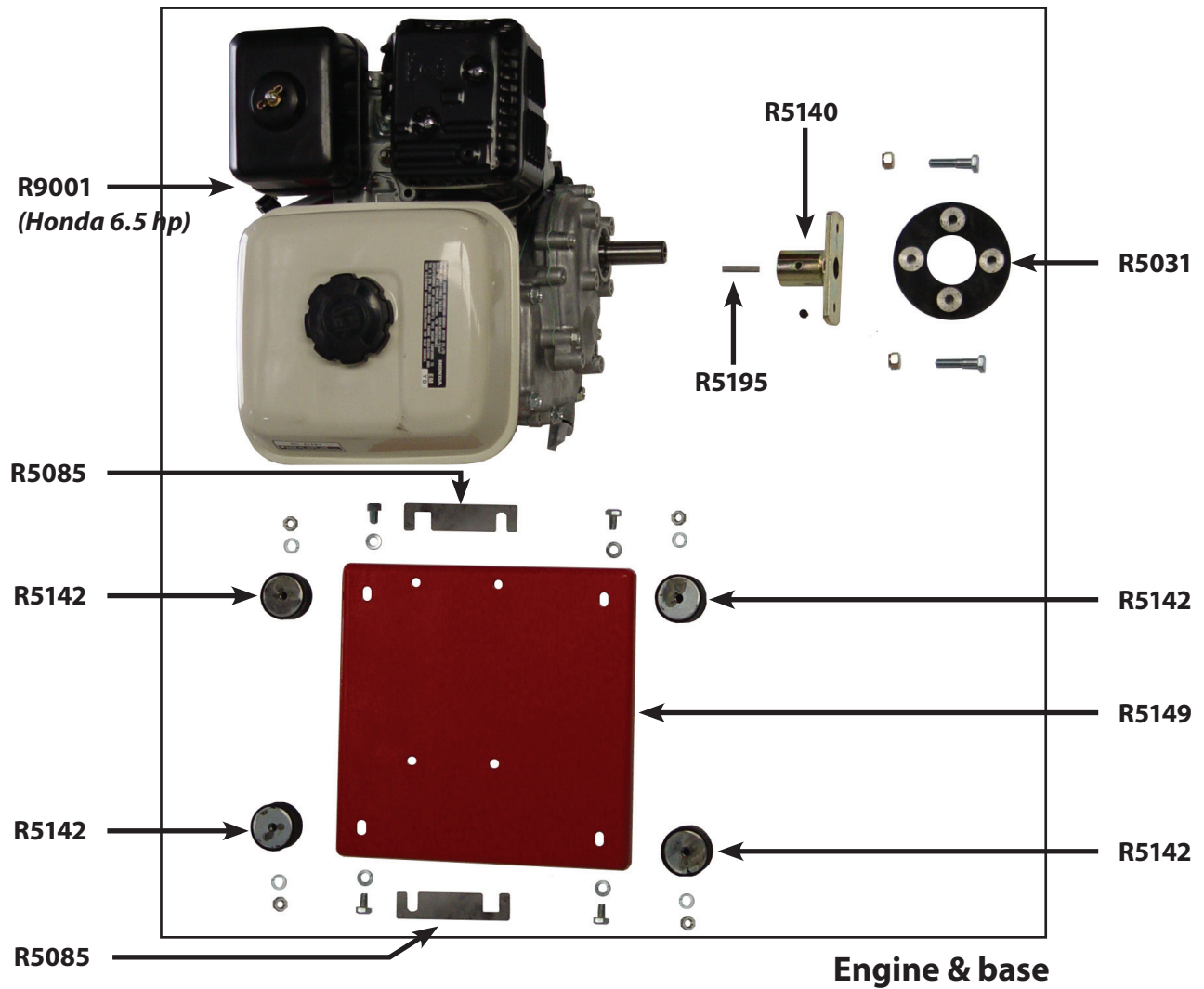

Drawbar, brake & joystick

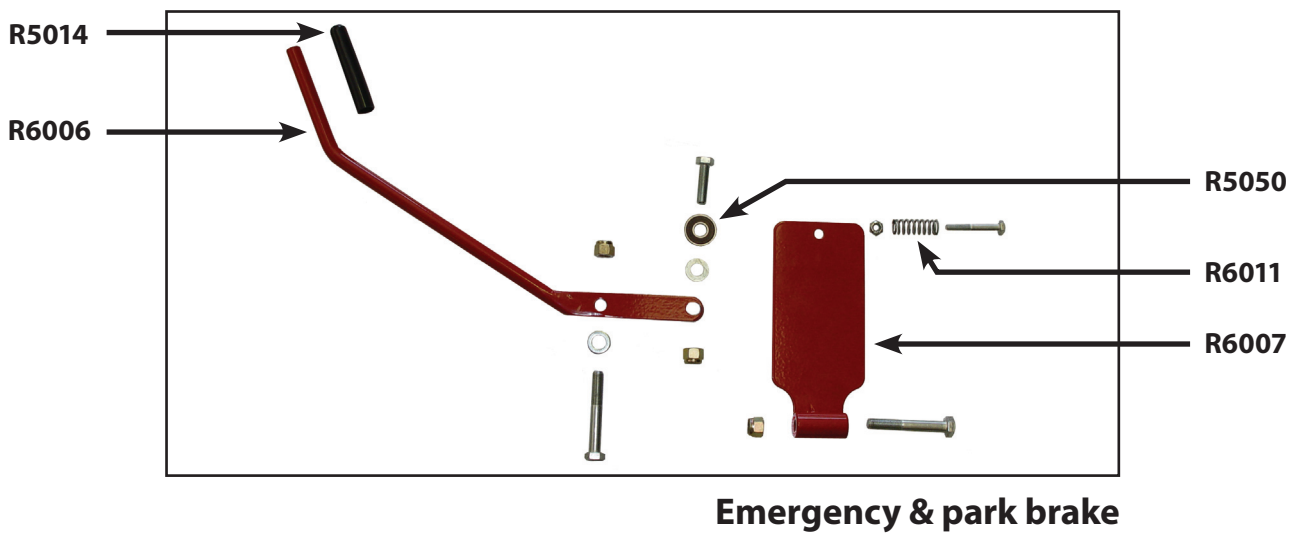
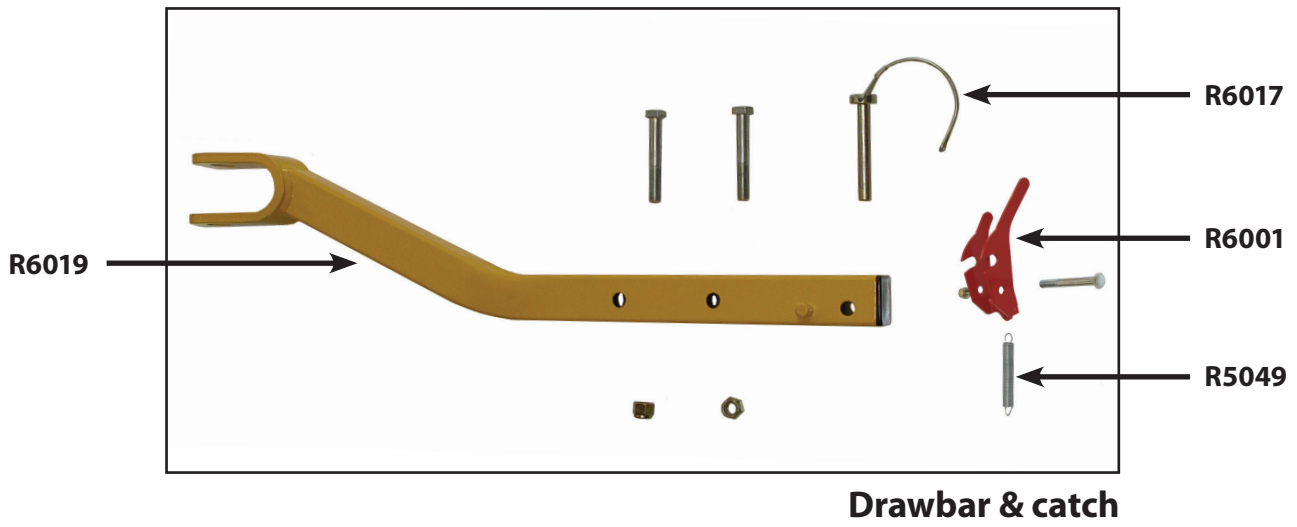

THE 1/2" SIZE FOR THE STEERING ARM BOLT, STEER & SMOOTHING HEAD CONNECTING RODS APPLIES FROM SERIAL NUMBER R10923 ONWARDS

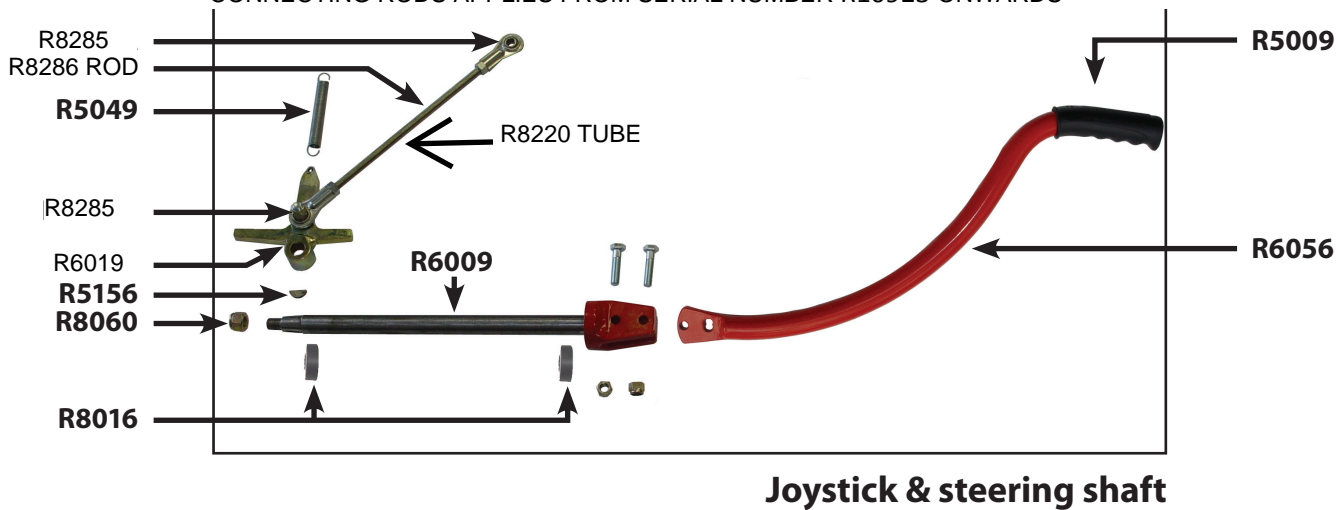

Trailer frame & components

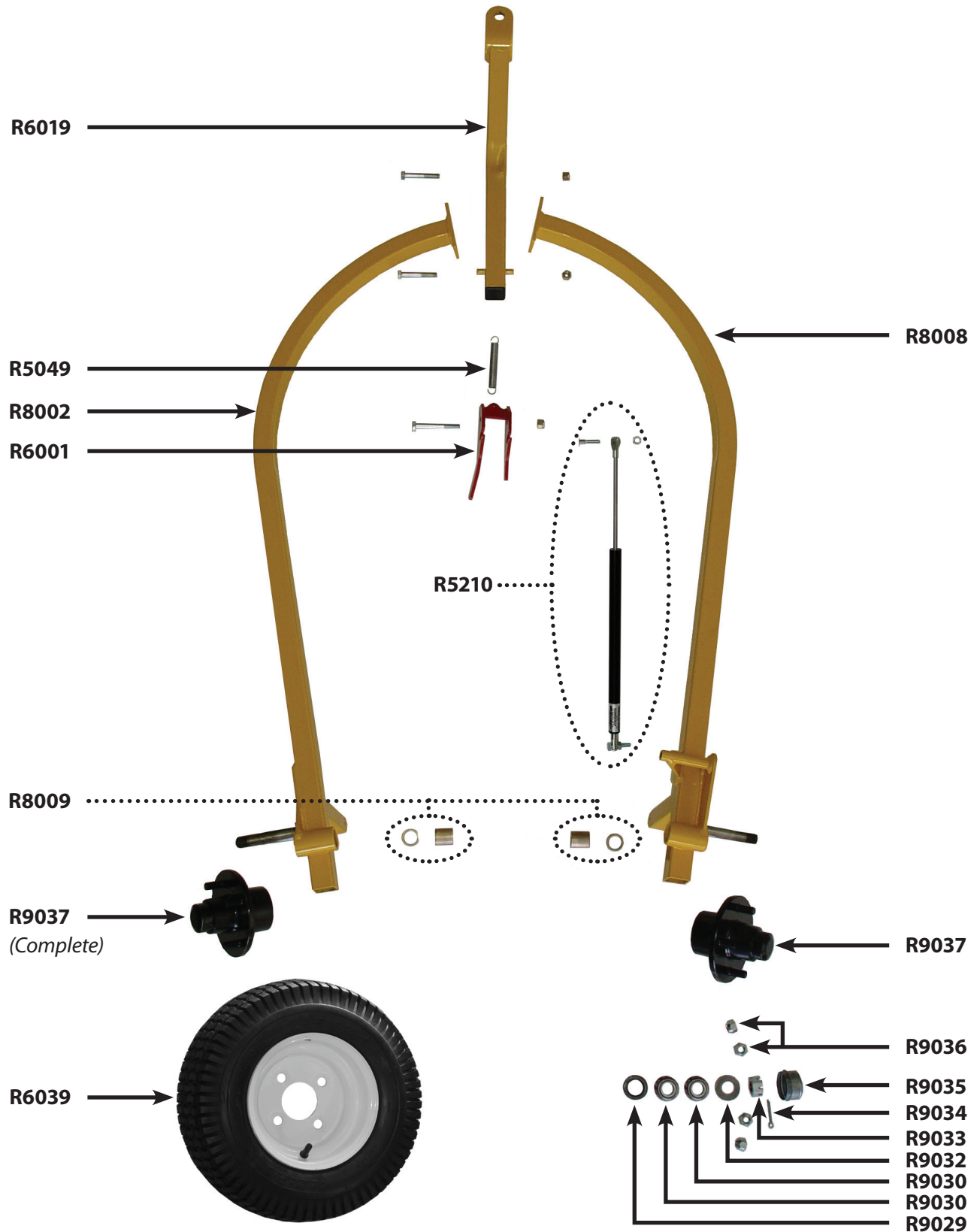

Options

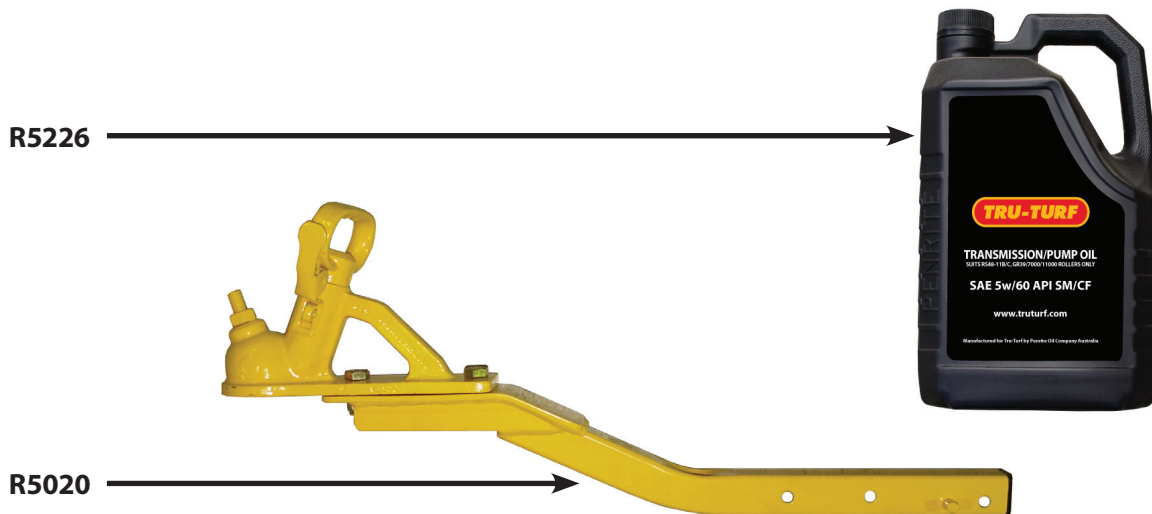
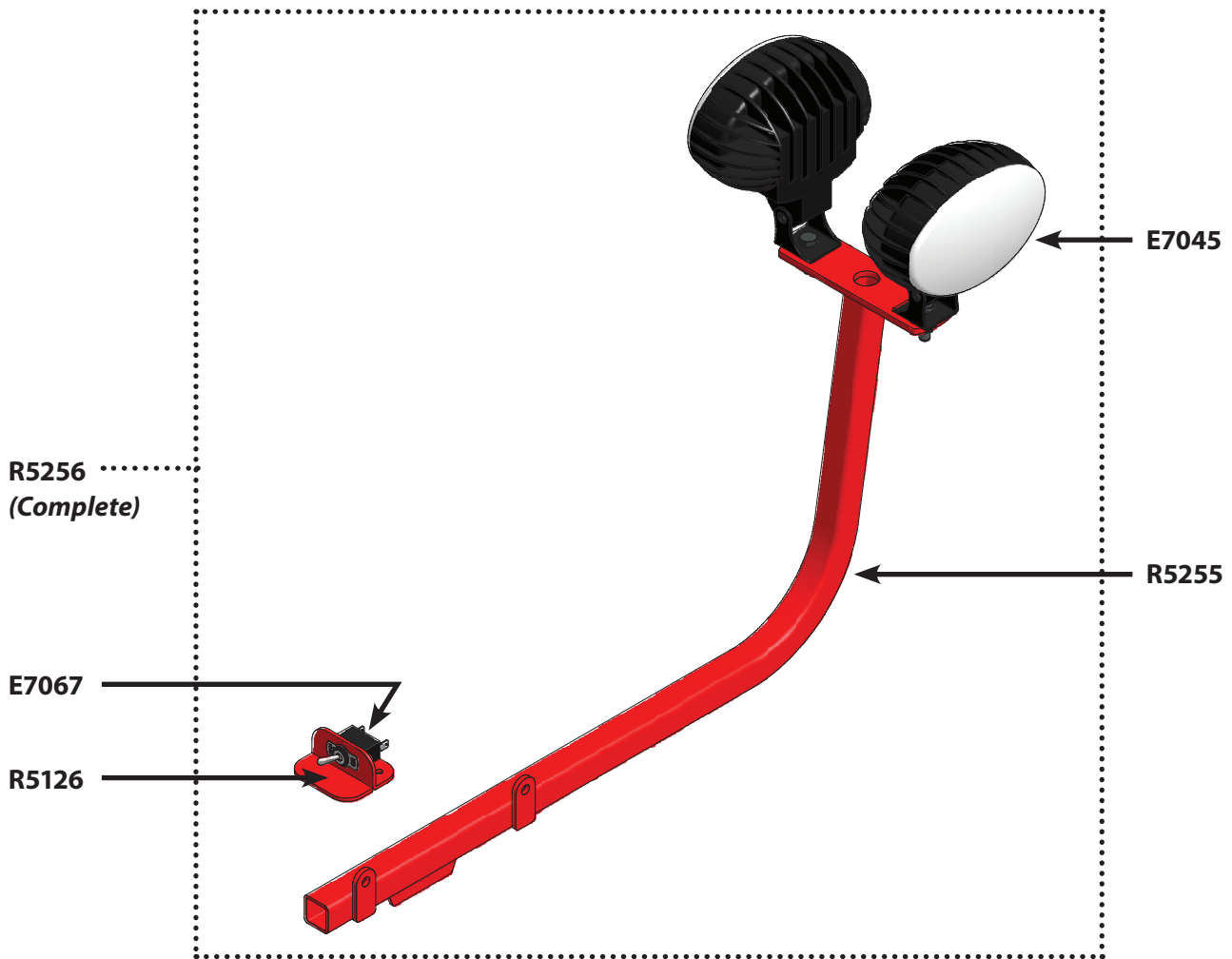

Labels



← R8010



Parts List

Part No.	Description	Page
R5009	Grip; Hand; Joystick	13, 23
R5012	Pad; Rubber; Foot Pedal	14
R5013	Lever; Spiker Handle	14, 15
R5014	Grip; Lever; Spiker Handle	14, 15, 19, 23
R5016	Rubber; Cover; Transmission & Seat	13, 16, 22
R5025B	Plug, Square	20
R5031	Coupling; Rubber	17, 22
R5033	Fan	17
R5039A	Bush; Taper Lock	19
R5046	Rod Unit; Connecting Arm; Foot Pedal to Yoke	17
R5049	Spring; Steering Return	21, 23, 24
R5054	Arm; Spiker Engaging	19
R5055	Bearing; 6201; Arm; Spiker Engaging	19
R5056	Frame; "H" Spiker	19
R5057	Arm; Bearing Carrier; Spiker Frame	19
R5058	Bearing; B4	19
R5059	Spring; Return; Spiker Frame	19
R5060	Housing; P204; for B4	19
R5061	Strap; Mud Flap	14
R5062	Shaft; Hexagon; Spiker	19
R5064	Spacer; Set; Spiker Shaft	19
R5065	Spring; Spiker Spacer; fits on Hex Shaft	19
R5066	Roller; Drive	14, 19
R5067	Housing; F205; 4 hole; for R5070 Bearing	21
R5068	Housing; LFL5J; 2 hole for R5070 Bearing	19
R5069	Bearing; 6006; Fits R5057	19
R5070	Bearing; B5	19, 21
R5071	Mud Flap	14
R5073	Rod Unit; Steering Arm to Smoothing Head	20
R5075	Bush; Nylon; Black	14
R5077	Housing; LFL6J; for R5078 B6 Bearings	19
R5078	Bearing; B6	19
R5084	Rod Unit; Connecting Smoothing Heads, complete	21
R5085	Shim; Honda; 1.0 mm Thick	22
R5087	Key, Woodruff 8x30	19
R5089	Key; Woodruff 3/16"	17
R5094	Spring; Arm; Chain Tensioner	18
R5095	Washer; Capped	18
R5099	Bush; Bronze; for Chain Tensioner Arms	18
R5108	Ball Fitting; Small Flange	17
R5112	Circlip; External 25mm	14
R5113	Washer, Flat, 24x44x2 mm	14, 21

R5118A	Rod End	17, 20, 21, 23
R5129	Meter; Hour/Tach	15
R5131	Bracket; Transmission; Eaton 11	17, 18
R5132	Arm; Chain Tensioner	15, 18
R5133	Transmission; Eaton 11	17, 18
R5139	Coupling; Transmission; Eaton 11 Honda 6.5hp	17
R5140	Coupling; Engine; Honda 6.5hp	17, 22
R5142	Cushion; Rubber; for Engine Base Plate	14, 22
R5143	Tank; Stainless Steel; Transmission Oil	15
R5144	Breather; Tank; Transmission Oil	15
R5145	Plug; Drain; Tank; Transmission Oil	15
R5147	Cartridge; Filter; Tank; Transmission Oil	15
R5148	Gauge; Sight; Tank; Transmission Oil	15
R5149	Plate; Mounting; Engine	22
R5152	Pipe; Oil	16
R5153	Pipe; Oil	16
R5154	Pipe; Oil	16
R5156	Key; Woodruff; 1/8" x 5/8"	14, 17, 18, 23
R5159	Rubber Strip; Rest; Trailer	14
R5164	Key; Woodruff; 4 x 6.5mm	19
R5171	Yoke; Eaton 11 Transmission	17
R5173	Strut; connects to R5171 Yoke	17
R5178	Pipe; Oil	16
R5184	Rod; Connects Transmission Yoke – Foot Pedal Arm	17
R5185	Rod; Connects Steering Arm to Smoothing Head	20, 21, 23
R5187	Tube 12.7mm x 495mm; For R5084 Rod	21
R5189	Spiker Blades, 8 point	19
R5194	Rod 3/8" x 570mm; Connects L & R Smoothing Heads	21
R5195	Key Honda 32.5 x 5 x 5mm	22
R5197	Pad; Rubber Oil Tank	15
R5208	Bolt, 3/8" x 1" NF	21
R5209	Spring Washer 3/8"	21
R5210	Kit; Strut; 32mm dia. Body complete	24
R5211	CSK Screw 3/8" x 1"	21
R5226	Oil; Transmission; 6Lt Containers	25
R5227	Fitting; 90 deg Elbow; M-10 ORB to M-8 JIC	16
R5228	Fitting; Straight M-12 BSPP-ORR to M-8 JIC with Dowty Seal	16
R5229	Fitting; 90 deg Elbow M-12 BSPP-ORR to M-8 JIC with Dowty Seal	16
R5230	Fitting; Straight M-10 ORB to M-8 JIC (S90-1214); Transmission	15
R5231	Fitting; Straight M 1/2" NPT to M-8 JIC (A-G-0812)	15
R5232	Fitting; 90 deg Elbow M-8 JIC to M 1/2" NPT (A-G-90-0812)	15
R5233	Fitting; 90 deg Elbow M-6 ORB to M-8 JIC (G-NP-90-1209)	15, 16
R5234	Fitting; 90 deg Elbow F-8 JIC SWIVEL to M-8 JIC (G-J-90-1212)	15

Parts List

R5235	Tube; Spacer; Steering Head	21
R5236	Plug; Plastic 1"x1"	19
R5238	Plug; Plastic 1 1/4" x 1 1/4"; Trailer	19, 20
R5239	Catch; Steel; Transmission/Seat	13, 16
R5240	Tube; Spiker Shaft; Locking Collar	19
R5241	Black; Mini Pinch weld	13
R6001	Catch; Trailer	23, 24
R6004	Smoothing Head; Front	20, 21
R6005	Smoothing Head; Rear	20, 21
R6006	Lever; Emergency & Park Brake	14, 15, 23
R6007	Plate; Brake	23
R6009	Shaft; Steering	23
R6011	Spring; Compression Brake	23
R6012	Arm; Steering	14, 23
R6013	Stop; Rubber, Smoothing Head	14
R6015	Plate, Footrest, Checker	13, 15
R6017	Pin; Safety, Drawbar	23
R6019	Drawbar	13, 23, 24
R6022	Plate; Spiker Lever	26
R6023	Plate; Emergency & Park Brake	26
R6024	Plate; Move Right	26
R6025	Plate; Move Left	26
R6039	Wheel / Tire 4 Stud	24
R6040	Sticker; Sloping Greens	26
R6041	Sticker; Danger, Cover Removal	26
R6048	Scraper; Rod	21
R6054	Seat; Frame	13, 14, 15
R6055	Plate; Seat Base; Michigan Seat	13, 22
R6056	Joystick	13, 23
R6057	Sticker; Tru-Turf	26
R6058	Sticker; Tire Pressure	26
R6059	Sticker; PGA	26
R8000	RS48-11C Body	14
R8001	Foot Pedals Tapered	14
R8002	Trailer Arm LH	24
R8003	Smoothing Head Pivot Frame	20
R8004	Smoothing Head Pivot Bush Holder	20
R8005	Foot Pedal Arm Tapered	14, 17
R8006	Bush Bronze Smoothing Head Pivot 20x26x30	20
R8007	RS48-11C Transmission Cover	13
R8008	Trailer Arm RH	24
R8009	Bush Bronze Trailer Arms 25x32x30	24
R8010	Naming Plate RS48-11C	26

R8011	Rubber Buffer, Pivot Frame	13, 15, 20
R8013	Housing; Filter; Tank; Transmission Oil	15
R8014	Circlip; Smoothing Rollers	21
R8015	Washer; Smoothing Roller 25X52X3	21
R8016	Bearing; 6205 Stainless Steel	21, 23
R8017	Shaft; Smoothing Roller Suites Tube R8020	21
R8020	Tube; Smoothing Roller with Circlip R8014	21
R8021	Tube; Complete Kit	21
R8024	Seat; Michigan	13, 22
R8025	Armrest RH	13, 22
R8026	Armrest LH	13, 22
R8047	5/16" Washer	17
R8055	Nyloc Nut 3/8"	18
R8060	Nut Nyloc, 1/2" UNC	14, 17, 23
R8210	Ball Fitting; Large Flange	17
R8218	Washer Nylon	17
R8256	Nyloc Nut M8	17
R9001	Engine Honda 6.5HP; with Flywheel & Lighting Coil	22
R9002	Sprocket; 27 tooth; Duplex; Drive Roller; Eaton 11 Trans. ANSI	14, 19
R9003	Sprocket; 11 Tooth; Duplex; ANSI	18
R9004	Chain, Duplex; Eaton 11 Transmission; ANSI	18
R9005	Joiner; Chain; Duplex Eaton 11 Transmission; ANSI	18
R9007	Sprocket Kit; Simplex; ANSI	18
R9028	Spacer Stainless Steel Yoke	17
R9029	Seal; Hub Inner	24
R9030	Bearing; Hub Inner	24
R9030	Bearing; Hub Outer	24
R9032	Washer; Hub	24
R9033	Nut; Stub	24
R9034	Pin; Cotter, Stub	24
R9035	Cap; Hub	24
R9036	Nut; Wheel, Hub	24
R9037	Hub; Wheel Complete	24

Options

E7045	Light 2 Off LED	25
E7067	Switch; Light	25
R5124	Harness; Wire	25
R5255	Post; LED Lights	25
R5126	Bracket; Switch; for Light Kit	25
R5256	LED Light Kit; Complete	25
R8029	Brush, Nylon 1000mm x 100mm	